

Reflective Object Sensor

OPB703 through OPB705, OPB703WZ through OPB705WZ, OPB701Wz through OPB70HWZ



Features:

- Phototransistor output
- High sensitivity
- Low-cost plastic housing
- Available with lenses for dust protection and ambient light filtration
- Focused for maximum sensitivity

Description:

The **OPB703**, **OPB704** and **OPB705** consist of an Infrared (890nm) Light Emitting Diode (LED) and a NPN silicon Phototransistor, mounted side-by-side on converging optical axes in a black plastic housing and are designed for PCBoard mounting. The **OPB703WZ**, **OPB704WZ**, **OPB705WZ** and **OPB70BWZ** are designed for remote mounting utilizing interconnect wires of UL approved 26 AWG, 24" (61.0cm) minimum length, stripped and tinned.

The **OPB70AWZ** consists of an Infrared (890nm) Light Emitting Diode (LED) and a NPN silicon Photodarlington, mounted side-by-side on converging optical axes in a black plastic housing and is designed for remote mounting utilizing interconnect wires of UL approved 26 AWG, 24" (61.0cm) minimum length, stripped and tinned.

The **OPB70CWZ through OPB70FWZ** consist of a Visible (Red 640nm) Light Emitting Diode (LED) and a NPN silicon Phototransistor or Rbe Phototransistor, mounted side-by-side on converging optical axes in a black plastic housing and are designed for remote mounting utilizing interconnect wires of UL approved 26 AWG, 24" (61.0cm) minimum length, stripped and tinned.

Various lens options are available: No lens for the (**OPB703**, **OPB703WZ**), blue window for dust protection for the (**OPB704**, **OPB704WZ**, **OPB70BWZ**, **OPB70HWZ**) and aperture lens for improved resolution for the (**OPB705**, **OPB705WZ**, **OPB70AWZ**, **OPB70CWZ**, **OPB70DWZ**). The **OPB704G** and **OPB704GWZ** offers excellent protection for dirty environments.

The phototransistor responds to illumination from the emitter when a reflective object passes within the field of view centered typically at 0.15" (3.8 mm).

Custom electrical, wire, cabling and connectors are available. Contact your local representative or OPTEK for more information.

Applications:

- Non-contact reflective object sensor
- Assembly line automation
- Machine automation
- Machine safety
- End of travel sensor
- Door sensor
- Mark Detection
- Office Equipment



| Ordering Information | | | | | | |
|----------------------|----------------|--------------|-------------------|-------------------|-------------|-------------------|
| Part | LED Peak | Detector | Optical Cover | Lead or Wire | | |
| OPB703 | 890 nm | Transistor | None | 0.160" Leads | | |
| OPB703WZ | | | | 24" / 26 AWG Wire | | |
| OPB704 | | | Blue Window | 0.160" Leads | | |
| OPB704WZ | | | | 24" / 26 AWG Wire | | |
| OPB70HWZ | | | | 24" / 26 AWG Wire | | |
| OPB704G | | | | 0.160" Leads | | |
| OPB704GWZ | | | 24" / 26 AWG Wire | | | |
| OPB705 | | | 640 nm | Darlington | Aperture | 0.160" Leads |
| OPB705WZ | | | | | | 24" / 26 AWG Wire |
| OPB70AWZ | | | | Rbe Transistor | Blue Window | |
| OPB70BWZ | | | | | | |
| OPB70CWZ | | | | Rbe Transistor | Aperture | |
| OPB70DWZ | | | | | | |
| OPB70EWZ | Rbe Transistor | Clear Window | | | | |
| OPB70FWZ | | | | | | |
| | | Transistor | | | | |

General Note
TT Electronics reserves the right to make changes in product specification without notice or liability. All information is subject to TT Electronics' own data and is considered accurate at time of going to print.

OPTEK Technology, Inc.
1645 Wallace Drive, Carrollton, TX 75006 | Ph: +1 972 323 2200
www.optekinc.com | www.ttelectronics.com

Reflective Object Sensor



OPB703 through OPB705, OPB&03WZ through OPB705WZ, OPB701Wz through OPB70HWZ

OPB703, OPB704, OPB705

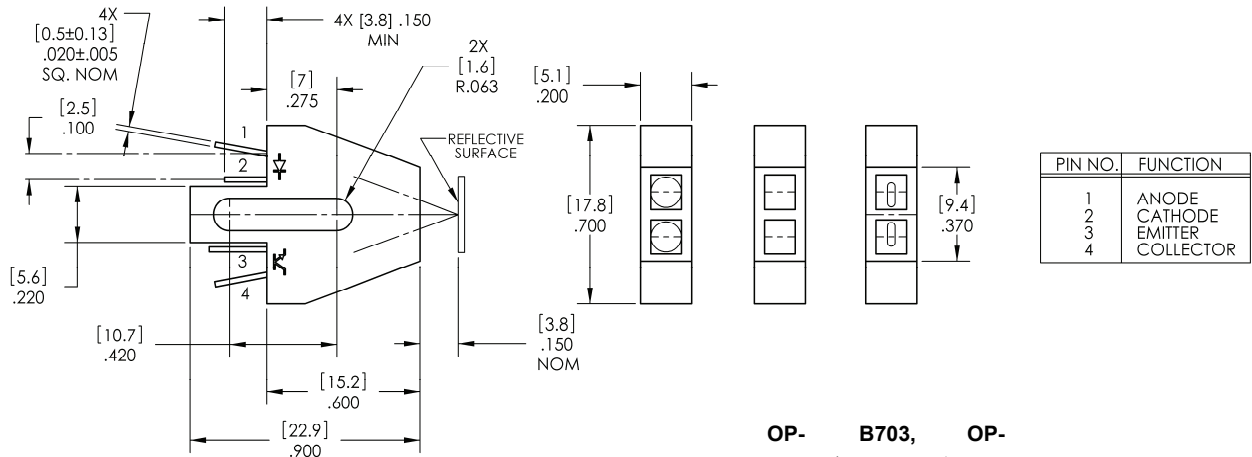

DIMENSIONS ARE IN INCHES [MM]
 TOLERANCES ARE ± .010 UNLESS OTHERWISE SPECIFIED.

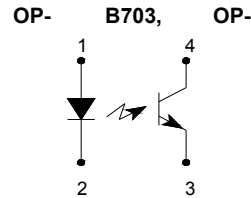

OPB703WZ, OPB704WZ, OPB705WZ, OPB70AWZ, OPB70BWZ, OPB70CWZ, OPB70DWZ

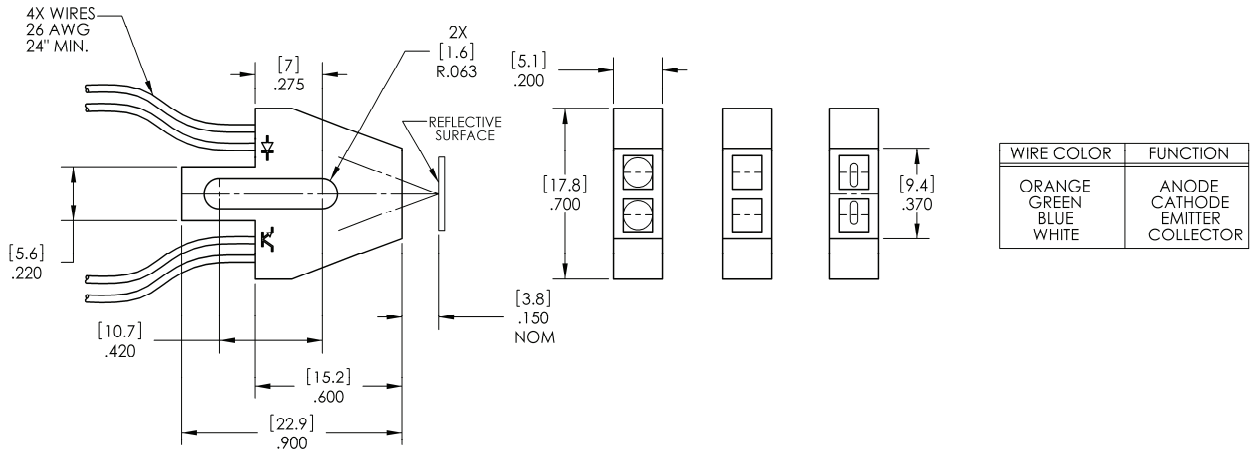

DIMENSIONS ARE IN INCHES [MM]
 TOLERANCES ARE ± .010 UNLESS OTHERWISE SPECIFIED.

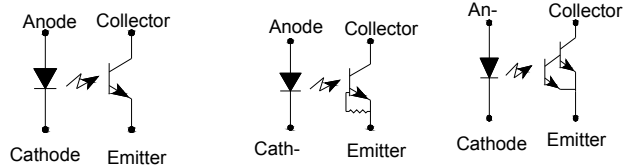

General Note
 TT Electronics reserves the right to make changes in product specification without notice or liability. All information is subject to TT Electronics' own data and is considered accurate at time of going to print.

OPTEK Technology, Inc.
 1645 Wallace Drive, Carrollton, TX 75006 | Ph: +1 972 323 2200
 www.optekinc.com | www.ttelectronics.com

Reflective Object Sensor

OPB703 through OPB705, OPB&03WZ
through OPB705WZ, OPB701Wz through
OPB70HWZ



OPB704G

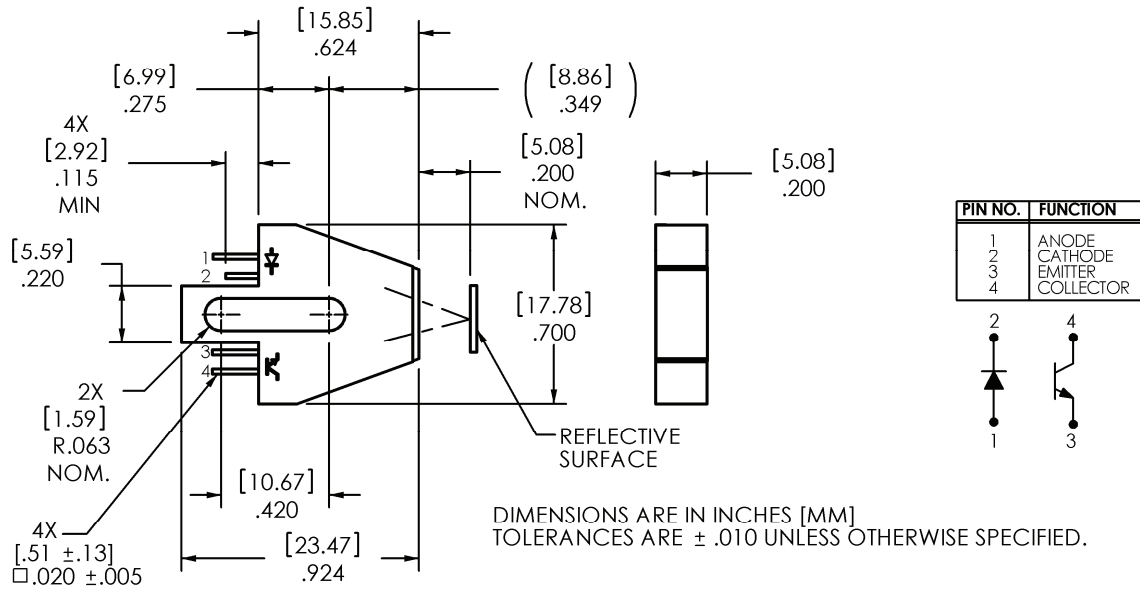

OPB704GWZ

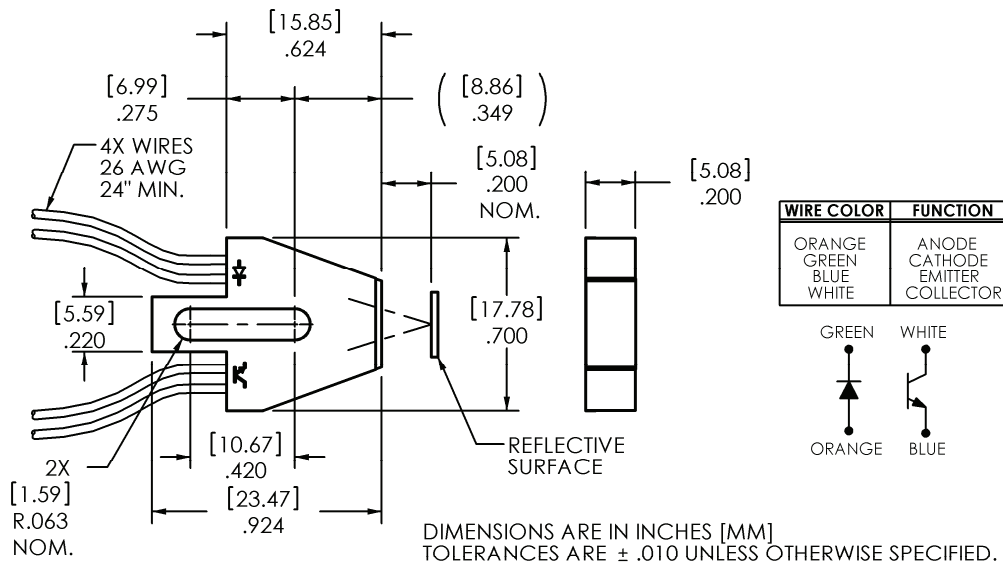

General Note
TT Electronics reserves the right to make changes in product specification without notice or liability. All information is subject to TT Electronics' own data and is considered accurate at time of going to print.

OPTEK Technology, Inc.
1645 Wallace Drive, Carrollton, TX 75006 | Ph: +1 972 323 2200
www.optekinc.com | www.ttelectronics.com

Reflective Object Sensor

OPB703 through OPB705, OPB&03WZ
through OPB705WZ, OPB701Wz through
OPB70HWZ



| Absolute Maximum Ratings (T _A =25°C unless otherwise noted) | |
|--|-----------------------|
| Storage Temperature Range | -40°C to +80° C |
| Lead Soldering Temperature [1/16 inch (1.6 mm) from the case for 5 sec. with soldering iron] | 240° C ⁽¹⁾ |
| Input Diode | |
| Forward DC Current | 40 mA |
| Reverse DC Voltage | 2 V |
| Power Dissipation | 100 mW ⁽²⁾ |
| Output Photodetector | |
| Collector-Emitter Voltage Phototransistor | 30 V |
| Photodarlington | 15 V |
| Emitter-Collector Voltage | 5 V |
| Collector DC Current | 25 mA |
| Power Dissipation | 100 mW ⁽²⁾ |

Notes:

- (1) RMA flux is recommended. Duration can be extended to 10 seconds maximum when flow soldering.
- (2) For OPB703WZ, OPB704WZ, OPB705WZ, OPB70BWZ, OPB704G, OPB704GWZ and OPB70HWZ derate linearly 1.82 mW/° C above 25° C.

Reflective Object Sensor

OPB703 through OPB705, OPB703WZ through OPB705WZ, OPB701Wz through OPB70HWZ



Electrical Characteristics ($T_A = 25^\circ\text{C}$ unless otherwise noted)
(OPB703, OPB703WZ, OPB704, OPB704WZ, OPB705, OPB705WZ, OPB704G, OPB704GWZ, OPB70HWZ)

| SYMBOL | PARAMETER | MIN | TYP | MAX | UNITS | TEST CONDITIONS |
|---|-------------------------------------|------|-----|-----|---------------|--|
| Input Diode (See OP265 for additional information — for reference only) | | | | | | |
| V_F | Forward Voltage | - | - | 1.7 | V | $I_F = 40\text{mA}$ |
| I_R | Reverse Current | - | - | 100 | μA | $V_R = 2\text{V}$ |
| Output Phototransistor (See OP505 for additional information — for reference only) | | | | | | |
| $V_{(BR)CEO}$ | Collector-Emitter Breakdown Voltage | 30 | - | - | V | $I_{CE} = 100\ \mu\text{A}$ |
| $V_{(BR)ECO}$ | Emitter-Collector Breakdown Voltage | 5 | - | - | V | $I_{EC} = 100\ \mu\text{A}$ |
| I_{CEO} | Collector Dark Current | - | - | 250 | nA | $V_{CE} = 10\text{V}, I_F = 0, E_E = 0$ |
| Coupled | | | | | | |
| $I_{C(ON)}$ | On-State Collector Current | | | | | |
| | OPB70HWZ | 0.60 | - | 3.5 | mA | $V_{CE} = 5\text{V}, I_F = 40\text{mA}, d = 0.15''^{(4)(6)}$ |
| | OPB703, OPB703WZ | 0.30 | - | 2.5 | | |
| OPB704, OPB704WZ | 0.20 | - | 2.5 | | | |
| | OPB704G, OPB704GWZ | 0.50 | - | 6.0 | | $V_{CE} = 5\text{V}, I_F = 40\text{mA}, d = 0.20''^{(4)(6)}$ |
| I_{CX} | Crosstalk | | | | μA | $V_{CE} = 5\text{V}, I_F = 40\text{mA}^{(5)}$ |
| | OPB703, OPB703WZ | - | - | 20 | | |
| | OPB704, OPB704WZ, OPB70HWZ | - | - | 20 | | |

Notes:

- (1) RMA flux is recommended. Duration can be extended to 10 seconds maximum when flow soldering.
- (2) For OPB703, OPB704 and OPB705, derate linearly 1.67 mW/ $^\circ\text{C}$ above 25 $^\circ\text{C}$.
- (3) For OPB703WZ, OPB704WZ, OPB705WZ, OPB70BWZ, OPB704G, OPB704GWZ, OPB70HWZ, OPB70AWZ, OPB70CWZ, OPB70DWZ, OPB70EWZ, and OPB70FWZ derate linearly 1.82 mW/ $^\circ\text{C}$ above 25 $^\circ\text{C}$.
- (4) The distance from the assembly face to the reflective surface is d.
- (5) Crosstalk (I_{CX}) is the collector current measured with the indicated current in the input diode and with no reflecting surface.
- (6) Measured using Eastman Kodak neutral white test card with 90% diffuse reflectance as a reflecting surface. Reference: Eastman Kodak, Catalog # E 152 7795.
- (7) All parameters tested using pulse techniques.

Reflective Object Sensor

OPB703 through OPB705, OPB&03WZ
through OPB705WZ, OPB701Wz through
OPB70HWZ



Electrical Characteristics ($T_A = 25^\circ\text{C}$ unless otherwise noted) (OPB70AWZ)

| SYMBOL | PARAMETER | MIN | TYP | MAX | UNITS | TEST CONDITIONS |
|---|-------------------------------------|-----|-----|------|---------------|---|
| Input Diode (See OP265 for additional information — for reference only) | | | | | | |
| V_F | Forward Voltage | - | - | 1.7 | V | $I_F = 40\text{mA}$ |
| I_R | Reverse Current | - | - | 100 | μA | $V_R = 2\text{V}$ |
| Output PhotoDarlington (See OP535 for additional information — for reference only) | | | | | | |
| $V_{(BR)CEO}$ | Collector-Emitter Breakdown Voltage | 15 | - | - | V | $I_{CE} = 1.0\text{mA}$, $E_E = 0$ |
| $V_{(BR)ECO}$ | Emitter-Collector Breakdown Voltage | 5 | - | - | V | $I_{EC} = 100\mu\text{A}$, $E_E = 0$ |
| I_{CEO} | Collector Dark Current | - | - | 250 | nA | $V_{CE} = 10\text{V}$, $I_F = 0$, $E_E = 0$ |
| Coupled | | | | | | |
| $I_{C(ON)}$ | On-State Collector Current | 5.0 | - | 26.0 | mA | $V_{CE} = 5\text{V}$, $I_F = 40\text{mA}$, $d = 0.15''$ ⁽¹⁾⁽³⁾ |
| $V_{(SAT)}$ | Saturation Voltage | - | - | 1.15 | V | $I_C = 400\mu\text{A}$, $I_F = 40\text{mA}$, $d = 0.15''$ ⁽¹⁾⁽³⁾ |
| I_{CX} | Crosstalk | - | - | 25 | μA | $V_{CE} = 5\text{V}$, $I_F = 40\text{mA}$ ⁽²⁾ |

Notes:

- (1) The distance from the assembly face to the reflective surface is d .
- (2) Crosstalk (I_{CX}) is the collector current measured with the indicated current in the input diode and with no reflecting surface.
- (3) Measured using Eastman Kodak neutral white test card with 90% diffuse reflectance as a reflecting surface. Reference: Eastman Kodak, Catalog # E 152 7795.

Reflective Object Sensor

OPB703 through OPB705, OPB&03WZ
through OPB705WZ, OPB701Wz through
OPB70HWZ



Electrical Characteristics ($T_A = 25^\circ\text{C}$ unless otherwise noted) (OPB70BWZ)

| SYMBOL | PARAMETER | MIN | TYP | MAX | UNITS | TEST CONDITIONS |
|---|--|------|-----|-----|---------------|--|
| Input Diode (See OP265 for additional information — for reference only) | | | | | | |
| V_F | Forward Voltage | - | - | 1.7 | V | $I_F = 40\text{mA}$ |
| I_R | Reverse Current | - | - | 100 | μA | $V_R = 2\text{V}$ |
| Output Phototransistor (See OP705 for additional information — for reference only) | | | | | | |
| $V_{(BR)CEO}$ | Collector-Emitter Breakdown Voltage | 30 | - | - | V | $I_{CE} = 100\ \mu\text{A}$ |
| $V_{(BR)ECO}$ | Emitter-Collector Breakdown Voltage | 0.4 | - | - | V | $I_{EC} = 100\ \mu\text{A}$ |
| I_{CEO} | Collector Dark Current | - | - | 100 | nA | $V_{CE} = 10\text{V}, I_F = 0, E_E = 0$ |
| Coupled | | | | | | |
| $I_{C(ON)}$ | On-State Collector Current OPB70BWZ | 0.50 | - | 3.0 | mA | $V_{CE} = 5\text{V}, I_F = 40\text{mA}, d = 0.15''^{(1)(3)}$ |
| I_{CX} | Crosstalk OPB70BWZ | - | - | 5 | μA | $V_{CE} = 5\text{V}, I_F = 40\text{mA}^{(2)}$ |

Notes:

- (1) The distance from the assembly face to the reflective surface is d .
- (2) Crosstalk (I_{CX}) is the collector current measured with the indicated current in the input diode and with no reflecting surface.
- (3) Measured using Eastman Kodak neutral white test card with 90% diffuse reflectance as a reflecting surface. Reference: Eastman Kodak, Catalog # E 152 7795.

Reflective Object Sensor

OPB703 through OPB705, OPB&03WZ
through OPB705WZ, OPB701Wz through
OPB70HWZ



Electrical Characteristics ($T_A = 25^\circ\text{C}$ unless otherwise noted) (OPB70CWZ and OPB70EWZ)

| SYMBOL | PARAMETER | MIN | TYP | MAX | UNITS | TEST CONDITIONS |
|---|-------------------------------------|-----|-----|-----|---------------|---|
| Input Diode (See OVLAS6CB8 for additional information — for reference only) | | | | | | |
| V_F | Forward Voltage | - | - | 2.6 | V | $I_F = 40\text{mA}$ |
| I_R | Reverse Current | - | - | 100 | μA | $V_R = 2\text{V}$ |
| Output Phototransistor (See OP505 for additional information — for reference only) | | | | | | |
| $V_{(BR)CEO}$ | Collector-Emitter Breakdown Voltage | 30 | - | - | V | $I_{CE} = 100\mu\text{A}, I_F = 0, E_E = 0$ |
| $V_{(BR)ECO}$ | Emitter-Collector Breakdown Voltage | 0.4 | - | - | V | $I_{EC} = 100\mu\text{A}, I_F = 0, E_E = 0$ |
| I_{CEO} | Collector Dark Current | - | - | 100 | nA | $V_{CE} = 10\text{V}, I_F = 0, E_E = 0$ |

Coupled

| | | | | | | | |
|-------------|----------------------------|----------|-----|-----|---------------|--|--|
| $I_{C(ON)}$ | On-State Collector Current | OPB70CWZ | .10 | - | 1.0 | mA | $V_{CE} = 5\text{V}, I_F = 40\text{mA}, d = 0.15''^{(2)(3)}$ |
| | | OPB70EWZ | .25 | - | 2.5 | | |
| $V_{(SAT)}$ | Saturation Voltage | - | - | 0.4 | V | $I_C = 100\mu\text{A}, I_F = 40\text{mA}, d = 0.15''^{(1)(3)}$ | |
| I_{CX} | Crosstalk | - | - | 2 | μA | $V_{CE} = 5\text{V}, I_F = 40\text{mA}^{(2)}$ | |

Notes:

- (1) The distance from the assembly face to the reflective surface is d .
- (2) Crosstalk (I_{CX}) is the collector current measured with the indicated current in the input diode and with no reflecting surface.
- (3) Measured using Eastman Kodak neutral white test card with 90% diffuse reflectance as a reflecting surface. Reference: Eastman Kodak, Catalog # E 152 7795.

Reflective Object Sensor

OPB703 through OPB705, OPB&03WZ
through OPB705WZ, OPB701Wz through
OPB70HWZ



Electrical Characteristics ($T_A = 25^\circ\text{C}$ unless otherwise noted) (OPB70DWZ and OPB70FWZ)

| SYMBOL | PARAMETER | MIN | TYP | MAX | UNITS | TEST CONDITIONS |
|---|-------------------------------------|-----|-----|-----|---------------|---|
| Input Diode (See OVLAS6CB8 for additional information — for reference only) | | | | | | |
| V_F | Forward Voltage | - | - | 2.6 | V | $I_F = 40\text{mA}$ |
| I_R | Reverse Current | - | - | 100 | μA | $V_R = 2\text{V}$ |
| Output Phototransistor (See OP505 for additional information — for reference only) | | | | | | |
| $V_{(BR)CEO}$ | Collector-Emitter Breakdown Voltage | 30 | - | - | V | $I_{CE} = 100\mu\text{A}, I_F = 0, E_E = 0$ |
| $V_{(BR)ECO}$ | Emitter-Collector Breakdown Voltage | 5.0 | - | - | V | $I_{EC} = 100\mu\text{A}, I_F = 0, E_E = 0$ |
| I_{CEO} | Collector Dark Current | - | - | 250 | nA | $V_{CE} = 10\text{V}, I_F = 0, E_E = 0$ |

Coupled

| | | | | | | | |
|-------------|----------------------------|----------|-----|-----|---------------|--|--|
| $I_{C(ON)}$ | On-State Collector Current | OPB70DWZ | .10 | - | 1.5 | mA | $V_{CE} = 5\text{V}, I_F = 40\text{mA}, d = 0.15''^{(1)(3)}$ |
| | | OPB70FWZ | .25 | - | 3.5 | | |
| $V_{(SAT)}$ | Saturation Voltage | - | - | 0.4 | V | $I_{C(ON)} = 100\mu\text{A}, I_F = 40\text{mA}, d = 0.15''^{(1)(3)}$ | |
| I_{CX} | Crosstalk | - | - | 5.0 | μA | $V_{CE} = 5\text{V}, I_F = 40\text{mA}^{(2)}$ | |

Notes:

- (1) The distance from the assembly face to the reflective surface is d .
- (2) Crosstalk (I_{CX}) is the collector current measured with the indicated current in the input diode and with no reflecting surface.
- (3) Measured using Eastman Kodak neutral white test card with 90% diffuse reflectance as a reflecting surface. Reference: Eastman Kodak, Catalog # E 152 7795.

Reflective Object Sensor

OPB703 through OPB705, OPB&03WZ through OPB705WZ, OPB701Wz through OPB70HWZ



OPB703 - Output vs Distance

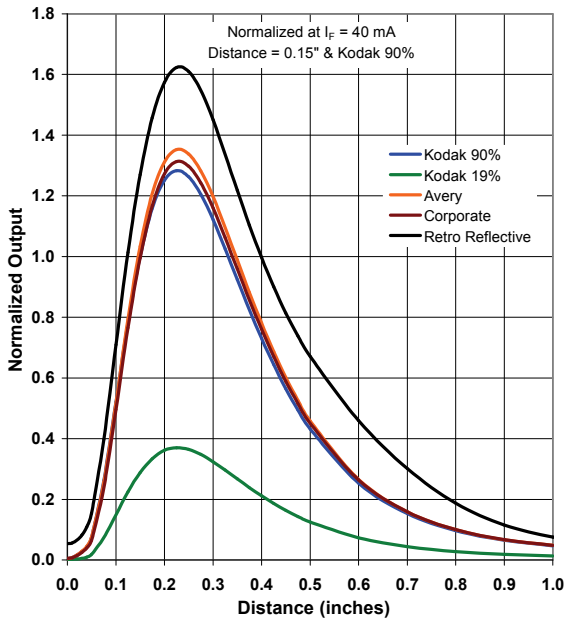

OPB704 - Output vs Distance

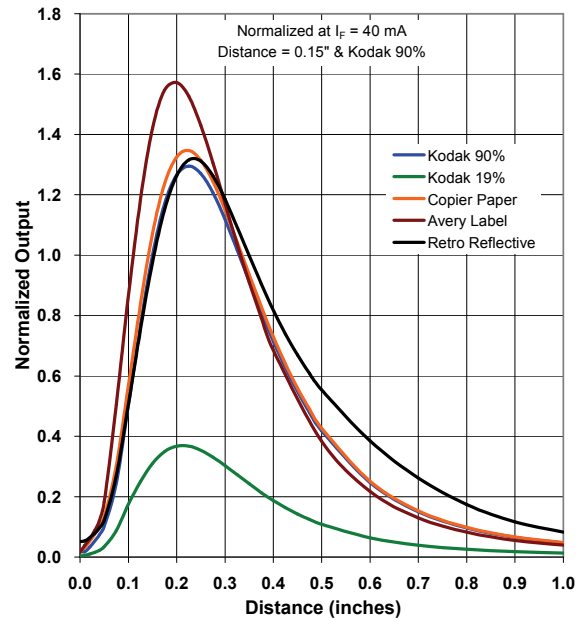

OPB705 - Output vs Distance

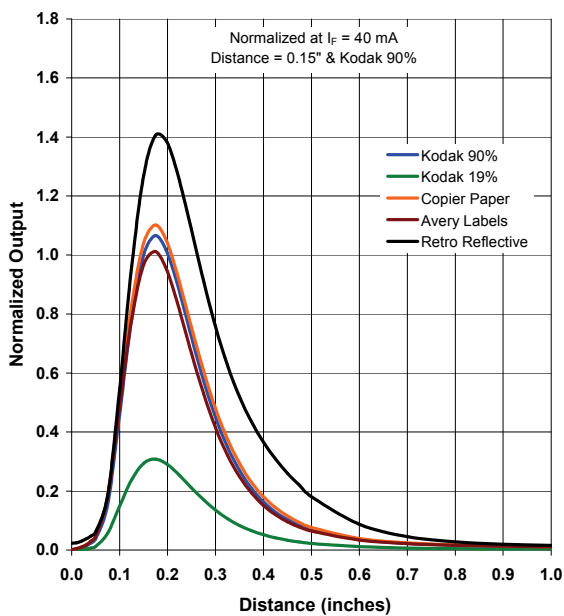

Forward Voltage vs Forward Current vs Temp

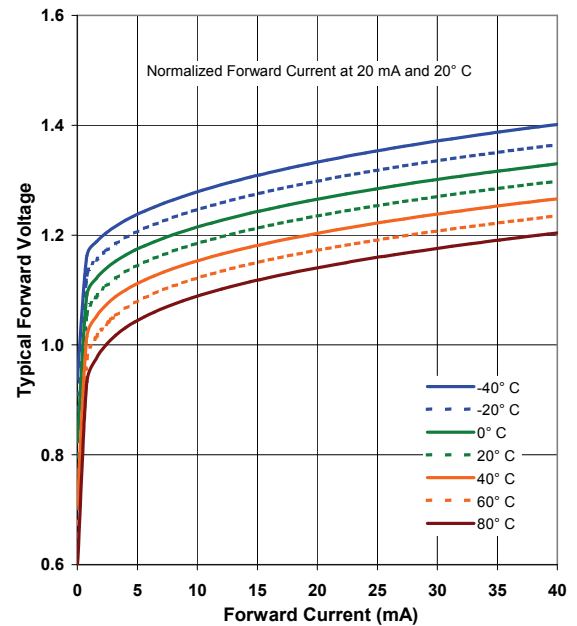

General Note
TT Electronics reserves the right to make changes in product specification without notice or liability. All information is subject to TT Electronics' own data and is considered accurate at time of going to print.

OPTEK Technology, Inc.
1645 Wallace Drive, Carrollton, TX 75006 | Ph: +1 972 323 2200
www.optekinc.com | www.ttelectronics.com

Reflective Object Sensor

OPB703 through OPB705, OPB&03WZ through OPB705WZ, OPB701Wz through OPB70HWZ

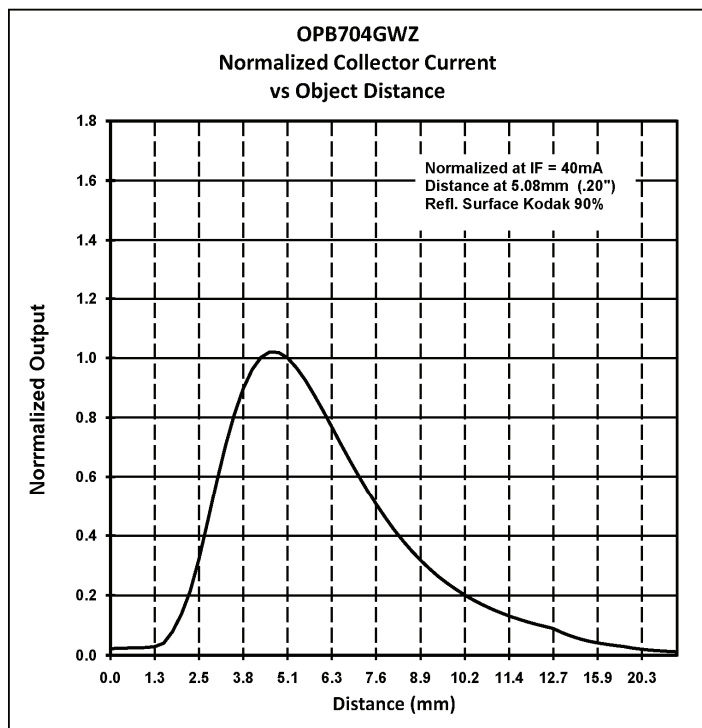

General Note
TT Electronics reserves the right to make changes in product specification without notice or liability. All information is subject to TT Electronics' own data and is considered accurate at time of going to print.

OPTEK Technology, Inc.
1645 Wallace Drive, Carrollton, TX 75006 | Ph: +1 972 323 2200
www.optekinc.com | www.ttelectronics.com