

FK BEARINGS

Precision Rod Ends & Spherical Bearings

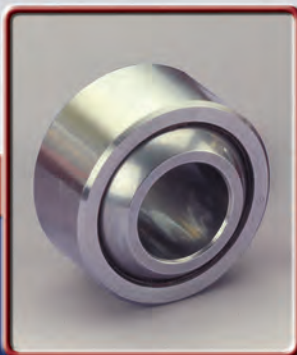

Rod Ends



Bearings



PTFE Liners



Options

For additional products visit:
www.fkrodends.com

F.K. BEARINGS came onto the scene quietly over 24 years ago. They did not make a huge splash, but quickly won the customers over with fair pricing, and plenty of inventory. While the industrial market struggled to get product from the old stand-bys, the racing market embraced a supplier that would maintain inventory throughout the limited season. Recently, to further assure timely delivery, F.K. Bearings set up two regional warehouses. Filled to the brim with inventory, these warehouses can offer localized service for emergency orders.

Over the years the F.K. Bearings product line has grown to encompass many different industries. From the wilds of Baja Mexico, to the “good old boys” of NASCAR...from mowers to care for your lawn, to fitness equipment to groom your body, you'll find F.K. Rod Ends!

In your hands is our latest offering in an evolving program designed to supply rod end products to users everywhere! You will find rod ends and spherical bearings made from mild steel, chromemoly/alloy steel, aluminum and stainless. Special care is taken during every step of the manufacturing process to insure you the highest quality products.

With almost 10,000 combinations of rod ends and spherical bearings available, you will appreciate the effort that goes into filling each order. Within our state-of-the-art facility, we carefully craft our products, so we are able to say, “Yes, it's in stock” when you call.

PTFE LINERS

F.K. Bearings offers self-lubricating PTFE liners on nearly all of our rod ends and spherical bearings. The PTFE liner is chemically bonded to the inner diameter of the race. This liner offers a very high load-carrying capacity and has greatly increased dynamic and wear characteristics. The operating temperatures of our liners range from -65° to 325° F.

CUSTOMER SERVICE

All F.K.'s sales personnel have extensive product training to assist you in the selection of the proper bearing for your application. District sales representatives for F.K. work very closely with inside sales and engineering, to ensure you excellent service and on-time delivery.

Thank you for your interest in F.K. Rod Ends.



CONTENTS

Commercial / Industrial Rod Ends

CM / CF	2-piece, metal to metal	4
ECM / ECF	2-piece, Import, metal to metal	5
CM-T / CF-T	2-piece, PTFE lined, self lubricated	6
SCM-T / SCF-T	2-piece, stainless steel with PTFE liner	7
CM-M / CF-M	2-piece, metric, metal to metal	8
SCM-MT / SCF-MT	2-piece, metric, stainless steel with PTFE liner	9
CM-Y / CF-Y	2-piece, metal to metal with studs	10
CM SPECIAL	2-piece, metal to metal, special bore sizes	11
CMX / CMX-T	2-piece, metal to metal, heat treated, alloy steel	20

Precision Series Rod Ends

NJM / NJF	3-piece, plastic race	12
M-SB / F-SB	3-piece, sintered bronze race	13
JM / JML	3-piece, male, alloy steel race	14
JF / JFL	3-piece, female, alloy steel race	15
JMX / JMXL	3-piece, male, high strength alloy	16
JFX / JFXL	3-piece, female, high strength alloy	17
KMX / KMXL	3-piece, male, high strength alloy steel with injected nylon race	21
RJM / RJF	3-piece, precision, decorative chrome plated	22
RJMX-T	3-piece, male, high strength alloy, chrome or bright nickel plated, self lubricating	23
SJM-T	3-piece, male, stainless steel - wear resistant, self lubricating	24
SJF-T / SJFL-T	3-piece, female, stainless steel - wear resistant, self lubricating	25
HJMX-T / HJMXL-T	3-piece, male, high strength alloy steel, high misalignment, self lubricating	27
PMX-T / PMXL-T	3-piece, male, Performance Racing, stainless steel insert, self lubricating	28
ALJM / ALJML	3-piece, male aluminum body	30
ALJF / ALRSML	3-piece, female aluminum body	31

Extra Strength-Heavy Duty Shank

RSM / RSM-T	3-piece, low carbon steel, PTFE liners available	18
RSMX / RSMX-T	3-piece, alloy steel, PTFE liners available	19
RRSMX-T	3-piece, alloy steel, chrome or bright nickel plated, self lubricating	23
SRSM-T	3-piece, male, stainless steel, self lubricating	24
HRSMX-T	3-piece, high strength alloy steel, high misalignment, self lubricating	26
EMX	3-piece, alloy steel, PTFE liners available	29
ALRSM	3-piece, aluminum body	32

Spherical Bearings

HIN-T	High misalignment, alloy steel, heat treated, self lubricating	26
COM / COMH	Commercial series, low carbon steel	34
FKS / FKS-T	Precision narrow series, alloy steel, heat treated	35
FKSSX-T / FKSSX-TV / PFKSSX-T	Precision narrow series, stainless steel, self lubricating	36
WSSX-T / WSSX-TV	Wide series, stainless steel, self lubricating	37
IN-P	Plastic race series	38
K SERIES	Special purpose series	39
GEZ-ES	Inch - Fractured race series	40
GE-ES	Metric - Fractured race series	41

Special Products

ADJUSTER LADDER	3/4" right to left hand turnbuckle	33
B	Ball Joints	33
HB	High misalignment bushings	42
CTR	Center finders for rod end adjustment lengths	42
AJNR / AJNL	Inch Aluminum jam nuts	43
SJNR / SJNL	Inch Steel jam nuts	43
SJNR-M / SJNL-M	Metric Steel jam nuts	43
STUDS	Studded rod ends	43
RD	Solid rod ends	44
CV	Clevis	44
WELDABLE TUBE ENDS	Threaded tube ends for rod end bearings	45
RERS SERIES SEALS	Molded-rubber boots	46
WS SERIES SEALS	WS Series seals	47

Additional Information

Engineering Data	48
Interchange Table	49

CM / CF

2-PIECE, METAL TO METAL

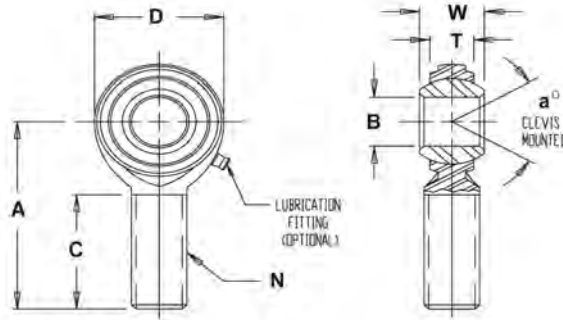

MATERIALS

BALL	BODY
52100 STEEL	LOW CARBON STEEL
Rc 56 MIN. HARDNESS	ZINC PLATED
HARD CHROME PLATED	CHROMATE TREATED

MALE ROD ENDS		B DIA.	D DIA.	W WIDTH	T WIDTH	BALL DIA.	A LGTH	N THD.	C LGTH	a° MIS. ANGLE	ULT. STATIC RADIAL LOAD (lbs.)	APPROX. WEIGHT (lbs.)
RIGHT HAND PART NO.	LEFT HAND PART NO.	+ .0025 - .0005	+ .010 - .010	+ .005 - .005	REF.	REF.	+ .015 - .015	UNF 3A	+ .062 - .031	REF.		
CM3*	CML3*	.1900	.625	.312	.234	.437	1.250	10-32	.750	20	1,210	.03
CM4*	CML4*	.2500	.750	.375	.250	.500	1.562	1/4-28	1.000	27	2,225	.04
CM5*	CML5*	.3125	.875	.437	.312	.625	1.875	5/16-24	1.250	22	3,600	.07
CM6	CML6	.3750	1.000	.500	.359	.719	1.938	3/8-24	1.250	22	5,100	.11
CM7	CML7	.4375	1.125	.562	.406	.812	2.125	7/16-20	1.375	21	6,402	.15
CM8	CML8	.5000	1.312	.625	.453	.937	2.438	1/2-20	1.500	20	8,386	.24
CM10	CML10	.6250	1.500	.750	.484	1.125	2.625	5/8-18	1.625	26	9,813	.36
CM12	CML12	.7500	1.750	.875	.593	1.312	2.875	3/4-16	1.750	24	14,290	.57

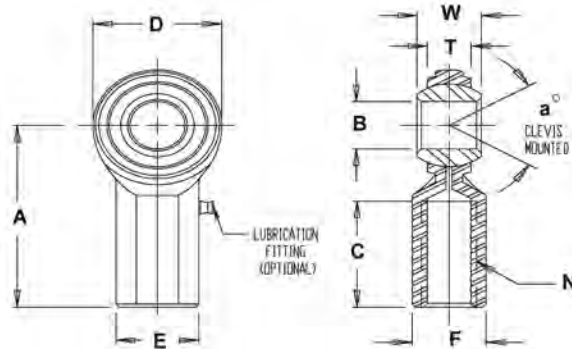

*GREASE FITTINGS ARE NOT SUPPLIED ON THESE SIZES. MALE ROD END LOAD RATINGS BASED ON NO LUBRICATING FITTING. FOR LOAD RATINGS WITH LUBRICATOR, PLEASE CONTACT THE F.K. ENGINEERING DEPARTMENT.

MATERIALS

BALL	BODY
52100 STEEL	LOW CARBON STEEL
Rc 56 MIN. HARDNESS	ZINC PLATED
HARD CHROME PLATED	CHROMATE TREATED

FEMALE ROD ENDS		B DIA.	D DIA.	W WIDTH	T WIDTH	BALL DIA.	A LGTH	N THD.	C LGTH	E DIA.	F FLAT	a° MIS. ANGLE	ULT. STATIC RADIAL LOAD (lbs.)	APPROX. WEIGHT (lbs.)
RIGHT HAND PART NO.	LEFT HAND PART NO.	+ .0025 - .0005	+ .010 - .010	+ .005 - .005	REF.	REF.	+ .015 - .015	UNF 2B	+ .062 - .031	+ .010 - .010	+ .010 - .010	REF.		
CF3*	CFL3*	.1900	.625	.312	.234	.437	1.062	10-32	.500	.406	.312	20	2,100	.04
CF4-3	N / A	.2500	.750	.375	.250	.500	1.312	10-32	.687	.468	.375	27	3,250	.05
CF4	CFL4	.2500	.750	.375	.250	.500	1.312	1/4-28	.687	.468	.375	27	3,250	.05
CF5	CFL5	.3125	.875	.437	.312	.625	1.375	5/16-24	.687	.500	.437	22	3,934	.08
CF6	CFL6	.3750	1.000	.500	.359	.719	1.625	3/8-24	.812	.687	.562	22	5,100	.13
CF7	CFL7	.4375	1.125	.562	.406	.812	1.812	7/16-20	.937	.750	.625	21	6,420	.18
CF8	CFL8	.5000	1.312	.625	.453	.937	2.125	1/2-20	1.062	.875	.750	20	9,100	.29
CF10	CFL10	.6250	1.500	.750	.484	1.125	2.500	5/8-18	1.375	1.000	.875	26	9,800	.43
CF12	CFL12	.7500	1.750	.875	.593	1.312	2.875	3/4-16	1.562	1.125	1.000	24	14,250	.65

NOTES: FOR GREASE FITTINGS ADD "Z" TO SUFFIX. EXAMPLE: CF6Z

ECM / ECF *IMPORT*

2-PIECE, METAL TO METAL

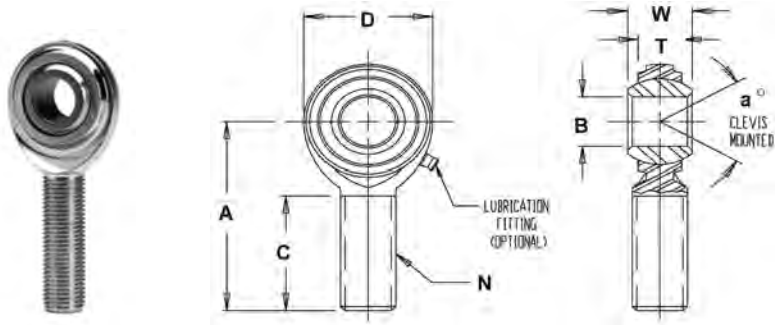

MATERIALS

BALL	BODY
ALLOY STEEL	LOW CARBON STEEL
HEAT TREATED	ZINC PLATED
HARD CHROME PLATED	CHROMATE TREATED

MALE ROD ENDS		B DIA.	D DIA.	W WIDTH	T WIDTH	BALL DIA.	A LGTH	N THD.	C LGTH	a° MIS. ANGLE	ULT. STATIC RADIAL LOAD (lbs.)	APPROX. WEIGHT (lbs.)
RIGHT HAND PART NO.	LEFT HAND PART NO.	+.0025 -.0005	+.010 -.010	+.005 -.005	REF.	REF.	+.015 -.015	UNF 3A	+.062 -.031	REF.		
ECM3*	ECML3*	.1900	.625	.312	.234	.437	1.250	10-32	.750	20	1,210	.03
ECM4*	ECML4*	.2500	.750	.375	.250	.500	1.562	1/4-28	1.000	27	2,225	.04
ECM5*	ECML5*	.3125	.875	.437	.312	.625	1.875	5/16-24	1.250	22	3,600	.07
ECM6	ECML6	.3750	1.000	.500	.359	.719	1.938	3/8-24	1.250	22	5,100	.11
ECM7	ECML7	.4375	1.125	.562	.406	.812	2.125	7/16-20	1.375	21	6,402	.15
ECM8	ECML8	.5000	1.312	.625	.453	.937	2.438	1/2-20	1.500	20	8,386	.24
ECM10	ECML10	.6250	1.500	.750	.484	1.125	2.625	5/8-18	1.625	26	9,813	.36
ECM12	ECML12	.7500	1.750	.875	.593	1.312	2.875	3/4-16	1.750	24	14,290	.57

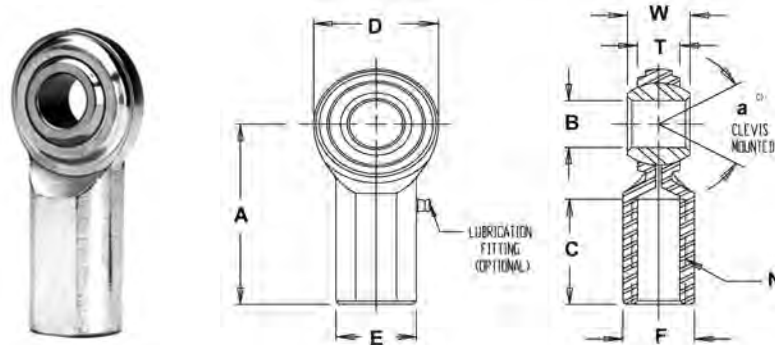

*GREASE FITTINGS ARE NOT SUPPLIED ON THESE SIZES. MALE ROD END LOAD RATINGS BASED ON NO LUBRICATING FITTING. FOR LOAD RATINGS WITH LUBRICATOR, PLEASE CONTACT THE F.K. ENGINEERING DEPARTMENT.

MATERIALS

BALL	BODY
ALLOY STEEL	LOW CARBON STEEL
HEAT TREATED	ZINC PLATED
HARD CHROME PLATED	CHROMATE TREATED

FEMALE ROD ENDS		B DIA.	D DIA.	W WIDTH	T WIDTH	BALL DIA.	A LGTH	N THD.	C LGTH	E DIA.	F FLAT	a° MIS. ANGLE	ULT. STATIC RADIAL LOAD (lbs.)	APPROX. WEIGHT (lbs.)
RIGHT HAND PART NO.	LEFT HAND PART NO.	+.0025 -.0005	+.010 -.010	+.005 -.005	REF.	REF.	+.015 -.015	UNF 2B	+.062 -.031	+.010 -.010	+.010 -.010	REF.		
ECF3*	ECFL3*	.1900	.625	.312	.234	.437	1.062	10-32	.500	.406	.312	20	2,100	.04
ECF4	ECFL4	.2500	.750	.375	.250	.500	1.312	1/4-28	.687	.468	.375	27	3,250	.05
ECF5	ECFL5	.3125	.875	.437	.312	.625	1.375	5/16-24	.687	.500	.437	22	3,934	.08
ECF6	ECFL6	.3750	1.000	.500	.359	.719	1.625	3/8-24	.812	.687	.562	22	5,100	.13
ECF7	ECFL7	.4375	1.125	.562	.406	.812	1.812	7/16-20	.937	.750	.625	21	6,420	.18
ECF8	ECFL8	.5000	1.312	.625	.453	.937	2.125	1/2-20	1.062	.875	.750	20	9,100	.29
ECF10	ECFL10	.6250	1.500	.750	.484	1.125	2.500	5/8-18	1.375	1.000	.875	26	9,800	.43
ECF12	ECFL12	.7500	1.750	.875	.593	1.312	2.875	3/4-16	1.562	1.125	1.000	24	14,250	.65

NOTES: FOR GREASE FITTINGS ADD "Z" TO SUFFIX. EXAMPLE: ECF6Z



CM-T / CF-T

2-PIECE, SELF-LUBRICATING

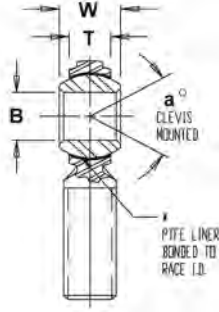
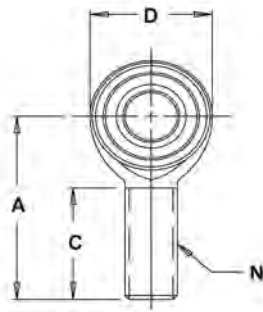

MATERIALS

BALL	BODY
52100 STEEL	LOW CARBON STEEL
Rc 56 MIN. HARDNESS	ZINC PLATED
HARD CHROME PLATED	CHROMATE TREATED
LINER	
*TEFLON FABRIC	

MALE ROD ENDS		B DIA.	D DIA.	W WIDTH	T WIDTH	BALL DIA.	A LGTH	N THD.	C LGTH	a° MIS. ANGLE	ULT. STATIC RADIAL LOAD (lbs.)	APPROX. WEIGHT (lbs.)
RIGHT HAND PART NO.	LEFT HAND PART NO.	+ .0025 - .0005	+ .010 - .010	+ .005 - .005	REF.	REF.	+ .015 - .015	UNF 3A	+ .062 - .031	REF.		
CM3T	CML3T	.1900	.625	.312	.234	.437	1.250	10-32	.750	20	902	.03
CM4T	CML4T	.2500	.750	.375	.250	.500	1.562	1/4-28	1.000	27	1,809	.04
CM5T	CML5T	.3125	.875	.437	.312	.625	1.875	5/16-24	1.250	22	2,984	.07
CM6T	CML6T	.3750	1.000	.500	.359	.719	1.938	3/8-24	1.250	22	4,244	.11
CM7T	CML7T	.4375	1.125	.562	.406	.812	2.125	7/16-20	1.375	21	5,312	.15
CM8T	CML8T	.5000	1.312	.625	.453	.937	2.438	1/2-20	1.500	20	7,211	.24
CM10T	CML10T	.6250	1.500	.750	.484	1.125	2.625	5/8-18	1.625	26	8,403	.36
CM12T	CML12T	.7500	1.750	.875	.593	1.312	2.875	3/4-16	1.750	24	12,321	.57

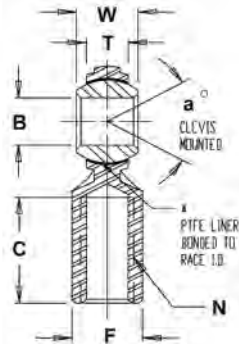
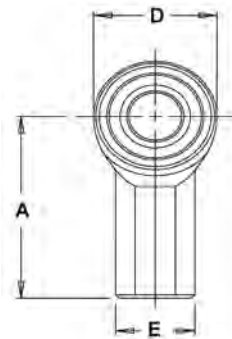

MATERIALS

BALL	BODY
52100 STEEL	LOW CARBON STEEL
Rc 56 MIN. HARDNESS	ZINC PLATED
HARD CHROME PLATED	CHROMATE TREATED
LINER	
*TEFLON FABRIC	

FEMALE ROD ENDS		B DIA.	D DIA.	W WIDTH	T WIDTH	BALL DIA.	A LGTH	N THD.	C LGTH	E DIA.	F FLAT	a° MIS. ANGLE	ULT. STATIC RADIAL LOAD (lbs.)	APPROX. WEIGHT (lbs.)
RIGHT HAND PART NO.	LEFT HAND PART NO.	+ .0025 - .0005	+ .010 - .010	+ .005 - .005	REF.	REF.	+ .015 - .015	UNF 2B	+ .062 - .031	+ .010 - .010	+ .010 - .010	REF.		
CF3T	CFL3T	.1900	.625	.312	.234	.437	1.062	10-32	.500	.406	.312	20	1,637	.04
CF4T	CFL4T	.2500	.750	.375	.250	.500	1.312	1/4-28	.687	.468	.375	27	2,612	.05
CF5T	CFL5T	.3125	.875	.437	.312	.625	1.375	5/16-24	.687	.500	.437	22	3,110	.08
CF6T	CFL6T	.3750	1.000	.500	.359	.719	1.625	3/8-24	.812	.687	.562	22	4,206	.13
CF7T	CFL7T	.4375	1.125	.562	.406	.812	1.812	7/16-20	.937	.750	.625	21	5,384	.18
CF8T	CFL8T	.5000	1.312	.625	.453	.937	2.125	1/2-20	1.062	.875	.750	20	7,826	.29
CF10T	CFL10T	.6250	1.500	.750	.484	1.125	2.500	5/8-18	1.375	1.000	.875	26	8,343	.43
CF12T	CFL12T	.7500	1.750	.875	.593	1.312	2.875	3/4-16	1.562	1.125	1.000	24	12,342	.65

* A TRADE MARK OF E.I. DUPONT DE NEMOURS & CO., INC.

NOTES: FOR STUD ADD "Y" TO SUFFIX. EXAMPLE: CM10TY



SCM-T / SCF-T

2-PIECE, STAINLESS STEEL, SELF-LUBRICATING

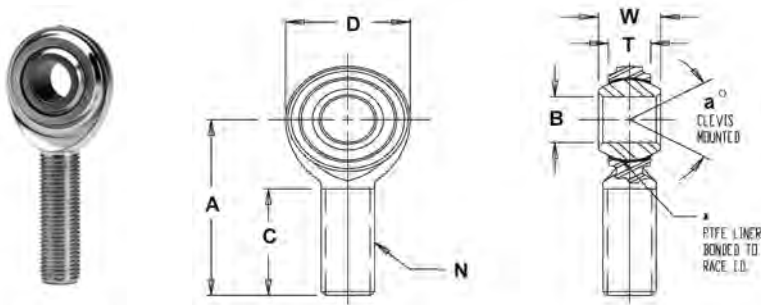

MATERIALS

BALL	BODY
440C STAINLESS STEEL HEAT TREATED	303 STAINLESS STEEL PASSIVATED
LINER	
*TEFLON FABRIC	

MALE ROD ENDS		B DIA.	D DIA.	W WIDTH	T WIDTH	BALL DIA.	A LGTH	N THD.	C LGTH	a° MIS. ANGLE	ULT. STATIC RADIAL LOAD (lbs.)	APPROX. WEIGHT (lbs.)
RIGHT HAND PART NO.	LEFT HAND PART NO.	+.0025 -.0005	+.010 -.010	+.005 -.005	REF.	REF.	+.015 -.015	UNF 3A	+.062 -.031	REF.		
SCM3T	SCML3T	.1900	.625	.312	.234	.437	1.250	10-32	.750	20	912	.03
SCM4T	SCML4T	.2500	.750	.375	.250	.500	1.562	1/4-28	1.000	27	1,370	.04
SCM5T	SCML5T	.3125	.875	.437	.312	.625	1.875	5/16-24	1.250	22	2,050	.07
SCM6T	SCML6T	.3750	1.000	.500	.359	.719	1.938	3/8-24	1.250	22	3,040	.11
SCM7T	SCML7T	.4375	1.125	.562	.406	.812	2.125	7/16-20	1.375	21	3,780	.15
SCM8T	SCML8T	.5000	1.312	.625	.453	.937	2.438	1/2-20	1.500	20	4,700	.24
SCM10T	SCML10T	.6250	1.500	.750	.484	1.125	2.625	5/8-18	1.625	26	5,860	.36
SCM12T	SCML12T	.7500	1.750	.875	.593	1.312	2.875	3/4-16	1.750	24	7,512	.57

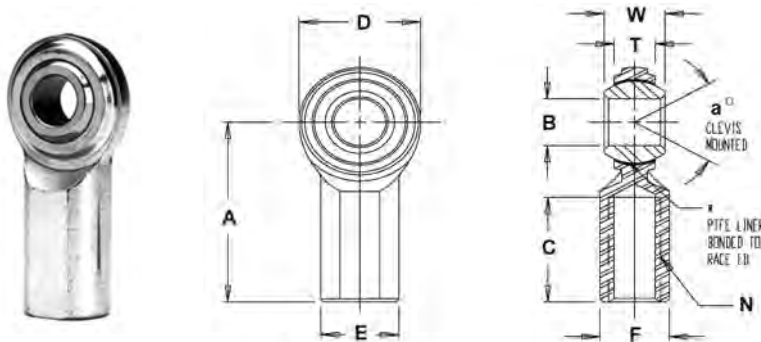

MATERIALS

BALL	BODY
440C STAINLESS STEEL HEAT TREATED	303 STAINLESS STEEL PASSIVATED
LINER	
*TEFLON FABRIC	

FEMALE ROD ENDS		B DIA.	D DIA.	W WIDTH	T WIDTH	BALL DIA.	A LGTH	N THD.	C LGTH	E DIA.	F FLAT	a° MIS. ANGLE	ULT. STATIC RADIAL LOAD (lbs.)	APPROX. WEIGHT (lbs.)
RIGHT HAND PART NO.	LEFT HAND PART NO.	+.0025 -.0005	+.010 -.010	+.005 -.005	REF.	REF.	+.015 -.015	UNF 2B	+.062 -.031	+.010 -.010	+.010 -.010	REF.		
SCF3T	SCFL3T	.1900	.625	.312	.234	.437	1.062	10-32	.500	.406	.312	20	930	.04
SCF4T	SCFL4T	.2500	.750	.375	.250	.500	1.312	1/4-28	.687	.468	.375	27	1,380	.05
SCF5T	SCFL5T	.3125	.875	.437	.312	.625	1.375	5/16-24	.687	.500	.437	22	2,100	.08
SCF6T	SCFL6T	.3750	1.000	.500	.359	.719	1.625	3/8-24	.812	.687	.562	22	3,080	.13
SCF7T	SCFL7T	.4375	1.125	.562	.406	.812	1.812	7/16-20	.937	.750	.625	21	3,790	.18
SCF8T	SCFL8T	.5000	1.312	.625	.453	.937	2.125	1/2-20	1.062	.875	.750	20	4,720	.29
SCF10T	SCFL10T	.6250	1.500	.750	.484	1.125	2.500	5/8-18	1.375	1.000	.875	26	5,870	.43
SCF12T	SCFL12T	.7500	1.750	.875	.593	1.312	2.875	3/4-16	1.562	1.125	1.000	24	7,520	.65

* A TRADE MARK OF E.I. DUPONT DE NEMOURS & CO., INC.



CM-M / CF-M

2-PIECE METRIC, METAL TO METAL

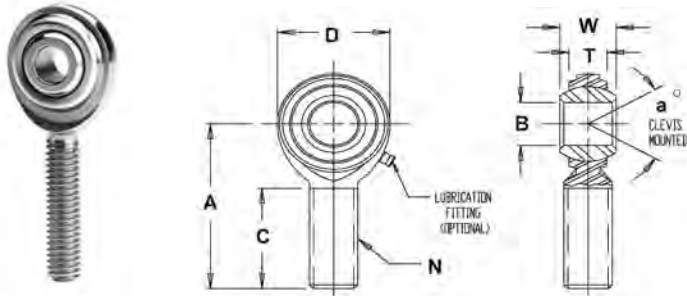

MATERIALS

BALL	BODY
52100 STEEL	LOW CARBON STEEL
Rc 56 MIN. HARDNESS	ZINC PLATED
HARD CHROME PLATED	CHROMATE TREATED

MALE ROD ENDS		B DIA.	D DIA.	W WIDTH	T WIDTH	BALL DIA.	A LGTH	N THD.	C LGTH	a° MIS. ANGLE	ULT. STATIC RADIAL LOAD Newtons	APPROX. WEIGHT (GRAMS)
RIGHT HAND PART NO.	LEFT HAND PART NO.	+0.065 -0.012	+0.038 -0.038	+0.12 -0.12	REF.	REF.	+0.40 -0.40	THREAD	+1.00 -1.00	REF.		
CM3M*	CML3M*	3	12.5	6	4.25	7.93	27	M3 X 0.5	15	23	1,775	7
CM5M*	CML5M*	5	16	8	5.75	11.10	33	M5 X 0.8	20	22	5,168	12
CM6M*	CML6M*	6	19	9	6.25	12.70	36	M6 X 1.0	22	23	7,296	18
CM8M*	CML8M*	8	22.25	12	8.0	15.88	42	M8 X 1.25	25	28	13,591	31
CM10M	CML10M	10	27	14	9.5	19.05	48	M10 X 1.5	29	26	21,024	68
CM12M	CML12M	12	30	16	10.75	22.23	54	M12 X 1.75	33	27	25,819	78
CM14M	CML14M	14	34.75	19	12.25	25.40	60	M14 X 2.0	36	30	35,214	118
CM16M	CML16M	16	38	21	12.75	28.58	66	M16 X 2.0	40	33	37,391	173
CM18M	CML18M	18	42	23	14.75	31.75	72	M18 X 1.5	44	30	47,903	260
CM20M	CML20M	20	46	25	16.25	34.93	78	M20 X 1.5	47	29	57,101	290

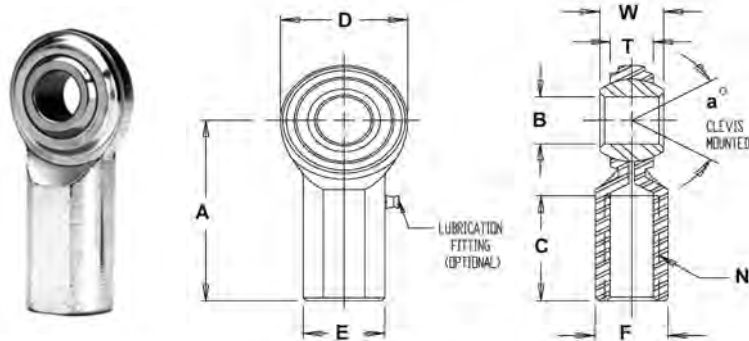

*GREASE FITTINGS ARE NOT SUPPLIED ON THESE SIZES. MALE ROD END LOAD RATINGS BASED ON NO LUBRICATING FITTING. FOR LOAD RATINGS WITH LUBRICATOR, PLEASE CONTACT THE F.K. ENGINEERING DEPARTMENT.

MATERIALS

BALL	BODY
52100 STEEL	LOW CARBON STEEL
Rc 56 MIN. HARDNESS	ZINC PLATED
HARD CHROME PLATED	CHROMATE TREATED

FEMALE ROD ENDS		B DIA.	D DIA.	W WIDTH	T WIDTH	BALL DIA.	A LGTH	N THD.	C LGTH	E DIA.	F FLAT	a° MIS. ANGLE	ULT. STATIC RADIAL LOAD Newtons	APPROX. WEIGHT (grams)
RIGHT HAND PART NO.	LEFT HAND PART NO.	+0.065 -0.012	+0.38 -0.38	+0.12 -0.12	REF.	REF.	+0.40 -0.40	THREAD	+1.00 -1.00	+0.25 -0.25	+0.25 -0.25	REF.		
CF3M*	CFL3M*	3	12.5	6	4.25	7.93	21	M3 X 0.5	10	8	7	23	5,746	10
CF5M*	CFL5M*	5	16	8	5.75	11.10	27	M5 X 0.8	14	11	9	22	8,247	18
CF6M*	CFL6M*	6	19	9	6.25	12.70	30	M6 X 1.0	14	13	11	23	11,895	25
CF8M*	CFL8M*	8	22.25	12	8.0	15.88	36	M8 X 1.25	17	16	14	28	15,190	40
CF10M	CFL10M	10	27	14	9.5	19.05	43	M10 X 1.5	21	19	17	26	22,750	80
CF12M	CFL12M	12	30	16	10.75	22.23	50	M12 X 1.75	24	22	19	27	25,819	95
CF14M	CFL14M	14	34.75	19	12.25	25.40	57	M14 X 2.0	27	25	22	30	35,214	160
CF16M	CFL16M	16	38	21	12.75	28.58	64	M16 X 2.0	33	27	22	33	37,391	215
CF18M	CFL18M	18	42	23	14.75	31.75	71	M18 X 1.5	36	28.58	25.4	30	47,903	300
CF20M	CFL20M	20	46	25	16.25	34.93	77	M20 X 1.5	40	30.15	27	29	57,101	350

NOTES: FOR GREASE FITTINGS ADD "Z" TO SUFFIX. EXAMPLE: CF6MZ



SCM-MT / SCF-MT

2-PIECE METRIC, STAINLESS STEEL, SELF-LUBRICATING

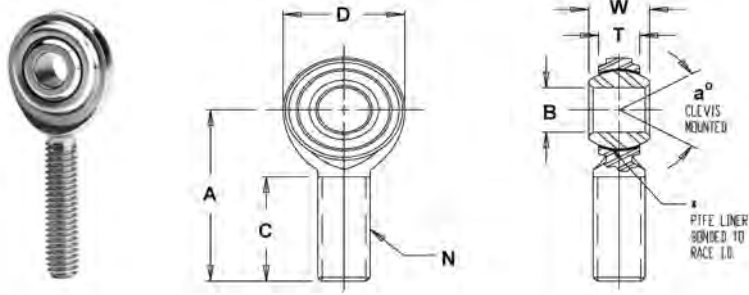

MATERIALS

BALL	BODY
440C STAINLESS STEEL HEAT TREATED	303 STAINLESS STEEL PASSIVATED
LINER	
*TEFLON FABRIC	

MALE ROD ENDS		B DIA.	D DIA.	W WIDTH	T WIDTH	BALL DIA.	A LGTH	N THD.	C LGTH	a° MIS. ANGLE	ULT. STATIC RADIAL LOAD Newtons	APPROX. WEIGHT (grams)
RIGHT HAND PART NO.	LEFT HAND PART NO.	+0.065 -0.012	+0.38 -0.38	+0.12 -0.12	REF.	REF.	+0.40 -0.40	THREAD	+1.00 -1.00	REF.		
SCM5MT	SCML5MT	5	16	8	5.75	11.10	33	M5 X 0.8	20	22	4,056	12
SCM6MT	SCML6MT	6	19	9	6.25	12.70	36	M6 X 1.0	22	23	6,093	18
SCM8MT	SCML8MT	8	22.25	12	8.0	15.88	42	M8 X 1.25	25	28	9,118	31
SCM10M	SCML10MT	10	27	14	9.5	19.05	48	M10 X 1.5	29	26	14,144	68
SCM12MT	SCML12MT	12	30	16	10.75	22.23	54	M12 X 1.75	33	27	17,373	78
SCM14MT	SCML14MT	14	34.75	19	12.25	25.40	60	M14 X 2.0	36	30	23,699	118
SCM16MT	SCML16MT	16	38	21	12.75	28.58	66	M16 X 2.0	40	33	25,162	173

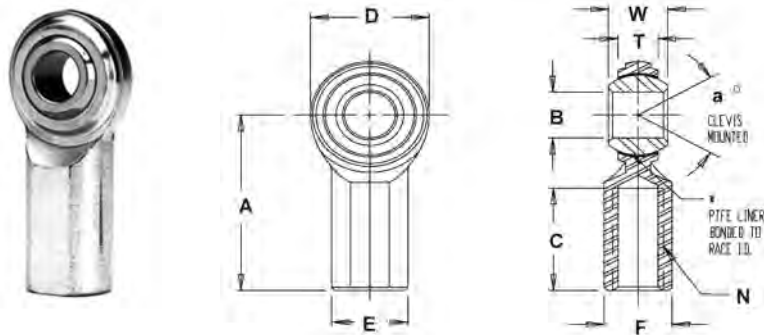

MATERIALS

BALL	BODY
440C STAINLESS STEEL HEAT TREATED	303 STAINLESS STEEL PASSIVATED
LINER	
*TEFLON FABRIC	

FEMALE ROD ENDS		B DIA.	D DIA.	W WIDTH	T WIDTH	BALL DIA.	A LGTH	N THD.	C LGTH	E DIA.	F FLAT	a° MIS. ANGLE	ULT. STATIC RADIAL LOAD Newtons	APPROX. WEIGHT (grams)
RIGHT HAND PART NO.	LEFT HAND PART NO.	+0.065 -0.012	+0.38 -0.38	+0.12 -0.12	REF.	REF.	+0.40 -0.40	THREAD	+1.00 -1.00	+0.25 -0.25	+0.25 -0.25	REF.		
SCF5MT	SCFL5MT	5	16	8	5.75	11.10	27	M5 X 0.8	14	11	9	22	4,136	18
SCF6MT	SCFL6MT	6	19	9	6.25	12.70	30	M6 X 1.0	14	13	11	23	6,138	25
SCF8MT	SCFL8MT	8	22.25	12	8.0	15.88	36	M8 X 1.25	17	16	14	28	9,340	40
SCF10MT	SCFL10MT	10	27	14	9.5	19.05	43	M10 X 1.5	21	19	17	26	15,310	80
SCF12MT	SCFL12MT	12	30	16	10.75	22.23	50	M12 X 1.75	24	22	19	27	17,373	95
SCF14MT	SCFL14MT	14	34.75	19	12.25	25.40	57	M14 X 2.0	27	25	22	30	23,699	160
SCF16MT	SCFL16MT	16	38	21	12.75	28.58	64	M16 X 2.0	33	27	22	33	25,162	215

* A TRADE MARK OF E.I. DUPONT DE NEMOURS & CO., INC.



CM-Y / CF-Y

2-PIECE, METAL TO METAL WITH STUDS, PTFE LINERS AVAILABLE

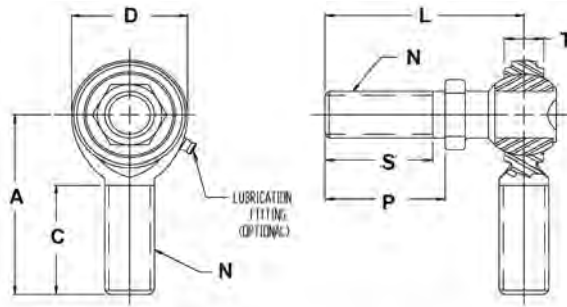

MATERIALS

BALL	BODY
52100 STEEL	LOW CARBON STEEL
Rc 56 MIN. HARDNESS	ZINC PLATED
HARD CHROME PLATED	CHROMATE TREATED
STUD	
LOW CARBON STEEL, ZINC PLATED	

MALE ROD ENDS		D DIA.	L LGTH	S LGTH	P LGTH	T WIDTH	A LGTH	N THD.	C LGTH	a° MIS. ANGLE	ULT. STATIC RADIAL LOAD (lbs.)	APPROX. WEIGHT (lbs.)
RIGHT HAND PART NO.	LEFT HAND PART NO.	+.010 -.010	+.015 -.015	MIN.	REF.	REF.	+.015 -.015	UNF 3A	+.062 -.031	REF.		
CM3Y*	CML3Y*	.625	1.016	.437	.500	.234	1.250	10-32	.750	45		.04
CM4Y*	CML4Y*	.750	1.031	.500	.562	.250	1.562	1/4-28	1.000	40		.05
CM5Y*	CML5Y*	.875	1.219	.593	.687	.312	1.875	5/16-24	1.250	42	CONSULT	.10
CM6Y	CML6Y	1.000	1.562	.812	.906	.359	1.938	3/8-24	1.250	46	F.K.	.15
CM7Y	CML7Y	1.125	1.750	.937	1.062	.406	2.125	7/16-20	1.375	44	ENG.	.24
CM8Y	CML8Y	1.312	2.000	1.000	1.125	.453	2.438	1/2-20	1.500	48	DEPT.	.35
CM10Y	CML10Y	1.500	2.500	1.375	1.500	.484	2.625	5/8-18	1.625	52		.61
CM12Y	CML12Y	1.750	3.000	1.625	1.812	.593	2.875	3/4-16	1.750	46		1.03

*GREASE FITTINGS ARE NOT SUPPLIED ON THESE SIZES. MALE ROD END LOAD RATINGS BASED ON NO LUBRICATING FITTING. FOR LOAD RATINGS WITH LUBRICATOR, PLEASE CONTACT THE F.K. ENGINEERING DEPARTMENT.

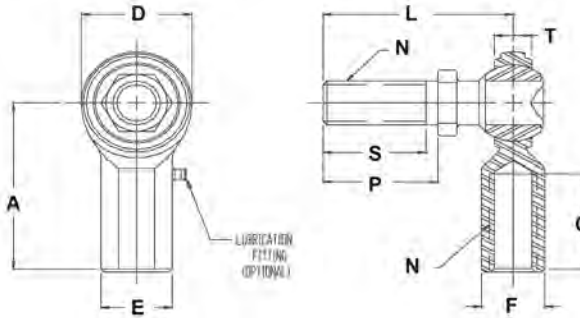

MATERIALS

BALL	BODY
52100 STEEL	LOW CARBON STEEL
Rc 56 MIN. HARDNESS	ZINC PLATED
HARD CHROME PLATED	CHROMATE TREATED
STUD	
LOW CARBON STEEL, ZINC PLATED	

FEMALE ROD ENDS		D DIA.	L LGTH	S LGTH	P LGTH	T WIDTH	A LGTH	N THD.	C LGTH	E DIA.	F FLAT	a° MIS. ANGLE	ULT. STATIC RADIAL LOAD (lbs.)	APPROX. WEIGHT (lbs.)
RIGHT HAND PART NO.	LEFT HAND PART NO.	+.010 -.010	+.015 -.015	MIN.	REF.	REF.	+.015 -.015	UNF 3A-2B	+.062 -.031	+.010 -.010	+.010 -.010	REF.		
CF3Y*	CFL3Y*	.625	1.016	.437	.500	.234	1.062	10-32	.500	.406	.312	45		.05
CF4-3Y	N/A	.750	1.031	.500	.562	.250	1.312	10-32	.687	.468	.375	40		.06
CF4Y	CFL4Y	.750	1.031	.500	.562	.250	1.312	1/4-28	.687	.468	.375	40		.06
CF5Y	CFL5Y	.875	1.219	.593	.687	.312	1.375	5/16-24	.687	.500	.437	42	CONSULT	.11
CF6Y	CFL6Y	1.000	1.562	.812	.906	.359	1.625	3/8-24	.812	.687	.562	46	F.K.	.17
CF7Y	CFL7Y	1.125	1.750	.937	1.062	.406	1.812	7/16-20	.937	.750	.625	44	ENG.	.27
CF8Y	CFL8Y	1.312	2.000	1.000	1.125	.453	2.125	1/2-20	1.062	.875	.750	48	DEPT.	.40
CF10Y	CFL10Y	1.500	2.500	1.375	1.500	.484	2.500	5/8-18	1.375	1.000	.875	52		.68
CF12Y	CFL12Y	1.750	3.000	1.625	1.812	.593	2.875	3/4-16	1.562	1.125	1.000	46		1.11

NOTES: FOR GREASE FITTINGS ADD "Z" TO SUFFIX. EXAMPLE: CF6YZ
 FOR RIGHT HAND STUD ADD "Y" TO SUFFIX. EXAMPLE: CM10Y
 FOR LEFT HAND STUD ADD "YL" TO SUFFIX. EXAMPLE: CM10YL
 FOR HEAT TREATED STUD ADD "YX" TO SUFFIX. EXAMPLE: CM10YX



CM SPECIAL

2-PIECE, METAL TO METAL, SPECIAL BORE SIZES / PTFE LINERS AVAILABLE

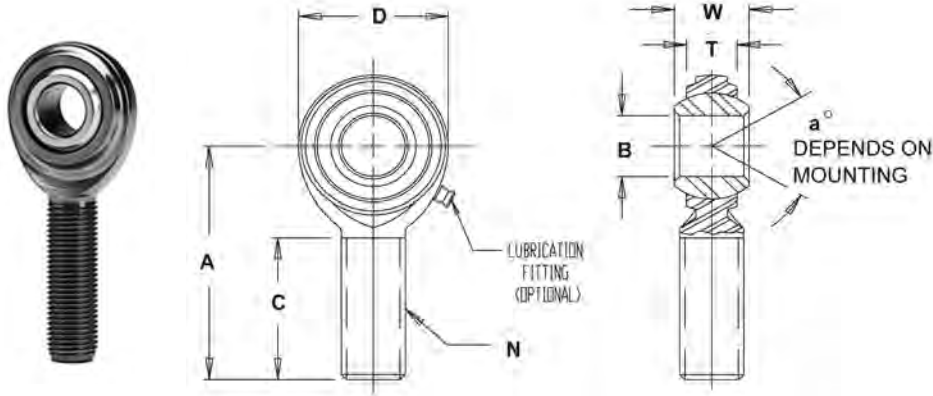

MATERIALS

BALL
52100 STEEL Rc 56 MIN. HARDNESS HARD CHROME PLATED
BODY
LOW CARBON STEEL ZINC PLATED CHROMATE TREATED

MALE ROD ENDS		B DIA.	D DIA.	W WIDTH	T WIDTH	BALL DIA.	A LGTH	N THD.	C LGTH	ULT. STATIC RADIAL LOAD (lbs.)	APPROX. WEIGHT (lbs.)
RIGHT HAND PART NO.	LEFT HAND PART NO.	+ .0025 - .0005	+ .010 - .010	+ .005 - .005	REF.	REF.	+ .015 - .015	UNF 3A	+ .062 - .031		
CM4-3	CML4-3	.1900	.750	.375	.250	.500	1.562	1/4-28	1.000	2,225	.042
CM5-4	CML5-4	.2500	.875	.437	.312	.625	1.875	5/16-24	1.250	3,600	.074
CM6-5	CML6-5	.3125	1.000	.500	.359	.719	1.938	3/8-24	1.250	5,100	.108
HCM6	HCML6	.3750	1.000	.750	.359	.719	1.938	3/8-24	1.250	5,100	.110
CM8-6	CML8-6	.3750	1.312	.625	.453	.937	2.438	1/2-20	1.500	8,386	.246
HCM8	HCML8	.5000	1.312	1.156	.453	.937	2.438	1/2-20	1.500	8,386	.256
CM10-8	CML10-8	.5000	1.500	.750	.484	1.125	2.625	5/8-18	1.625	9,813	.380
CM12-8	CML12-8	.5000	1.750	.875	.593	1.312	2.875	3/4-16	1.750	14,290	.626
CM12-10	CML12-10	.6250	1.750	.875	.593	1.312	2.875	3/4-16	1.750	14,290	.596
CM10-12Z	CML10-12Z	.6250	1.750	.875	.593	1.312	2.875	5/8-18	1.750	*	.532
HCM12	HCML12	.7500	1.750	1.125	.593	1.312	2.875	3/4-16	1.750	14,290	.582
CM12-757	CML12-757	.7570	1.750	.875	.593	1.312	2.875	3/4-16	1.750	14,290	.560

* CONSULT F.K. ENGINEERING DEPARTMENT.



NJM / NJF

3-PIECE, PRECISION - WEAR RESISTANT, PLASTIC RACE ROD ENDS

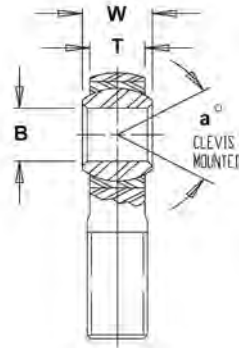
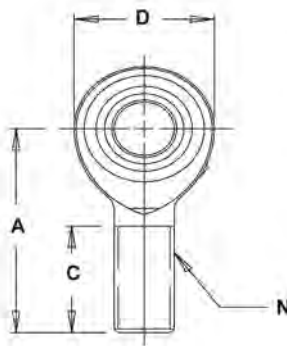

MATERIALS

BALL	BODY
LOW CARBON STEEL	LOW CARBON STEEL
CASE HARDENED	ZINC PLATED
ZINC PLATED	CHROMATE TREATED
RACE	
TEFLON LUBRICATED, FIBER REINFORCED ENGINEERING PLASTIC	

MALE ROD ENDS		B DIA.	D DIA.	W WIDTH	T WIDTH	BALL DIA.	A LGTH	N THD.	C LGTH	a° MIS. ANGLE	ULT. STATIC RADIAL LOAD (lbs.)	APPROX. WEIGHT (lbs.)
RIGHT HAND PART NO.	LEFT HAND PART NO.	+ .0025 - .0005	+ .010 - .010	+ .005 - .005	+ .015 - .015	REF.	+ .015 - .015	UNF 3A	+ .062 - .031	REF.		
NJM3	NJML3	.1900	.625	.312	.250	.437	1.250	10-32	.750	13	1,174	.03
NJM4	NJML4	.2500	.750	.375	.281	.500	1.562	1/4-28	1.000	16	2,168	.04
NJM5	NJML5	.3125	.875	.437	.344	.625	1.875	5/16-24	1.250	14	2,796	.07
NJM6	NJML6	.3750	1.000	.500	.406	.719	1.938	3/8-24	1.250	12	4,012	.11
NJM7	NJML7	.4375	1.125	.562	.437	.812	2.125	7/16-20	1.375	14	4,244	.16
NJM8	NJML8	.5000	1.312	.625	.500	.937	2.438	1/2-20	1.500	12	6,453	.25
NJM10	NJML10	.6250	1.500	.750	.562	1.125	2.625	5/8-18	1.625	16	7,400	.38
NJM12	NJML12	.7500	1.750	.875	.687	1.312	2.875	3/4-16	1.750	14	10,937	.60

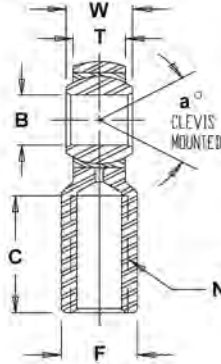
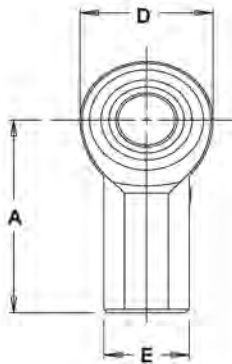

MATERIALS

BALL	BODY
LOW CARBON STEEL	LOW CARBON STEEL
CASE HARDENED	ZINC PLATED
ZINC PLATED	CHROMATE TREATED
RACE	
TEFLON LUBRICATED, FIBER REINFORCED ENGINEERING PLASTIC	

FEMALE ROD ENDS		B DIA.	D DIA.	W WIDTH	T WIDTH	BALL DIA.	A LGTH	N THD.	C LGTH	E DIA.	F FLAT	a° MIS. ANGLE	ULT. STATIC RADIAL LOAD (lbs.)	APPROX. WEIGHT (lbs.)
RIGHT HAND PART NO.	LEFT HAND PART NO.	+ .0025 - .0005	+ .010 - .010	+ .005 - .005	+ .015 - .015	REF.	+ .015 - .015	UNF 2B	+ .062 - .031	+ .010 - .010	+ .010 - .010	REF.		
NJF3	NJFL3	.1900	.625	.312	.250	.437	1.062	10-32	.500	.406	.312	13	1,220	.04
NJF4	NJFL4	.2500	.750	.375	.281	.500	1.312	1/4-28	.687	.469	.375	16	2,500	.06
NJF5	NJFL5	.3125	.875	.437	.344	.625	1.375	5/16-24	.687	.500	.437	14	2,753	.09
NJF6	NJFL6	.3750	1.000	.500	.406	.719	1.625	3/8-24	.812	.687	.562	12	3,950	.15
NJF7	NJFL7	.4375	1.125	.562	.437	.812	1.812	7/16-20	.937	.750	.625	14	4,300	.20
NJF8	NJFL8	.5000	1.312	.625	.500	.937	2.125	1/2-20	1.062	.875	.750	12	6,453	.33
NJF10	NJFL10	.6250	1.500	.750	.562	1.125	2.500	5/8-18	1.375	1.000	.875	16	7,400	.48
NJF12	NJFL12	.7500	1.750	.875	.687	1.312	2.875	3/4-16	1.562	1.125	1.000	14	10,937	.72

NOTES: FOR STUDS ADD "Y" TO SUFFIX. EXAMPLE: NJM6Y



M-SB / F-SB

3-PIECE, COMMERCIAL, SINTERED BRONZE

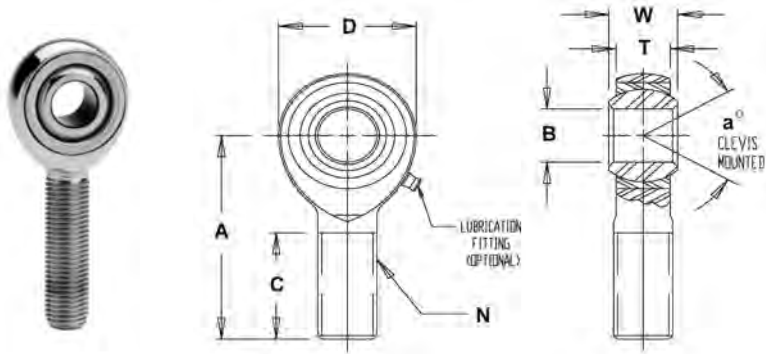

MATERIALS

BALL	BODY
52100 STEEL	LOW CARBON STEEL
Rc 56 MIN. HARDNESS	ZINC PLATED
HARD CHROME PLATED	CHROMATE TREATED
RACE	
SINTERED PHOSPHOR BRONZE	
OIL IMPREGNATED	

MALE ROD ENDS		B DIA.	D DIA.	W WIDTH	T WIDTH	BALL DIA.	A LGTH	N THD.	C LGTH	a° MIS. ANGLE	ULT. STATIC RADIAL LOAD (lbs.)	APPROX. WEIGHT (lbs.)
RIGHT HAND PART NO.	LEFT HAND PART NO.	+.0025 -.0005	+.010 -.010	+.005 -.005	+.015 -.015	REF.	+.015 -.015	UNF 3A	+.062 -.031	REF.		
M3SB	ML3SB	.1900	.625	.312	.250	.437	1.250	10-32	.750	13	1,174	.03
M4SB	ML4SB	.2500	.750	.375	.281	.500	1.562	1/4-28	1.000	16	2,168	.04
M5SB	ML5SB	.3125	.875	.437	.344	.625	1.875	5/16-24	1.250	14	2,796	.07
M6SB	ML6SB	.3750	1.000	.500	.406	.719	1.938	3/8-24	1.250	12	4,012	.11
M7SB	ML7SB	.4375	1.125	.562	.437	.812	2.125	7/16-20	1.375	14	4,244	.16
M8SB	ML8SB	.5000	1.312	.625	.500	.937	2.438	1/2-20	1.500	12	6,700	.25
M10SB	ML10SB	.6250	1.500	.750	.562	1.125	2.625	5/8-18	1.625	16	7,400	.38
M12SB	ML12SB	.7500	1.750	.875	.687	1.312	2.875	3/4-16	1.750	14	11,550	.60

MALE ROD END LOAD RATINGS BASED ON NO LUBRICATING FITTING. FOR LOAD RATINGS WITH LUBRICATOR, PLEASE CONTACT THE F.K. ENGINEERING DEPARTMENT.

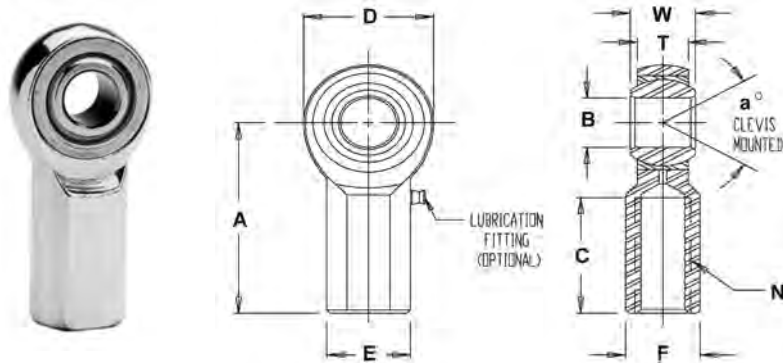

MATERIALS

BALL	BODY
52100 STEEL	LOW CARBON STEEL
Rc 56 MIN. HARDNESS	ZINC PLATED
HARD CHROME PLATED	CHROMATE TREATED
RACE	
SINTERED PHOSPHOR BRONZE	
OIL IMPREGNATED	

FEMALE ROD ENDS		B DIA.	D DIA.	W WIDTH	T WIDTH	BALL DIA.	A LGTH	N THD.	C LGTH	E DIA.	F FLAT	a° MIS. ANGLE	ULT. STATIC RADIAL LOAD (lbs.)	APPROX. WEIGHT (lbs.)
RIGHT HAND PART NO.	LEFT HAND PART NO.	+.0025 -.0005	+.010 -.010	+.005 -.005	+.015 -.015	REF.	+.015 -.015	UNF 2B	+.062 -.031	+.010 -.010	+.010 -.010	REF.		
F3SB	FL3SB	.1900	.625	.312	.250	.437	1.062	10-32	.500	.406	.312	13	1,624	.04
F4SB	FL4SB	.2500	.750	.375	.281	.500	1.312	1/4-28	.687	.468	.375	16	2,545	.06
F5SB	FL5SB	.3125	.875	.437	.344	.625	1.375	5/16-24	.687	.500	.437	14	3,200	.09
F6SB	FL6SB	.3750	1.000	.500	.406	.719	1.625	3/8-24	.812	.687	.562	12	3,950	.15
F7SB	FL7SB	.4375	1.125	.562	.437	.812	1.812	7/16-20	.937	.750	.625	14	4,300	.20
F8SB	FL8SB	.5000	1.312	.625	.500	.937	2.125	1/2-20	1.062	.875	.750	12	6,700	.33
F10SB	FL10SB	.6250	1.500	.750	.562	1.125	2.500	5/8-18	1.375	1.000	.875	16	7,400	.48
F12SB	FL12SB	.7500	1.750	.875	.687	1.312	2.875	3/4-16	1.562	1.125	1.000	14	11,550	.72

NOTES: FOR GREASE FITTINGS ADD "Z" TO SUFFIX. EXAMPLE: M6SBZ
FOR STUDS ADD "Y" TO SUFFIX. EXAMPLE: FL12SBY



JM / JML

3-PIECE, PRECISION-WEAR RESISTANT / PTFE LINERS AVAILABLE

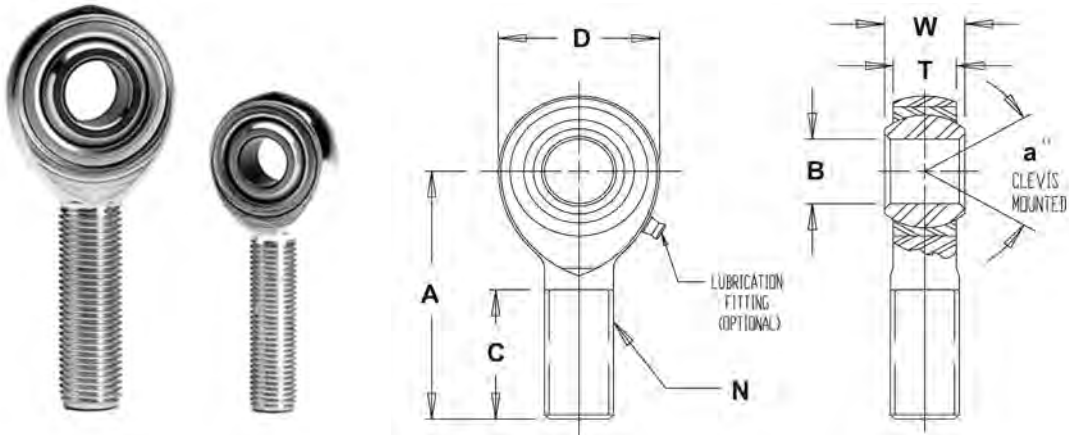

MALE ROD ENDS		B DIA.	D DIA.	W WIDTH	T WIDTH	BALL DIA.	A LGTH	N THD.	C LGTH	a° MIS. ANGLE	ULT. STATIC RADIAL LOAD (lbs.)	APPROX. WEIGHT (lbs.)
RIGHT HAND PART NO.	LEFT HAND PART NO.	+ .0025 - .0005	+ .010 - .010	+ .005 - .005	+ .015 - .015	REF.	+ .015 - .015	UNF 3A	+ .062 - .031	REF.		
JM2*	JML2*	.1250	.500	.250	.187	.312	.937	6-32 UNC	.562	16	500	.013
JM3	JML3	.1900	.625	.312	.250	.437	1.250	10-32	.750	13	1,174	.03
JM4	JML4	.2500	.750	.375	.281	.500	1.562	1/4-28	1.000	16	2,168	.04
JM5	JML5	.3125	.875	.437	.344	.625	1.875	5/16-24	1.250	14	2,796	.07
JM6	JML6	.3750	1.000	.500	.406	.719	1.938	3/8-24	1.250	12	4,012	.11
JM7	JML7	.4375	1.125	.562	.437	.812	2.125	7/16-20	1.375	14	4,244	.16
JM8	JML8	.5000	1.312	.625	.500	.937	2.438	1/2-20	1.500	12	6,700	.25
JM10	JML10	.6250	1.500	.750	.562	1.125	2.625	5/8-18	1.625	16	7,400	.38
JM12	JML12	.7500	1.750	.875	.687	1.312	2.875	3/4-16	1.750	14	11,550	.60
JM16**	JML16	1.0000	2.950	1.375	1.015	1.875	4.125	1-1/4-12	2.125	17	43,555	2.406
JM16-1**	JML16-1**	1.0000	2.950	1.375	1.015	1.875	4.125	1-14	2.125	17	43,555	2.127
JM16-2**	JML16-2**	1.0000	2.950	1.375	1.015	1.875	4.125	1-12	2.125	17	43,555	2.127

MALE ROD END LOAD RATINGS BASED ON NO LUBRICATION FITTING.

FOR LOAD RATINGS OF ROD ENDS WITH LUBRICATOR,
PLEASE CONTACT THE F.K. ENGINEERING DEPARTMENT

*GREASE FITTINGS & PTFE LINERS NOT AVAILABLE.

** TOLERANCE VARIATION: "D", "A" ARE +/- .020

MATERIALS

BALL	BODY
52100 STEEL	LOW CARBON STEEL
Rc 56 MIN. HARDNESS	ZINC PLATED
HARD CHROME PLATED	CHROMATE TREATED
RACE	
STEEL ALLOY, HEAT TREATED	
ZINC PLATED, CHROMATE TREATED	

NOTES:

FOR GREASE FITTINGS ADD "Z" TO SUFFIX. **EXAMPLE:** JM6Z

FOR STUDS ADD "Y" TO SUFFIX. **EXAMPLE:** JM5Y

FOR TEFLON LINER ADD "T" TO SUFFIX. **EXAMPLE:** JM12T

JF / JFL

3-PIECE, PRECISION-WEAR RESISTANT / PTFE LINERS AVAILABLE

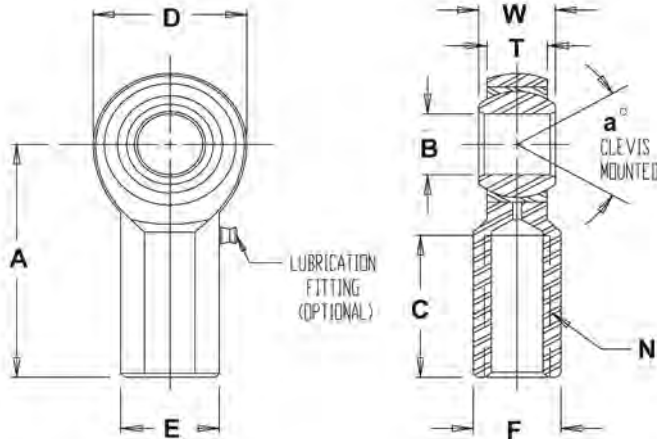

FEMALE ROD ENDS		B DIA.	D DIA.	W WIDTH	T WIDTH	BALL DIA.	A LGTH	N THD.	C LGTH	E DIA.	F FLAT	a° MIS. ANGLE	ULT. STATIC RADIAL LOAD (lbs.)	APPROX. WEIGHT (lbs.)
RIGHT HAND PART NO.	LEFT HAND PART NO.	+0.0015 -0.0005	+0.010 -0.010	+0.000 -0.005	+0.015 -0.015	REF.	+0.015 -0.015	UNF 2B	+0.062 -0.031	+0.010 -0.010	+0.010 -0.010	REF.		
JF2*	JFL2*	.1250	.500	.250	.187	.312	.812	6-32UNC	.437	.312	.250	16	1,210	.019
JF3	JFL3	.1900	.625	.312	.250	.437	1.062	10-32	.500	.406	.312	13	1,624	.04
JF4	JFL4	.2500	.750	.375	.281	.500	1.312	1/4-28	.687	.469	.375	16	2,545	.06
JF5	JFL5	.3125	.875	.437	.344	.625	1.375	5/16-24	.687	.500	.437	14	3,200	.09
JF6	JFL6	.3750	1.000	.500	.406	.719	1.625	3/8-24	.812	.687	.562	12	3,950	.15
JF7	JFL7	.4375	1.125	.562	.437	.812	1.812	7/16-20	.937	.750	.625	14	4,300	.20
JF8	JFL8	.5000	1.312	.625	.500	.937	2.125	1/2-20	1.062	.875	.750	12	6,700	.33
JF10	JFL10	.6250	1.500	.750	.562	1.125	2.500	5/8-18	1.375	1.000	.875	16	7,400	.48
JF12	JFL12	.7500	1.750	.875	.687	1.312	2.875	3/4-16	1.562	1.125	1.000	14	11,550	.72
JF16**	JFL16**	1.0000	2.750	1.375	1.000	1.875	4.125	1-1/4-12	2.125	1.625	1.500	17	40,893	2.125
JF16-1**	JFL16-1**	1.0000	2.750	1.375	1.000	1.875	4.125	1-14	2.125	1.625	1.500	17	43,555	2.410
JF16-2**	JFL16-2**	1.0000	2.750	1.375	1.000	1.875	4.125	1-12	2.125	1.625	1.500	17	43,555	2.410

*GREASE FITTINGS & PTFE LINERS NOT AVAILABLE.

** TOLERANCE VARIATION: "D", "A" ARE +/- .020

MATERIALS

BALL	BODY
52100 STEEL	LOW CARBON STEEL
Rc 56 MIN. HARDNESS	ZINC PLATED
HARD CHROME PLATED	CHROMATE TREATED
RACE	
STEEL ALLOY, HEAT TREATED	
ZINC PLATED, CHROMATE TREATED	

NOTES:

FOR GREASE FITTINGS ADD "Z" TO SUFFIX. **EXAMPLE:** JF6Z

FOR STUDS ADD "Y" TO SUFFIX. **EXAMPLE:** JF5Y

FOR TEFLON LINER ADD "T" TO SUFFIX. **EXAMPLE:** JF12T



JMX / JMXL

3-PIECE, PRECISION - HIGH STRENGTH ALLOY / PTFE LINERS AVAILABLE

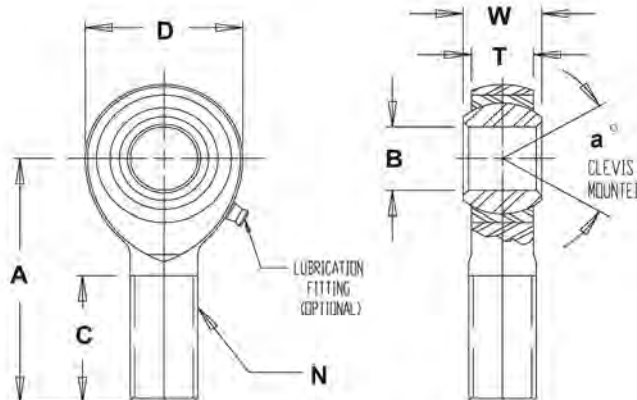

MALE ROD ENDS		B DIA.	D DIA.	W WIDTH	T WIDTH	BALL DIA.	A LGTH	N THD.	C LGTH	a° MIS. ANGLE	ULT. STATIC RADIAL LOAD (lbs.)	APPROX. WEIGHT (lbs.)
RIGHT HAND PART NO.	LEFT HAND PART NO.	+ .0015 - .0005	+ .010 - .010	+ .000 - .005	+ .005 - .005	REF.	+ .015 - .015	UNF 3A	+ .062 - .031	REF.		
JMX3	JMXL3	.1900	.625	.312	.250	.437	1.250	10-32	.750	13	2,855	.03
JMX4	JMXL4	.2500	.750	.375	.281	.500	1.562	1/4-28	1.000	16	5,262	.04
JMX5	JMXL5	.3125	.875	.437	.344	.625	1.875	5/16-24	1.250	14	7,640	.07
JMX6	JMXL6	.3750	1.000	.500	.406	.719	1.938	3/8-24	1.250	12	9,550	.11
JMX7	JMXL7	.4375	1.125	.562	.437	.812	2.125	7/16-20	1.375	14	10,290	.16
JMX8	JMXL8	.5000	1.312	.625	.500	.937	2.438	1/2-20	1.500	12	16,242	.25
JMX10	JMXL10	.6250	1.500	.750	.562	1.125	2.625	5/8-18	1.625	16	17,959	.38
JMX12	JMXL12	.7500	1.750	.875	.687	1.312	2.875	3/4-16	1.750	14	28,090	.60
JMX14	JMXL14	.8750	2.000	.875	.687	1.312	3.375	7/8-14	1.875	12	55,690	.91
JMX14T-770	JMXL14T-770	.8750	2.000	.875	.770	1.375	3.375	7/8-14	1.875	12	45,051	.91
JMX16**	JMXL16	1.0000	2.950	1.375	1.015	1.875	4.500	1-1/4-12	2.500	17	107,182	2.736
JMX16-1**	JMXL16-1	1.0000	2.950	1.375	1.015	1.875	4.500	1-14	2.500	17	107,182	2.464

MALE ROD END LOAD RATINGS BASED ON NO LUBRICATION FITTING.

FOR LOAD RATINGS OF ROD ENDS WITH LUBRICATOR, PLEASE CONTACT THE F.K. ENGINEERING DEPARTMENT.

** TOLERANCE VARIATION: "D", "A" ARE +/- .020

MATERIALS

BALL	BODY
52100 STEEL Rc 56 MIN. HARDNESS HARD CHROME PLATED	STEEL ALLOY, HEAT TREATED, ZINC PLATED CHROMATE TREATED
RACE	
STEEL ALLOY, HEAT TREATED ZINC PLATED, CHROMATE TREATED	

NOTES:

FOR GREASE FITTINGS ADD "Z" TO SUFFIX. **EXAMPLE:** JMX6Z
FOR STUDS ADD "Y" TO SUFFIX. **EXAMPLE:** JMX5Y
FOR TEFLON LINER ADD "T" TO SUFFIX. **EXAMPLE:** JMX12T



JFX / JFXL

3-PIECE, PRECISION - HIGH STRENGTH ALLOY / PTFE LINERS AVAILABLE

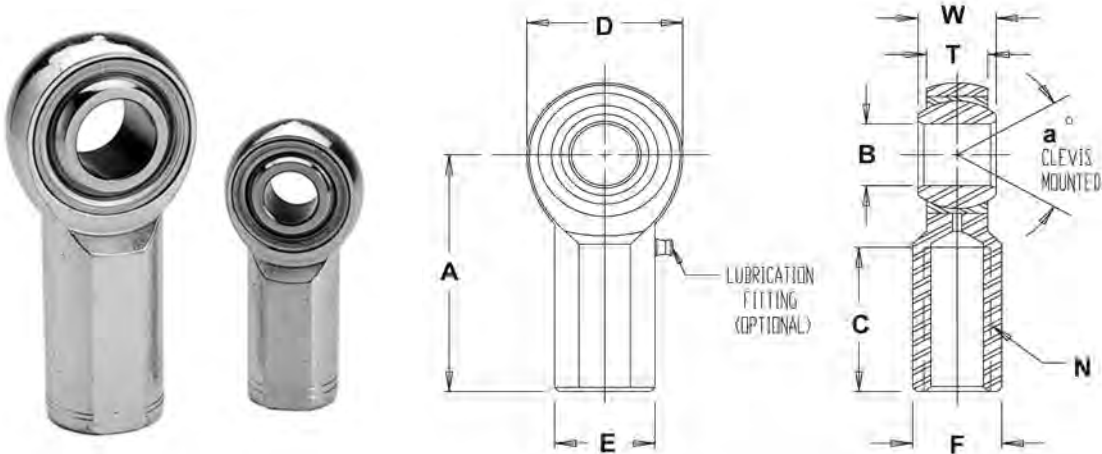

FEMALE ROD ENDS		B DIA.	D DIA.	W WIDTH	T WIDTH	BALL DIA.	A LGTH	N THD.	C LGTH	E DIA.	F FLAT	a° MIS. ANGLE	ULT. STATIC RADIAL LOAD (lbs.)	APPROX. WEIGHT (lbs.)
RIGHT HAND PART NO.	LEFT HAND PART NO.	+.0015 -.0005	+.010 -.010	+.000 -.005	+.005 -.005	REF.	+.015 -.015	UNF 2B	+.062 -.031	+.010 -.010	+.010 -.010	REF.		
JFX3	JFXL3	.1900	.625	.312	.250	.437	1.062	10-32	.500	.406	.312	13	3,736	.04
JFX4	JFXL4	.2500	.750	.375	.281	.500	1.312	1/4-28	.687	.469	.375	16	6,195	.06
JFX5	JFXL5	.3125	.875	.437	.344	.625	1.375	5/16-24	.687	.500	.437	14	7,640	.09
JFX6	JFXL6	.3750	1.000	.500	.406	.719	1.625	3/8-24	.812	.687	.562	12	9,550	.15
JFX7	JFXL7	.4375	1.125	.562	.437	.812	1.812	7/16-20	.937	.750	.625	14	10,290	.20
JFX8	JFXL8	.5000	1.312	.625	.500	.937	2.125	1/2-20	1.062	.875	.750	12	15,340	.33
JFX10	JFXL10	.6250	1.500	.750	.562	1.125	2.500	5/8-18	1.375	1.000	.875	16	17,959	.48
JFX12	JFXL12	.7500	1.750	.875	.687	1.312	2.875	3/4-16	1.562	1.125	1.000	14	28,090	.72
JFX16**	JFXL16**	1.0000	2.750	1.375	1.000	1.875	4.125	1-1/4-12	2.125	1.625	1.500	17	76,205	2.125
JFX16-1**	JFXL16-1**	1.0000	2.750	1.375	1.000	1.875	4.125	1-14	2.125	1.625	1.500	17	76,205	2.125
JFX24-1*	JFXL24-1*	1.5000	3.500	1.312	1.125	1.125	5.375	1 1/2-12	2.625	2.250	2.000	6.0	138,800	6.500

** TOLERANCE VARIATION: "D", "A" ARE +/- .020

* SOME DIMENSIONS HAVE GREATER TOLERANCE VARIATIONS.

MATERIALS

BALL	BODY
52100 STEEL	STEEL ALLOY, HEAT TREATED, ZINC PLATED
Rc 56 MIN. HARDNESS	TREATED, ZINC PLATED
HARD CHROME PLATED	CHROMATE TREATED
RACE	
STEEL ALLOY, HEAT TREATED	
ZINC PLATED, CHROMATE TREATED	

NOTES:

FOR GREASE FITTINGS ADD "Z" TO SUFFIX. **EXAMPLE:** JFX6Z

FOR STUDS ADD "Y" TO SUFFIX. **EXAMPLE:** JFX5Y

FOR TEFLON LINER ADD "T" TO SUFFIX. **EXAMPLE:** JFX12T



RSM / RSM-T

3-PIECE, EXTRA STRENGTH - HEAVY DUTY SHANK / PTFE LINERS AVAILABLE

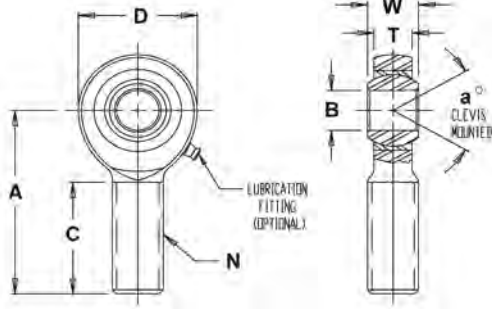

MATERIALS

BALL	BODY
52100 STEEL Rc 56 MIN. HARDNESS HARD CHROME PLATED	LOW CARBON STEEL ZINC PLATED CHROMATE TREATED
RACE	
STEEL ALLOY, HEAT TREATED ZINC PLATED, CHROMATE TREATED	

MALE ROD ENDS		B DIA.	D DIA.	W WIDTH	T WIDTH	BALL DIA.	A LGTH	N THD.	C LGTH	a° MIS. ANGLE	ULT. STATIC RADIAL LOAD (lbs.)	APPROX. WEIGHT (lbs.)
RIGHT HAND PART NO.	LEFT HAND PART NO.	+ .0015 - .0005	+ .010 - .010	+ .000 - .005	+ .005 - .005	REF.	+ .015 - .015	UNF 3A	+ .062 - .031	REF.		
RSM3	RSML3	.1900	.750	.312	.250	.437	1.562	1/4-28	1.000	10	2,170	.043
RSM4	RSML4	.2500	.875	.375	.281	.500	1.875	5/16-24	1.250	13	3,523	.072
RSM5	RSML5	.3125	1.000	.437	.344	.625	1.938	3/8-24	1.250	12	5,370	.112
RSM6	RSML6	.3750	1.125	.500	.406	.719	2.125	7/16-20	1.375	10	7,230	.160
RSM7	RSML7	.4375	1.312	.562	.437	.812	2.438	1/2-20	1.500	12	9,685	.249
RSM8	RSML8	.5000	1.500	.625	.500	.937	2.625	5/8-18	1.625	10	12,843	.382
RSM10	RSML10	.6250	1.750	.750	.562	1.125	2.875	3/4-16	1.750	13	16,613	.602

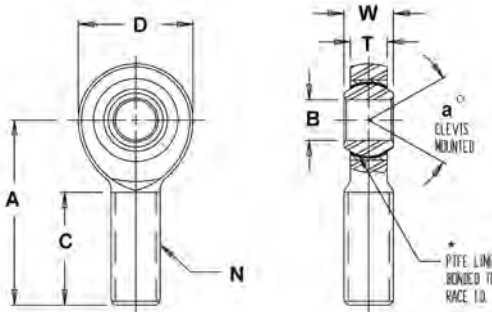

MATERIALS

BALL	BODY
52100 STEEL Rc 56 MIN. HARDNESS HARD CHROME PLATED	LOW CARBON STEEL ZINC PLATED CHROMATE TREATED
RACE	
STEEL ALLOY, HEAT TREATED ZINC PLATED CHROMATE TREATED	*TEFLON FABRIC

MALE ROD ENDS		B DIA.	D DIA.	W WIDTH	T WIDTH	BALL DIA.	A LGTH	N THD.	C LGTH	a° MIS. ANGLE	ULT. STATIC RADIAL LOAD (lbs.)	APPROX. WEIGHT (lbs.)
RIGHT HAND PART NO.	LEFT HAND PART NO.	+ .0015 - .0005	+ .010 - .010	+ .000 - .005	+ .005 - .005	REF.	+ .015 - .015	UNF 3A	+ .062 - .031	REF.		
RSM3T	RSML3T	.1900	.750	.312	.250	.437	1.562	1/4-28	1.000	10	2,170	.043
RSM4T	RSML4T	.2500	.875	.375	.281	.500	1.875	5/16-24	1.250	13	3,523	.072
RSM5T	RSML5T	.3125	1.000	.437	.344	.625	1.938	3/8-24	1.250	12	5,370	.112
RSM6T	RSML6T	.3750	1.125	.500	.406	.719	2.125	7/16-20	1.375	10	7,230	.160
RSM7T	RSML7T	.4375	1.312	.562	.437	.812	2.438	1/2-20	1.500	12	9,685	.249
RSM8T	RSML8T	.5000	1.500	.625	.500	.937	2.625	5/8-18	1.625	10	12,843	.382
RSM10T	RSML10T	.6250	1.750	.750	.562	1.125	2.875	3/4-16	1.750	13	16,613	.602

MALE ROD END LOAD RATINGS BASED ON NO LUBRICATION FITTING.
FOR LOAD RATINGS OF ROD ENDS WITH LUBRICATOR,
PLEASE CONTACT THE F.K. ENGINEERING DEPARTMENT.

NOTES: FOR GREASE FITTINGS ADD "Z" TO SUFFIX. EXAMPLE: RSML6Z

* A TRADE MARK OF E.I. DUPONT DE NEMOURS & CO., INC.



RSMX / RSMX-T

3-PIECE, HIGH STRENGTH ALLOY - HEAVY DUTY SHANK / PTFE LINERS AVAILABLE

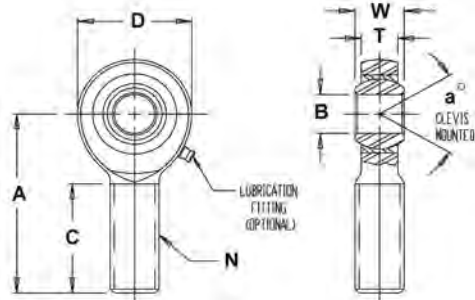

MATERIALS

BALL	BODY
52100 STEEL	STEEL ALLOY, HEAT TREATED
Rc 56 MIN. HARDNESS	ZINC PLATED
HARD CHROME PLATED	CHROMATE TREATED
RACE	
STEEL ALLOY, HEAT TREATED	
ZINC PLATED, CHROMATE TREATED	

MALE ROD ENDS		B DIA.	D DIA.	W WIDTH	T WIDTH	BALL DIA.	A LGTH	N THD.	C LGTH	a° MIS. ANGLE	ULT. STATIC RADIAL LOAD (lbs.)	APPROX. WEIGHT (lbs.)
RIGHT HAND PART NO.	LEFT HAND PART NO.	+ .0015 - .0005	+ .010 - .010	+ .000 - .005	+ .005 - .005	REF.	+ .015 - .015	UNF 3A	+ .062 - .031	REF.		
RSMX3	RSMXL3	.1900	.750	.312	.250	.437	1.562	1/4-28	1.000	10	5,270	.043
RSMX4	RSMXL4	.2500	.875	.375	.281	.500	1.875	5/16-24	1.250	13	8,471	.072
RSMX5	RSMXL5	.3125	1.000	.437	.344	.625	1.938	3/8-24	1.250	12	13,012	.112
RSMX6	RSMXL6	.3750	1.125	.500	.406	.719	2.125	7/16-20	1.375	10	17,610	.160
RSMX7	RSMXL7	.4375	1.312	.562	.437	.812	2.438	1/2-20	1.500	12	23,470	.249
RSMX8	RSMXL8	.5000	1.500	.625	.500	.937	2.625	5/8-18	1.625	10	31,420	.382
RSMX10-8	RSMXL10-8	.5000	1.750	.750	.562	1.125	2.875	3/4-16	1.750	13	40,590	.602
RSMX10	RSMXL10	.6250	1.750	.750	.562	1.125	2.875	3/4-16	1.750	13	40,590	.602
RSMX12	RSMXL12	.7500	2.000	.875	.687	1.312	3.375	7/8-14	1.875	12	55,696	.918

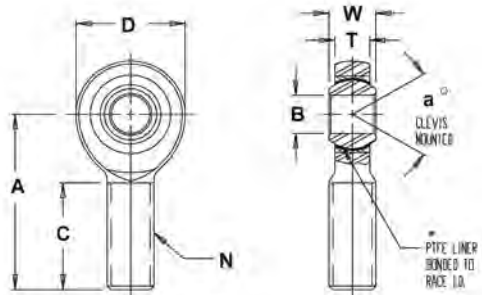

MATERIALS

BALL	BODY
52100 STEEL	STEEL ALLOY, HEAT TREATED
Rc 56 MIN. HARDNESS	ZINC PLATED
HARD CHROME PLATED	CHROMATE TREATED
RACE	
STEEL ALLOY, HEAT TREATED, ZINC PLATED	*TEFLON FABRIC
CHROMATE TREATED	

MALE ROD ENDS		B DIA.	D DIA.	W WIDTH	T WIDTH	BALL DIA.	A LGTH	N THD.	C LGTH	a° MIS. ANGLE	ULT. STATIC RADIAL LOAD (lbs.)	APPROX. WEIGHT (lbs.)
RIGHT HAND PART NO.	LEFT HAND PART NO.	+ .0015 - .0005	+ .010 - .010	+ .000 - .005	+ .005 - .005	REF.	+ .015 - .015	UNF 3A	+ .062 - .031	REF.		
RSMX3T	RSMXL3T	.1900	.750	.312	.250	.437	1.562	1/4-28	1.000	10	5,270	.043
RSMX4T	RSMXL4T	.2500	.875	.375	.281	.500	1.875	5/16-24	1.250	13	8,471	.072
RSMX5T	RSMXL5T	.3125	1.000	.437	.344	.625	1.938	3/8-24	1.250	12	13,012	.112
RSMX6T	RSMXL6T	.3750	1.125	.500	.406	.719	2.125	7/16-20	1.375	10	17,610	.160
RSMX7T	RSMXL7T	.4375	1.312	.562	.437	.812	2.438	1/2-20	1.500	12	23,470	.249
RSMX8T	RSMXL8T	.5000	1.500	.625	.500	.937	2.625	5/8-18	1.625	10	31,420	.382
RSMX10-8T	RSMXL10-8T	.5000	1.750	.750	.562	1.125	2.875	3/4-16	1.750	13	40,590	.602
RSMX10T	RSMXL10T	.6250	1.750	.750	.562	1.125	2.875	3/4-16	1.750	13	40,590	.602
RSMX12T	RSMXL12T	.7500	2.000	.875	.687	1.312	3.375	7/8-14	1.875	12	55,696	.918
RSMX14T**	RSMXL14T**	.8750	2.312	.875	.765	1.375	3.800	1-14	2.375	12	63,096	1.302

* A TRADE MARK OF E.I. DUPONT DE NEMOURS & CO., INC.

** RACE IS 17-4PH STAINLESS STEEL, HEAT TREATED / BALL IS 440C STAINLESS STEEL OR 52100 STEEL (HEAT TREATED) - MANUFACTURE'S OPTION

MALE ROD END LOAD RATINGS BASED ON NO LUBRICATION FITTING. FOR LOAD RATINGS OF ROD ENDS WITH LUBRICATOR, PLEASE CONTACT THE F.K. ENGINEERING DEPARTMENT.

NOTES: FOR GREASE FITTINGS ADD "Z" TO SUFFIX.
EXAMPLE: RSMXL5Z



CMX / CMX-T

2-PIECE, METAL TO METAL, HEAT TREATED, ALLOY STEEL / PTFE LINERS AVAILABLE

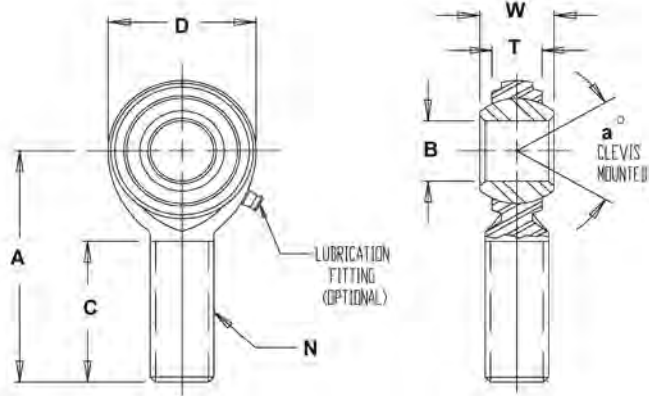

MATERIALS

BALL
52100 STEEL Rc 56 MIN. HARDNESS HARD CHROME PLATED
BODY
ALLOY STEEL HEAT TREATED BLACK OXIDE COATED

MALE ROD ENDS		B DIA.	D DIA.	W WIDTH	T WIDTH	BALL DIA.	A LGTH	N THD.	C LGTH	a° MIS. ANGLE	ULT. STATIC RADIAL LOAD (lbs.)	APPROX. WEIGHT (lbs.)
RIGHT HAND PART NO.	LEFT HAND PART NO.	+.0025 -.0005	+.010 -.010	+.005 -.005	REF.	REF.	+.015 -.015	UNF 3A	+.062 -.031	REF.		
CMX8	CMXL8	.5000	1.312	.625	.453	.937	2.438	1/2-20	1.500	20	17,000	.24
CMX10-8	CMXL10-8	.5000	1.500	.750	.484	1.125	2.625	5/8-18	1.625	26	18,000	.30
CMX10	CMXL10	.6250	1.500	.750	.484	1.125	2.625	5/8-18	1.625	26	18,000	.36
CMX12-8	CMXL12-8	.5000	1.750	.875	.593	1.312	2.875	3/4-16	1.750	24	25,000	.57
CMX12-10	CMXL12-10	.6250	1.750	.875	.593	1.312	2.875	3/4-16	1.750	24	25,000	.57
CMX12	CMXL12	.7500	1.750	.875	.593	1.312	2.875	3/4-16	1.750	24	25,000	.57

MALE ROD END LOAD RATINGS BASED ON NO LUBRICATION FITTING. FOR LOAD RATINGS OF ROD ENDS WITH LUBRICATOR, PLEASE CONTACT THE F.K. ENGINEERING DEPARTMENT.

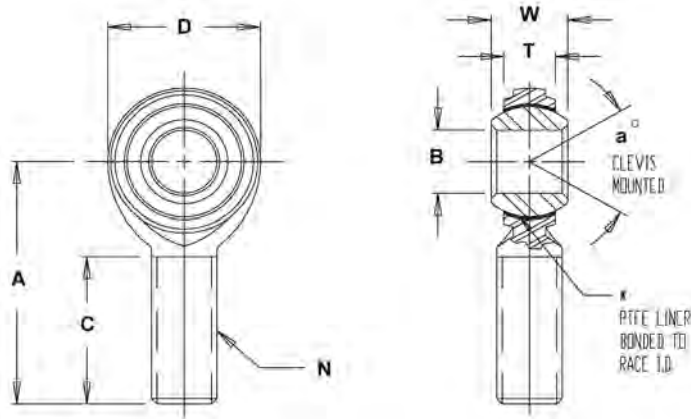

MATERIALS

BALL
52100 STEEL Rc 56 MIN. HARDNESS HARD CHROME PLATED
BODY
ALLOY STEEL HEAT TREATED BLACK OXIDE COATED
LINER
*TEFLON FABRIC

MALE ROD ENDS		B DIA.	D DIA.	W WIDTH	T WIDTH	BALL DIA.	A LGTH	N THD.	C LGTH	a° MIS. ANGLE	ULT. STATIC RADIAL LOAD (lbs.)	APPROX. WEIGHT (lbs.)
RIGHT HAND PART NO.	LEFT HAND PART NO.	+.0025 -.0005	+.010 -.010	+.005 -.005	REF.	REF.	+.015 -.015	UNF 3A	+.062 -.031	REF.		
CMX8T	CMXL8T	.5000	1.312	.625	.453	.937	2.438	1/2-20	1.500	20	14,500	.24
CMX10-8T	CMXL10-8T	.5000	1.500	.750	.484	1.125	2.625	5/8-18	1.625	26	15,200	.30
CMX10T	CMXL10T	.6250	1.500	.750	.484	1.125	2.625	5/8-18	1.625	26	15,200	.36
CMX12-8T	CMXL12-8T	.5000	1.750	.875	.593	1.312	2.875	3/4-16	1.750	24	21,400	.57
CMX12-10T	CMXL12-10T	.6250	1.750	.875	.593	1.312	2.875	3/4-16	1.750	24	21,400	.57
CMX12T	CMXL12T	.7500	1.750	.875	.593	1.312	2.875	3/4-16	1.750	24	21,400	.57

* A TRADE MARK OF E.I. DUPONT DE NEMOURS & CO., INC.



KMX / KMXL

3-PIECE, ALLOY STEEL, HEAT TREATED - NYLON RACE

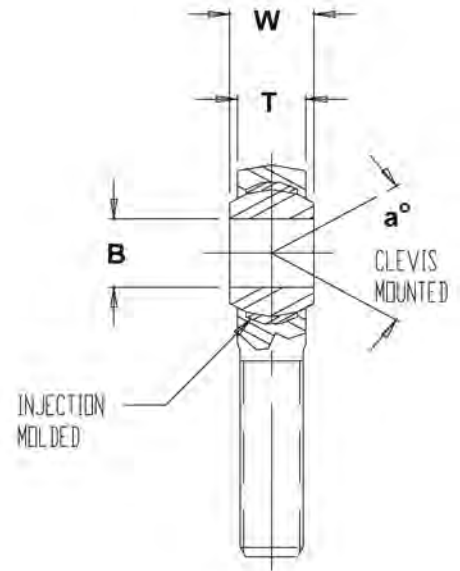
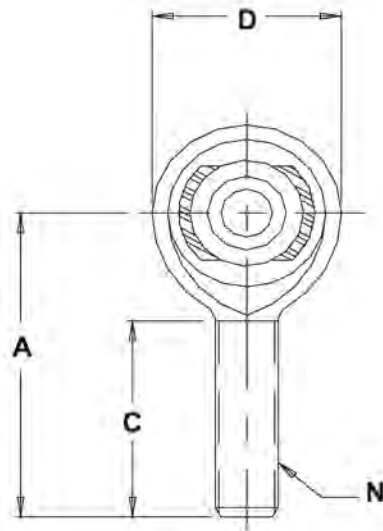

MALE ROD ENDS		B DIA.	D DIA.	W WIDTH	T WIDTH	BALL DIA.	A LGTH	N THD.	C LGTH	a° MIS. ANGLE	ULT. STATIC RADIAL LOAD (lbs.)	APPROX. WEIGHT (lbs.)
RIGHT HAND PART NO.	LEFT HAND PART NO.	+.0025 -.0005	+.010 -.010	+.005 -.005	+.005 -.005	REF.	+.015 -.015	UNF 3A	+.062 -.031	REF.		
KMX5	KMXL5	.3125	.875	.437	.344	.625	1.875	5/16-24	1.250	14	7,600	0.07
KMX6	KMXL6	.3750	1.000	.500	.406	.719	1.938	3/8-24	1.250	12	9,500	0.11
KMX8	KMXL8	.5000	1.312	.625	.500	.937	2.438	1/2-20	1.500	12	12,696	.24
KMX10-8	KMXL10-8	.5000	1.500	.625	.500	.937	2.625	5/8-18	1.625	12	19,960	.36
KMX10	KMXL10	.6250	1.500	.750	.562	1.125	2.625	5/8-18	1.625	16	14,480	.36
KMX12-8	KMXL12-8	.5000	1.750	.750	.562	1.125	2.875	3/4-16	1.750	14	23,256	.57
KMX12-10	KMXL12-10	.6250	1.750	.750	.562	1.125	2.875	3/4-16	1.750	14	23,256	.57
KMX12	KMXL12	.7500	1.750	.875	.687	1.312	2.875	3/4-16	1.750	14	23,192	.57

MATERIALS

BALL	BODY
52100 STEEL	ALLOY STEEL
Rc 56 MIN. HARDNESS	HEAT TREATED
HARD CHROME PLATED	CHROME PLATED
RACE	
NYLON 10 OR EQUIVALENT	

NOTES: FOR STUDS ADD "Y" TO SUFFIX.

EXAMPLE: KMX10Y



RJM / RJF

3-PIECE, PRECISION - CHROME PLATED / PTFE LINERS AVAILABLE

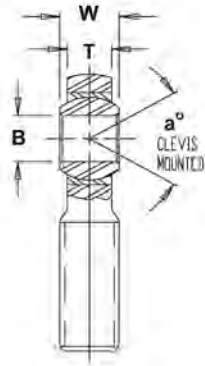
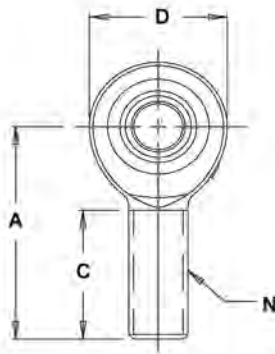

MATERIALS

BALL	BODY
52100 STEEL Rc 56 MIN. HARDNESS HARD CHROME PLATED	LOW CARBON STEEL DECORATIVE CHROME PLATED
RACE	
STEEL ALLOY HEAT TREATED ZINC PLATED, CHROMATE TREATED	

MALE ROD ENDS		B DIA.	D DIA.	W WIDTH	T WIDTH	BALL DIA.	A LGTH	N THD.	C LGTH	a° MIS. ANGLE	ULT. STATIC RADIAL LOAD (lbs.)	APPROX. WEIGHT (lbs.)
RIGHT HAND PART NO.	LEFT HAND PART NO.	+0.0015 -0.0005	+0.010 -0.010	+0.005 -0.005	+0.005 -0.005	REF.	+0.015 -0.015	UNF 3A	+0.062 -0.031	REF.		
RJM4	RJML4	.2500	.750	.375	.281	.500	1.562	1/4-28	1.000	16	2,168	.04
RJM5	RJML5	.3125	.875	.437	.344	.625	1.875	5/16-24	1.250	14	2,796	.07
RJM6	RJML6	.3750	1.000	.500	.406	.719	1.938	3/8-24	1.250	12	4,012	.11

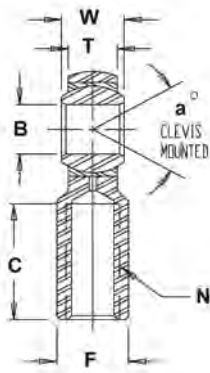
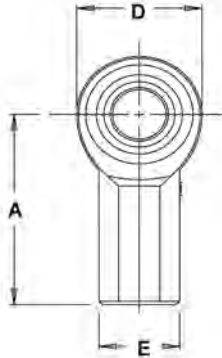

MATERIALS

BALL	BODY
52100 STEEL Rc 56 MIN. HARDNESS HARD CHROME PLATED	LOW CARBON STEEL DECORATIVE CHROME PLATED
RACE	
STEEL ALLOY HEAT TREATED ZINC PLATED, CHROMATE TREATED	

FEMALE ROD ENDS		B DIA.	D DIA.	W WIDTH	T WIDTH	BALL DIA.	A LGTH	N THD.	C LGTH	E DIA.	F FLAT	a° MIS. ANGLE	ULT. STATIC RADIAL LOAD (lbs.)	APPROX. WEIGHT (lbs.)
RIGHT HAND PART NO.	LEFT HAND PART NO.	+0.0015 -0.0005	+0.010 -0.010	+0.005 -0.005	+0.005 -0.005	REF.	+0.015 -0.015	UNF 2B	+0.062 -0.031	+0.010 -0.010	+0.010 -0.010	REF.		
RJF4	RJFL4	.2500	.750	.375	.281	.500	1.312	1/4-28	.687	.468	.375	16	2,545	.06
RJF5	RJFL5	.3125	.875	.437	.344	.625	1.375	5/16-24	.687	.500	.437	14	3,200	.09
RJF6	RJFL6	.3750	1.000	.500	.406	.719	1.625	3/8-24	.812	.687	.562	12	3,950	.15

* A TRADE MARK OF E.I. DUPONT DE NEMOURS & CO., INC.

NOTES: FOR *TEFLON LINER ADD "T" TO SUFFIX. EXAMPLE: RJF5T



RJMX-T / RRSMX-T

3-PIECE, HEAVY DUTY / EXTRA HEAVY DUTY WITH PTFE LINER

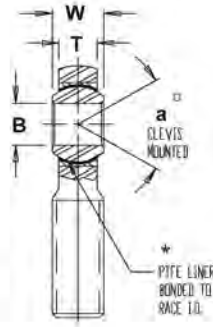
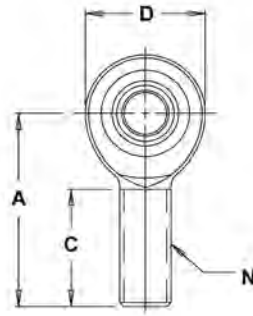

MATERIALS

BALL	BODY
52100 STEEL Rc 56 MIN. HARDNESS HARD CHROME PLATED	STEEL ALLOY, HEAT TREATED BRIGHT ELECTROLESS NICKEL OR HARD CHROME PLATED
RACE	LINER
STEEL ALLOY HEAT TREATED ZINC PLATED CHROMATE TREATED	*TEFLON FABRIC

RJMX - HEAVY DUTY

MALE ROD ENDS		B DIA.	D DIA.	W WIDTH	T WIDTH	BALL DIA.	A LGTH	N THD.	C LGTH	a° MIS. ANGLE	ULT. STATIC RADIAL LOAD (lbs.)	APPROX. WEIGHT (lbs.)
RIGHT HAND PART NO.	LEFT HAND PART NO.	+ .0015 - .0005	+ .010 - .010	+ .000 - .005	+ .005 - .005	REF.	+ .015 - .015	UNF 3A	+ .062 - .031	REF.		
RJMX6T	RJMXL6T	.3750	1.000	.500	.406	.719	1.938	3/8-24	1.250	12	9,550	.112
RJMX7T	RJMXL7T	.4375	1.125	.562	.437	.812	2.125	7/16-20	1.375	14	10,290	.160
RJMX8T	RJMXL8T	.5000	1.312	.625	.500	.937	2.438	1/2-20	1.500	12	16,242	.249
RJMX10T	RJMXL10T	.6250	1.500	.750	.562	1.125	2.625	5/8-18	1.625	16	17,959	.382
RJMX12T	RJMXL12T	.7500	1.750	.875	.687	1.312	2.875	3/4-16	1.750	14	28,090	.602

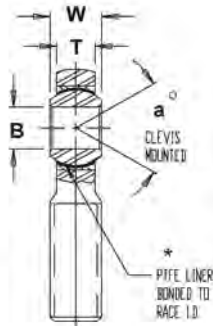
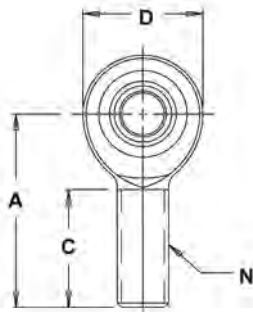

MATERIALS

BALL	BODY
52100 STEEL Rc 56 MIN. HARDNESS HARD CHROME PLATED	STEEL ALLOY, HEAT TREATED BRIGHT ELECTROLESS NICKEL OR HARD CHROME PLATED
RACE	LINER
STEEL ALLOY HEAT TREATED ZINC PLATED CHROMATE TREATED	*TEFLON FABRIC

RRSMX - EXTRA HEAVY DUTY

MALE ROD ENDS		B DIA.	D DIA.	W WIDTH	T WIDTH	BALL DIA.	A LGTH	N THD.	C LGTH	a° MIS. ANGLE	ULT. STATIC RADIAL LOAD (lbs.)	APPROX. WEIGHT (lbs.)
RIGHT HAND PART NO.	LEFT HAND PART NO.	+ .0015 - .0005	+ .010 - .010	+ .005 - .005	+ .005 - .005	REF.	+ .015 - .015	UNF 3A	+ .062 - .031	REF.		
RRSMX6T	RRSMXL6T	.3750	1.125	.500	.406	.719	2.125	7/16-20	1.375	10	17,610	.160
RRSMX7T	RRSMXL7T	.4375	1.312	.562	.437	.812	2.438	1/2-20	1.500	12	23,470	.249
RRSMX8T	RRSMXL8T	.5000	1.500	.625	.500	.937	2.625	5/8-18	1.625	10	31,420	.382
RRSMX10T	RRSMXL10T	.6250	1.750	.750	.562	1.125	2.875	3/4-16	1.750	13	40,590	.602

* A TRADE MARK OF E.I. DUPONT DE NEMOURS & CO., INC.



SJM-T / SRSM-T

3-PIECE, PRECISION - STAINLESS STEEL, WEAR RESISTANT, SELF-LUBRICATING

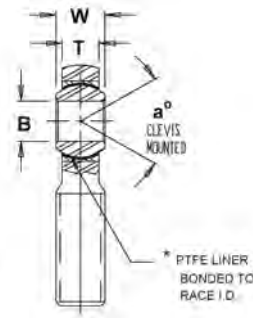
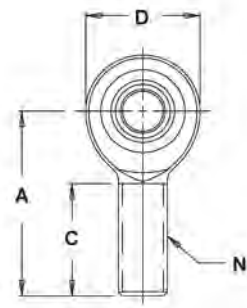

MATERIALS

BALL	BODY
440C CRES STAINLESS STEEL HEAT TREATED	17-4PH CRES STAINLESS STEEL HEAT TREATED
RACE	LINER
17-4PH CRES STAINLESS STEEL HEAT TREATED	*TEFLON FABRIC

SJM-T - STAINLESS STEEL PRECISION

MALE ROD ENDS		B DIA.	D DIA.	W WIDTH	T WIDTH	BALL DIA.	A LGTH	N THD.	C LGTH	a° MIS. ANGLE	ULT. STATIC RADIAL LOAD (lbs.)	APPROX. WEIGHT (lbs.)
RIGHT HAND PART NO.	LEFT HAND PART NO.	+.0000 -.0005	+.010 -.010	+.000 -.002	+.005 -.005	REF.	+.010 -.010	UNF 3A	+.031 -.031	REF.		
SJM4T	SJML4T	.2500	.806	.437	.337	.531	1.562	1/4-28	.968	11	4,874	.072
SJM5T	SJML5T	.3125	.900	.437	.327	.593	1.875	5/16-24	1.187	11	7,196	.087
SJM6T	SJML6T	.3750	1.025	.500	.416	.687	1.938	3/8-24	1.187	11	8,580	.136
SJM7T	SJML7T	.4375	1.150	.562	.452	.781	2.125	7/16-20	1.281	13	12,000	.183
SJM8T	SJML8T	.5000	1.337	.625	.515	.875	2.438	1/2-20	1.468	11	19,520	.278
SJM10T	SJML10T	.6250	1.525	.750	.577	1.062	2.625	5/8-18	1.562	14	21,920	.424
SJM12T	SJML12T	.7500	1.775	.875	.640	1.250	2.875	3/4-16	1.687	17	29,310	.639

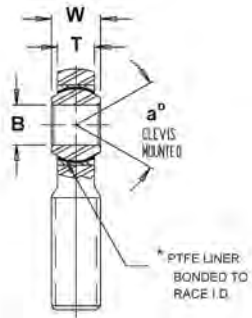
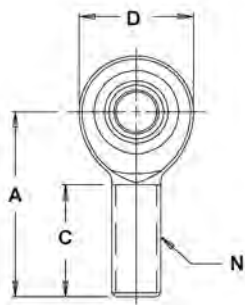

MATERIALS

BALL	BODY
440C CRES STAINLESS STEEL HEAT TREATED	17-4PH CRES STAINLESS STEEL HEAT TREATED
RACE	LINER
17-4PH CRES STAINLESS STEEL HEAT TREATED	*TEFLON FABRIC

SRSM-T - STAINLESS STEEL - EXTRA HEAVY DUTY SHANK

MALE ROD ENDS		B DIA.	D DIA.	W WIDTH	T WIDTH	BALL DIA.	A LGTH	N THD.	C LGTH	a° MIS. ANGLE	ULT. STATIC RADIAL LOAD (lbs.)	APPROX. WEIGHT (lbs.)
RIGHT HAND PART NO.	LEFT HAND PART NO.	+.0000 -.0005	+.010 -.010	+.000 -.002	+.005 -.005	REF.	+.010 -.010	UNF 3A	+.031 -.031	REF.		
SRSM6T	SRSML6T	.3750	1.150	.500	.416	.687	2.125	7/16-20	1.375	11	17,610	.160
SRSM7T	SRSML7T	.4375	1.337	.562	.452	.781	2.438	1/2-20	1.500	13	23,470	.249
SRSM8T	SRSML8T	.5000	1.525	.625	.515	.875	2.625	5/8-18	1.625	11	33,172	.382
SRSM10T	SRSML10T	.6250	1.775	.750	.577	1.062	2.875	3/4-16	1.750	14	40,507	.602

* A TRADE MARK OF E.I. DUPONT DE NEMOURS & CO., INC.



SJF-T / SJFL-T

3-PIECE, PRECISION - STAINLESS STEEL, WEAR RESISTANT, SELF-LUBRICATING

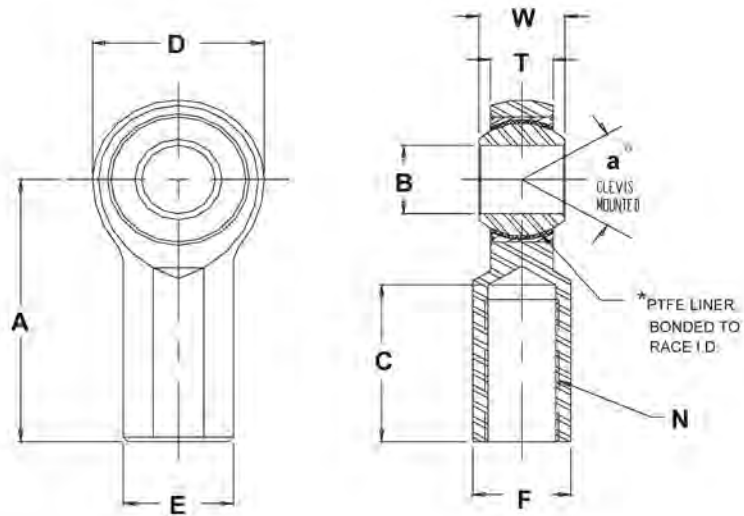

FEMALE ROD ENDS		B DIA.	D DIA.	W WIDTH	T WIDTH	BALL DIA.	A LGTH	N THD.	C LGTH	E DIA.	F FLAT	a° MIS. ANGLE	ULT. STATIC RADIAL LOAD (lbs.)	APPROX. WEIGHT (lbs.)
RIGHT HAND PART NO.	LEFT HAND PART NO.	+0.0015 -0.0005	+0.010 -0.010	+0.000 -0.005	+0.005 -0.005	REF.	+0.015 -0.015	UNF 2B	+0.062 -0.031	+0.010 -0.010	+0.010 -0.010	REF.		
SJF4T	SJFL4T	.2500	.806	.375	.281	.500	1.312	1/4-28	.750	.469	.375	16	4,795	.059
SJF5T	SJFL5T	.3125	.900	.437	.344	.625	1.375	5/16-24	.750	.500	.437	14	5,929	.092
SJF6T	SJFL6T	.3750	1.025	.500	.406	.719	1.625	3/8-24	.937	.687	.562	12	7,363	.152
SJF7T	SJFL7T	.4375	1.150	.562	.437	.812	1.812	7/16-20	1.062	.750	.625	14	7,934	.198
SJF8T	SJFL8T	.5000	1.337	.625	.500	.937	2.125	1/2-20	1.187	.875	.750	12	12,527	.329
SJF10T	SJFL10T	.6250	1.525	.750	.562	1.125	2.500	5/8-18	1.500	1.000	.875	16	13,851	.477
SJF12T	SJFL12T	.7500	1.775	.875	.687	1.312	2.875	3/4-16	1.750	1.125	1.000	14	21,664	.723

* A TRADE MARK OF E.I. DUPONT DE NEMOURS & CO., INC.

MATERIALS

BALL	BODY
440C CRES STAINLESS STEEL HEAT TREATED	17-4PH CRES STAINLESS STEEL HEAT TREATED
RACE	LINER
17-4PH CRES STAINLESS STEEL HEAT TREATED	*TEFLON FABRIC



HRSMX-T / HIN-T

HIGH MISALIGNMENT SERIES - MALE ROD ENDS AND SPHERICAL BEARINGS - HEAVY DUTY

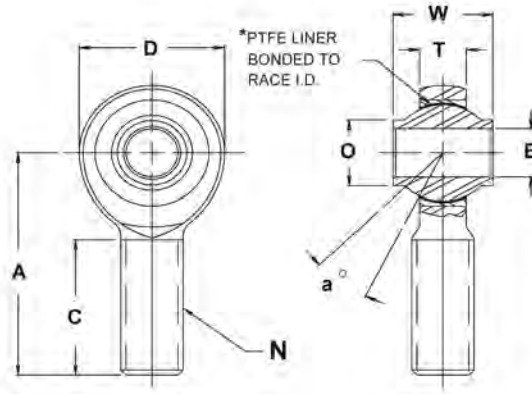

MALE ROD ENDS		B DIA.	D DIA.	W WIDTH	T WIDTH	BALL DIA.	A LGTH	N THD.	C LGTH	O DIA.	a° MIS. ANGLE	ULT. STATIC RADIAL LOAD (lbs.)	APPROX. WEIGHT (lbs.)
RIGHT HAND PART NO.	LEFT HAND PART NO.	+ .0000 - .0005	+ .010 - .010	+ .000 - .005	+ .005 - .005	REF.	+ .015 - .015	UNF 3A	+ .031 - .031	REF.	REF.		
HRSMX6T	HRSMXL6T	.3750	1.150	.813	.355	.781	2.125	7/16-20	1.281	.512	22	11,789	.15
HRSMX7T	HRSMXL7T	.4375	1.337	.875	.355	.875	2.438	1/2-20	1.468	.618	21	17,100	.24
HRSMX8T	HRSMXL8T	.5000	1.525	.937	.411	1.000	2.625	5/8-18	1.562	.730	19	23,703	.39
HRSMX10T	HRSMXL10T	.6250	1.775	1.200	.577	1.250	2.875	3/4-16	1.687	.856	19	32,100	.60
HRSMX12T	HRSMXL12T	.7500	2.025	1.280	.630	1.375	3.375	7/8-14	2.000	.970	18	38,701	.89

MATERIALS

BALL	BODY
52100 STEEL Rc 56 MIN. HARDNESS HARD CHROME PLATED	4340 STEEL, HEAT TREATED ZINC PLATED CHROMATE TREATED
RACE	LINER
STEEL ALLOY ZINC PLATED CHROMATE TREATED	*TEFLON FABRIC

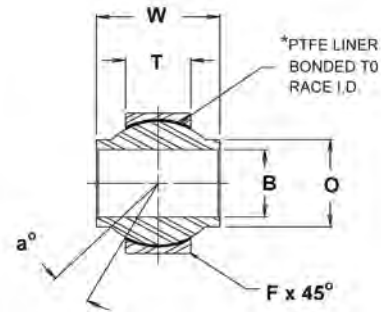
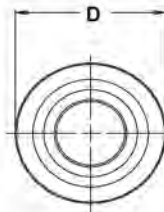

* A TRADE MARK OF E.I. DUPONT DE NEMOURS & CO., INC.

BEARING PART NO.	B DIA.	D DIA.	W WIDTH	T WIDTH	O DIA.	BALL DIA.	F CHAMFER ANGLE	a° MIS. RADIAL	ULT. STATIC WEIGHT LOAD (lbs.)	APPROX. (lbs.)
	+ .0000 - .0005	+ .0000 - .0005	+ .000 - .005	+ .005 - .005	REF.	REF.	REF.	REF.		
HIN6T	.3750	.9060	.813	.345	.512	.781	.030	23	16,983	.068
HIN7T	.4375	1.0000	.875	.345	.618	.875	.030	22	19,023	.095
HIN8T	.5000	1.1250	.937	.401	.730	1.000	.030	20	25,275	.160
HIN10T	.6250	1.3750	1.200	.567	.856	1.250	.030	20	44,652	.245
HIN12T	.7500	1.5625	1.280	.620	.970	1.375	.035	18	53,716	.315

HJMX-T / HJMXL-T

HIGH MISALIGNMENT SERIES - MALE ROD ENDS - HEAVY DUTY, SELF-LUBRICATING

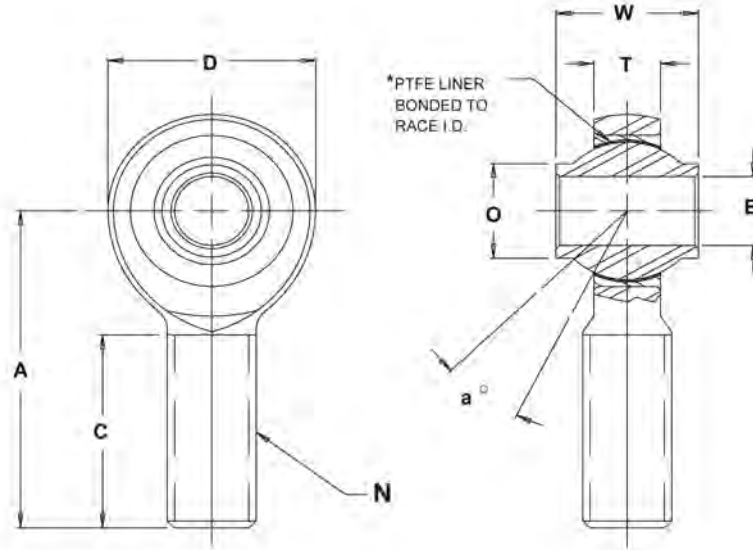

MALE ROD ENDS		B DIA.	D DIA.	W WIDTH	T WIDTH	BALL DIA.	A LGTH	N THD.	C LGTH	O DIA.	a° MIS. ANGLE	ULT. STATIC RADIAL LOAD (lbs.)	APPROX. WEIGHT (lbs.)
RIGHT HAND PART NO.	LEFT HAND PART NO.	+.0000 -.0005	+.010 -.010	+.000 -.005	+.005 -.005	REF.	+.015 -.015	UNF 3A	+.031 -.031	REF.	REF.		
HJMX6T	HJMXL6T	.3750	1.150	.813	.355	.781	2.125	3/8-24	1.281	.512	22	11,390	.12
HJMX7T	HJMXL7T	.4375	1.337	.875	.355	.875	2.438	7/16-20	1.468	.618	21	15,716	.23
HJMX8T	HJMXL8T	.5000	1.525	.937	.411	1.000	2.625	1/2-20	1.562	.730	19	23,703	.33
HJMX10T	HJMXL10T	.6250	1.775	1.200	.577	1.250	2.875	5/8-18	1.687	.856	19	28,109	.57
HJMX12T	HJMXL12T	.7500	2.025	1.280	.630	1.375	3.375	3/4-16	2.000	.970	18	38,701	.82

MATERIALS

BALL	BODY
52100 STEEL Rc 56 MIN. HARDNESS HARD CHROME PLATED	4340 STEEL, HEAT TREATED ZINC PLATED CHROMATE TREATED
RACE	LINER
STEEL ALLOY ZINC PLATED CHROMATE TREATED	*TEFLON FABRIC

* A TRADE MARK OF E.I. DUPONT DE NEMOURS & CO., INC.



PMX-T / PMXL-T

3-PIECE PERFORMANCE RACING, STAINLESS STEEL RACE, WEAR RESISTANT, SELF-LUBRICATING

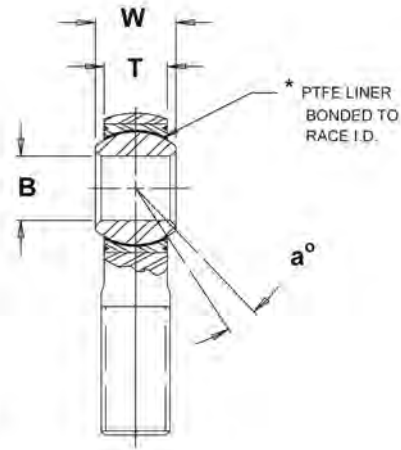
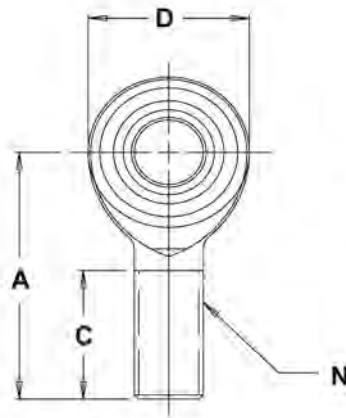

MALE ROD ENDS		B DIA.	D DIA.	W WIDTH	T WIDTH	BALL DIA.	A LGTH	N THD.	C LGTH	a° MIS. ANGLE	ULT. STATIC RADIAL LOAD (lbs.)	APPROX. WEIGHT (lbs.)
RIGHT HAND PART NO.	LEFT HAND PART NO.	+ .0015 - .0005	+ .010 - .010	+ .000 - .005	+ .005 - .005	REF.	+ .010 - .010	UNF 3A	+ .031 - .031	REF.		
PMX5T	PMXL5T	.3125	.900	.437	.327	.593	1.875	5/16-24	1.187	14	8,302	.08
PMX6T	PMXL6T	.3750	1.025	.500	.416	.687	1.938	3/8-24	1.187	8	10,940	.13
PMX7T	PMXL7T	.4375	1.150	.562	.452	.781	2.125	7/16-20	1.281	10	14,052	.18
PMX8T	PMXL8T	.5000	1.337	.625	.515	.875	2.438	1/2-20	1.468	9	23,314	.27
PMX10T	PMXL10T	.6250	1.525	.750	.577	1.062	2.625	5/8-18	1.562	12	25,900	.42
PMX12T	PMXL12T	.7500	1.775	.875	.640	1.250	2.875	3/4-16	1.687	13	34,322	.63

MATERIALS

BALL	BODY
440C STAINLESS STEEL OR 52100 STEEL HEAT TREATED R/C 56 MIN. HARD CHROME PLATED MANUFACTURER'S OPTION	4340 STEEL HEAT TREATED ZINC PLATED CHROMATE TREATED
RACE	LINER
17-4PH CRES STAINLESS STEEL HEAT TREATED	*TEFLON FABRIC

* A TRADE MARK OF E.I. DUPONT DE NEMOURS & CO., INC.



EMX

3-PIECE, PRECISION - EXTRA CAPACITY / PTFE LINERS AVAILABLE

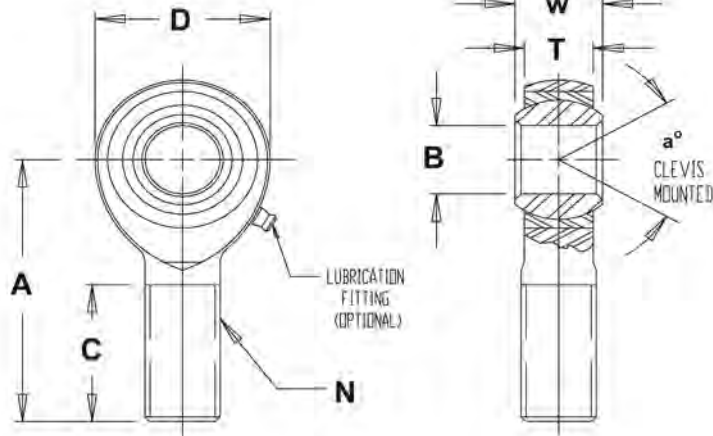

MALE ROD ENDS		B DIA.	D DIA.	W WIDTH	T WIDTH	BALL DIA.	A LGTH	N THD.	C LGTH	a° MIS. ANGLE	ULT. STATIC RADIAL LOAD (lbs.)		APPROX. WEIGHT (lbs.)
RIGHT HAND PART NO.	LEFT HAND PART NO.	+ .0015 - .0005	+ .010 - .010	+ .000 - .005	+ .005 - .005	REF.	+ .015 - .015	UNF 3A	+ .062 - .031	REF.	WITH LUBE	WITHOUT LUBE	
EMX4	EMXL4	.2500	.750	.375	.281	.500	1.562	5/16-24	1.000	16	3,260	6,680	.06
EMX5	EMXL5	.3125	.875	.437	.344	.625	1.875	3/8-24	1.250	14	4,920	8,410	.09
EMX6	EMXL6	.3750	1.000	.500	.406	.719	1.938	7/16-20	1.250	12	7,240	11,160	.13
EMX7	EMXL7	.4375	1.125	.562	.437	.812	2.125	1/2-20	1.375	14	7,620	13,660	.18
EMX8	EMXL8	.5000	1.312	.625	.500	.937	2.438	5/8-18	1.500	12	11,920	19,340	.30
EMX10	EMXL10	.6250	1.500	.750	.562	1.125	2.625	3/4-16	1.625	16	13,940	21,080	.46
EMX12	EMXL12	.7500	1.750	.875	.687	1.312	2.875	7/8-14	1.750	14	21,570	29,800	.72

MATERIALS

BALL	BODY
52100 STEEL	ALLOY STEEL, HEAT TREATED, ZINC PLATED
Rc 56 MIN. HARDNESS	TREATED, ZINC PLATED
HARD CHROME PLATED	CHROMATE TREATED
RACE	
STEEL ALLOY, HEAT TREATED	
ZINC PLATED, CHROMATE TREATED	

NOTES:

FOR GREASE FITTINGS ADD "Z" TO SUFFIX. **EXAMPLE:** EMX6Z

FOR STUDS ADD "Y" TO SUFFIX. **EXAMPLE:** EMX5Y

FOR TEFLON LINER ADD "T" TO SUFFIX. **EXAMPLE:** EMX12T



ALJM / ALJML

3-PIECE, MALE ALUMINUM SERIES / PTFE LINERS AVAILABLE

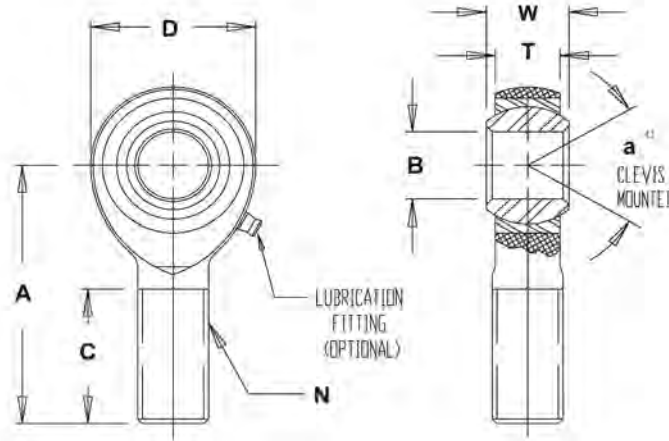

MALE ROD ENDS		B DIA.	D DIA.	W WIDTH	T WIDTH	BALL DIA.	A LGTH	N THD.	C LGTH	a° MIS. ANGLE	ULT. STATIC RADIAL LOAD (lbs.)	APPROX. WEIGHT (lbs.)
RIGHT HAND PART NO.	LEFT HAND PART NO.	+0.0015 -0.0005	+0.010 -0.010	+0.000 -0.005	+0.005 -0.005	REF.	+0.015 -0.015	UNF 3A	+0.062 -0.031	REF.		
ALJM3	ALJML3	.1900	.625	.312	.250	.437	1.250	10-32	.750	13	1,360	.022
ALJM4	ALJML4	.2500	.750	.375	.281	.500	1.562	1/4-28	1.000	16	2,465	.034
ALJM5	ALJML5	.3125	.875	.437	.344	.625	1.875	5/16-24	1.250	14	2,850	.050
ALJM6	ALJML6	.3750	1.000	.500	.406	.719	1.938	3/8-24	1.250	12	4,208	.078
ALJM7	ALJML7	.4375	1.125	.562	.437	.812	2.125	7/16-20	1.375	14	4,534	.091
ALJM8	ALJML8	.5000	1.312	.625	.500	.937	2.438	1/2-20	1.500	12	7,698	.140
ALJM8H	ALJML8H	.5000	1.500	.625	.500	.937	2.625	1/2-20	1.562	12	10,150	.140
ALJM10	ALJML10	.6250	1.500	.750	.562	1.125	2.625	5/8-18	1.625	16	8,516	.240
ALJM10H	ALJML10H	.6250	1.750	.750	.562	1.125	2.625	5/8-18	1.625	16	16,200	.268
ALJM12	ALJML12	.7500	1.750	.875	.687	1.312	2.875	3/4-16	1.750	14	13,319	.300
ALJM12H	ALJML12H	.7500	2.000	.875	.687	1.312	3.000	3/4-16	1.750	14	23,390	.300

MATERIALS

BALL	BODY
52100 STEEL	ALUMINUM
Rc 56 MIN. HARDNESS	7075-T6
HARD CHROME PLATED	HARD ANODIZED RED
RACE	
STEEL ALLOY, HEAT TREATED	
ZINC PLATED, CHROMATE TREATED	

NOTES:

FOR STUDS ADD "Y" TO SUFFIX. **EXAMPLE:** ALJM4Y

FOR TEFLON LINER ADD "T" TO SUFFIX. **EXAMPLE:** ALJM5T

FOR GREASE FITTINGS ADD "Z" TO SUFFIX. **EXAMPLE:** ALJM6Z



ALJF / ALJFL

3-PIECE, ALUMINUM SERIES / PTFE LINERS AVAILABLE

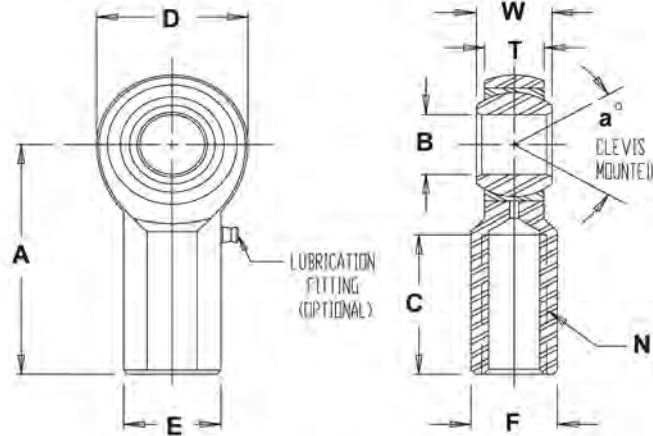

FEMALE ROD ENDS		B DIA.	D DIA.	W WIDTH	T WIDTH	BALL DIA.	A LGTH	N THD.	C LGTH	E DIA.	F FLAT	a° MIS. ANGLE	ULT. STATIC RADIAL LOAD (lbs.)	APPROX. WEIGHT (lbs.)
RIGHT HAND PART NO.	LEFT HAND PART NO.	+.0015 -.0005	+.010 -.010	+.000 -.005	+.005 -.005	REF.	+.015 -.015	UNF 2B	+.062 -.031	+.010 -.010	+.010 -.010	REF.		
ALJF3	ALJFL3	.1900	.625	.312	.250	.437	1.062	10-32	.500	.406	.312	13	1,360	.022
ALJF4	ALJFL4	.2500	.750	.375	.281	.500	1.312	1/4-28	.687	.469	.375	16	2,592	.034
ALJF5	ALJFL5	.3125	.875	.437	.344	.625	1.375	5/16-24	.687	.500	.437	14	2,890	.050
ALJF6	ALJFL6	.3750	1.000	.500	.406	.719	1.625	3/8-24	.812	.687	.562	12	3,952	.088
ALJF8	ALJFL8	.5000	1.312	.625	.500	.937	2.125	1/2-20	1.062	.875	.750	12	7,006	.186

MATERIALS

BALL	BODY
52100 STEEL	ALUMINUM
Rc 56 MIN. HARDNESS	7075-T6
HARD CHROME PLATED	HARD ANODIZED RED
RACE	
STEEL ALLOY, HEAT TREATED	
ZINC PLATED, CHROMATE TREATED	

NOTES:

FOR STUDS ADD "Y" TO SUFFIX. **EXAMPLE:** ALJF5Y

FOR TEFLON LINER ADD "T" TO SUFFIX. **EXAMPLE:** ALJF4T

FOR GREASE FITTINGS ADD "Z" TO SUFFIX. **EXAMPLE:** ALJF6Z



ALRSM / ALRSM1

3-PIECE, ALUMINUM SERIES / EXTRA STRENGTH - HEAVY DUTY SHANK / PTFE LINERS AVAILABLE

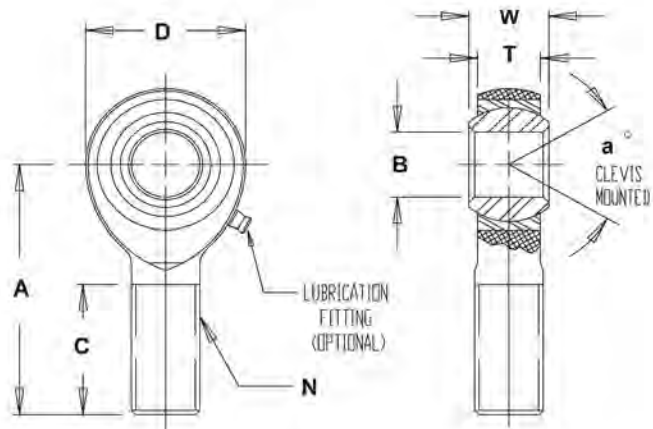

MALE ROD ENDS		B DIA.	D DIA.	W WIDTH	T WIDTH	BALL DIA.	A LGTH	N THD.	C LGTH	a° MIS. ANGLE	ULT. STATIC RADIAL LOAD (lbs.)	APPROX. WEIGHT (lbs.)
RIGHT HAND PART NO.	LEFT HAND PART NO.	+.0015 -.0005	+.010 -.010	+.000 -.005	+.005 -.005	REF.	+.015 -.015	UNF 3A	+.062 -.031	REF.		
ALRSM6	ALRSM16	.3750	1.125	.500	.406	.719	2.125	7/16-20	1.375	10	7,718	.088
ALRSM7	ALRSM17	.4375	1.312	.562	.437	.812	2.438	1/2-20	1.500	12	11,000	.121
ALRSM8	ALRSM18	.5000	1.500	.625	.500	.937	2.625	5/8-18	1.625	10	14,880	.200
ALRSM10	ALRSM10	.6250	1.750	.750	.562	1.125	2.875	3/4-16	1.750	13	19,240	.317
ALRSM10-8	ALRSM10-8	.5000	1.750	.750	.562	1.125	2.875	3/4-16	1.750	13	19,240	.317

MATERIALS

BALL	BODY
52100 STEEL Rc 56 MIN. HARDNESS HARD CHROME PLATED	ALUMINUM 7075-T6 HARD ANODIZED RED
RACE	
STEEL ALLOY, HEAT TREATED ZINC PLATED, CHROMATE TREATED	

NOTES:

FOR GREASE FITTINGS ADD "Z" TO SUFFIX. **EXAMPLE:** ALRSM6Z
FOR TEFLON LINER ADD "T" TO SUFFIX. **EXAMPLE:** ALRSM8T



B

BALL JOINTS, SWAGED CONSTRUCTION WITH DIRT SHIELD

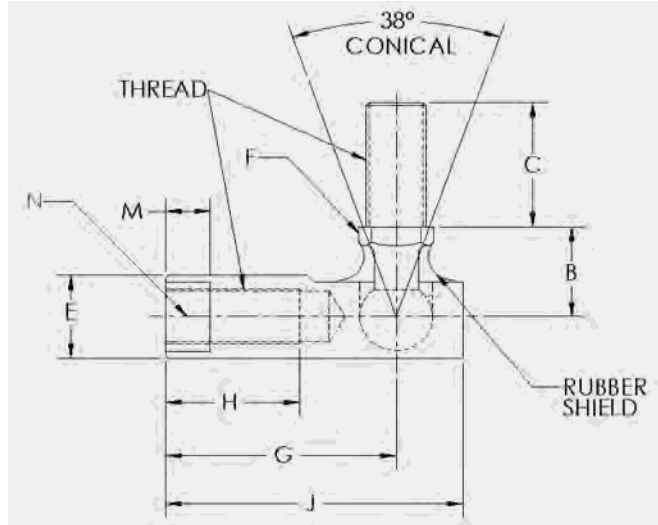

PART NUMBER	THREAD	B	C	E	F	G	H	J	M	N	TENSILE & SHEAR STRENGTH (lbs.)	FORCE TO REMOVE STUD (lbs.)
B3	10-32	.438	.438	.375	.313	.875	.438	1.063	.218	.312	300	500
B4	1/4-28	.469	.563	.438	.375	.969	.500	1.219	.281	.375	850	837
B5	5/16-24	.531	.688	.500	.438	1.125	.563	1.406	.281	.438	1,500	1,000
B6	3/8-24	.688	.875	.625	.500	1.375	.750	1.688	.313	.500	2,400	1,512
B7	7/16-20	.875	1.125	.750	.625	1.938	1.000	2.375	.375	.625	2,700	2,173
B8	1/2-20	.875	1.125	.750	.625	1.938	1.000	2.375	.375	.625	2,700	2,400
B10	5/8-18	1.000	1.125	.875	.750	2.063	1.000	2.578	.500	.750	2,950	3,150

MATERIALS

BODY	BALL STUD
LOW CARBON STEEL	LOW CARBON STEEL
ZINC PLATED	HEAT TREATED
DICHROMATE TREATED	ZINC PLATED, DICHROMATE TREATED

NOTES:

1. BALL CAVITY IS PRE-LOADED WITH HIGH IMPACT LUBRICANT.
2. THESE BALL JOINTS ARE SUPPLIED WITH A DIRT SHIELD FOR PROTECTION AGAINST CONTAMINANTS.

ADJUSTER LADDER

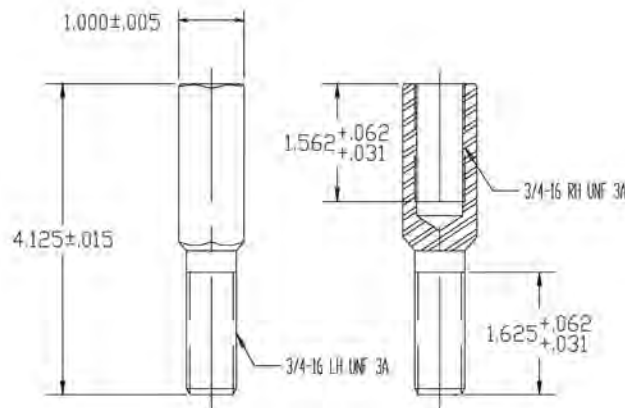

MATERIALS

LOW CARBON STEEL - ZINC PLATED



COM / COMH

COMMERCIAL SERIES / PTFE LINERS AVAILABLE

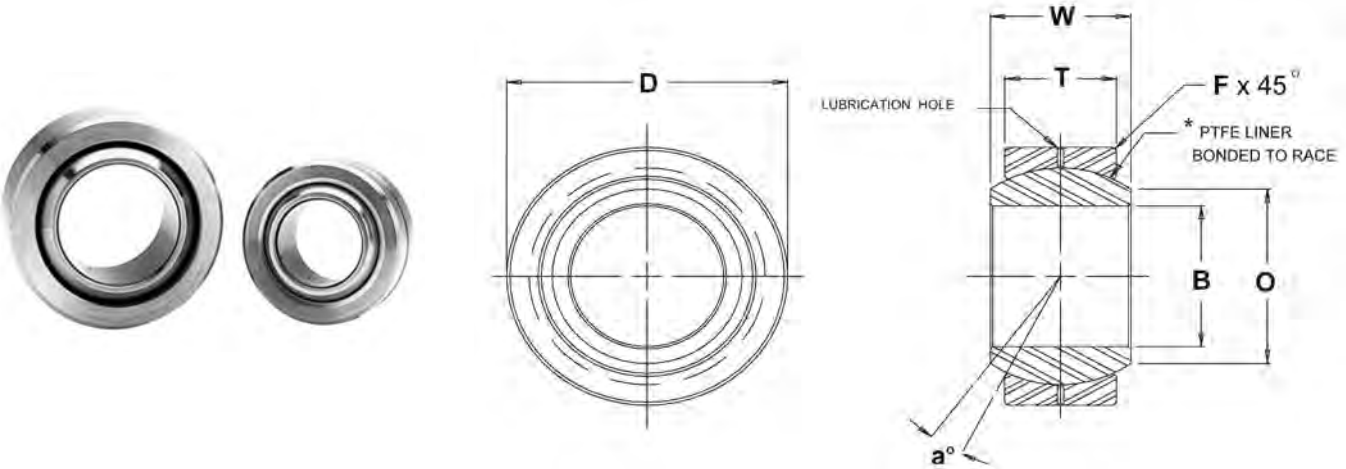

BEARING PART NO.	B DIA.	D DIA.	W WIDTH	T WIDTH	O DIA.	BALL DIA.	F CHAMFER ANGLE	a° MIS. RADIAL	ULT. STATIC WEIGHT LOAD (lbs.)	APPROX. (lbs.)
	+ .0015 - .0005	+ .0000 - .0007	+ .005 - .005	+ .005 - .005	REF.	REF.	REF.	REF.		
COM3	.1900	.5625	.281	.218	.293	.406	.015	11	3,250	.014
COM4	.2500	.6562	.343	.250	.364	.500	.022	13.5	4,950	.022
COM5	.3125	.7500	.375	.281	.419	.562	.032	12	6,475	.030
COM6	.3750	.8125	.406	.312	.516	.656	.032	10	8,400	.038
COM7	.4375	.9062	.437	.343	.530	.687	.032	8	9,453	.047
COM8	.5000	1.0000	.500	.390	.600	.781	.032	9.5	13,250	.065
COM8-101	.5000	1.0000	1.000	.390	.600	.781	.032	9.5	13,250	.065
COM9	.5625	1.0937	.562	.437	.671	.875	.032	9.5	16,630	.086
COM10	.6250	1.1875	.625	.500	.739	.968	.032	8.5	21,280	.110
COM12	.7500	1.4375	.750	.593	.920	1.187	.044	9	31,920	.204
COM12T-3R**	.7500	1.4375	.750	.593	.920	1.187	.044	9	31,920	.204
COM14	.8750	1.5625	.875	.703	.980	1.312	.044	9.5	41,960	.263
COM16	1.0000	1.7500	1.000	.797	1.118	1.500	.044	10	55,200	.386
COMH16***	1.0000	2.0000	1.000	.781	1.360	1.687	.032	9	70,820	.553
COMH19***	1.1875	2.3750	1.187	.937	1.610	2.000	.032	8.5	100,730	.895
COMH20***	1.2500	2.3750	1.187	.937	1.610	2.000	.032	8.5	100,730	.895
COMH24***	1.5000	2.7500	1.375	1.094	1.860	2.312	.032	8.5	135,950	1.358
COMH28***	1.7500	3.1250	1.562	1.250	2.110	2.625	.044	8	176,370	1.948
COMH32***	2.0000	3.5000	1.750	1.375	2.360	2.937	.044	8.5	217,060	2.650

* A TRADE MARK OF E.I. DUPONT DE NEMOURS & CO., INC.

** BEARING COMES STANDARD WITH SNAP RING AND TEFLON LINER. CONTACT ENGINEERING FOR FURTHER INFORMATION.

***BORE TOLERANCE: +.0025
-.0005

MATERIALS

BODY	RACE
52100 STEEL	LOW CARBON STEEL
HEAT TREATED	OIL COATED
HARD CHROME PLATED	

NOTES:

- LUBRICATION GROOVES IN I.D. & O.D. OF RACE
- FOR *TEFLON LINER ADD "T" TO SUFFIX. **EXAMPLE:** COM12T
(UNITS WITH *TEFLON LINERS HAVE NO LUBRICATION HOLES OR GROOVES IN RACE.)



FKS / FKS-T

HEAVY DUTY PRECISION SERIES, ALLOY STEEL / PTFE LINERS AVAILABLE

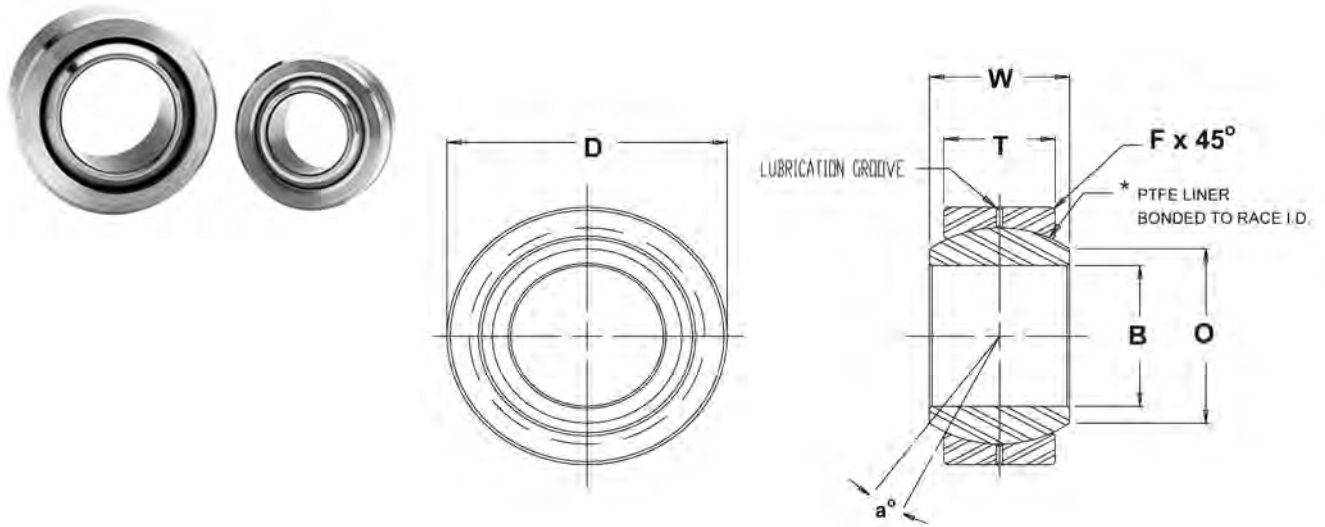

BEARING PART NO.	B DIA.	D DIA.	W WIDTH	T WIDTH	O DIA.	BALL DIA.	F CHAMFER ANGLE	a° MIS. RADIAL	ULT. STATIC WEIGHT LOAD (lbs.)	APPROX. (lbs.)
	+0.0015 -0.0005	+0.0000 -0.0005	+0.005 -0.005	+0.005 -0.005	REF.	REF.	REF.	REF.		
FKS3	.1900	.5625	.281	.218	.293	.406	.015	11	5,400	.014
FKS4	.2500	.6562	.343	.250	.364	.500	.022	13.5	8,400	.022
FKS5	.3125	.7500	.375	.281	.419	.562	.032	12	11,600	.065
FKS6	.3750	.8125	.406	.312	.516	.656	.032	10	15,600	.038
FKS7	.4375	.9062	.437	.343	.530	.687	.032	8	22,300	.047
FKS8	.5000	1.0000	.500	.390	.600	.781	.032	9.5	26,900	.065
FKS9	.5625	1.0937	.562	.437	.671	.875	.032	9.5	36,000	.086
FKS10	.6250	1.1875	.625	.500	.739	.968	.032	8.5	40,000	.110
FKS12	.7500	1.4375	.750	.593	.920	1.187	.044	9	78,000	.204
FKS14	.8750	1.5625	.875	.703	.980	1.312	.044	9.5	86,000	.263
FKS16	1.0000	1.7500	1.000	.797	1.118	1.500	.044	10	104,000	.386

* A TRADE MARK OF E.I. DUPONT DE NEMOURS & CO., INC.

MATERIALS

BALL	RACE
52100 STEEL	ALLOY STEEL
HEAT TREATED	HEAT TREATED
HARD CHROME PLATED	OIL COATED

NOTES:

- LUBRICATION GROOVES IN I.D. & O.D. OF RACE
- FOR *TEFLON LINER ADD "T" TO SUFFIX. **EXAMPLE:** FKS8T
(UNITS WITH *TEFLON LINERS HAVE NO LUBRICATION HOLES OR GROOVES IN RACE.)



FKSSX-T / FKSSX-TV / PFKSSX-T

PRECISION SERIES, PTFE LINED

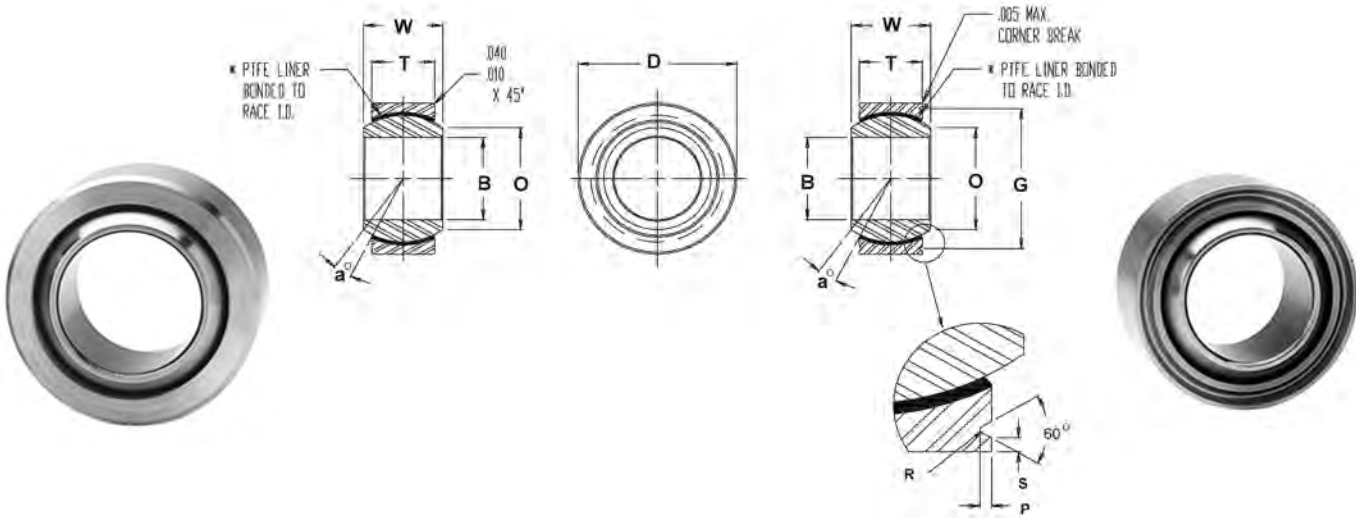

BEARING PART NO.		B DIA.	D DIA.	W WIDTH	T WIDTH	O DIA.	G DIA.	BALL DIA.	a° MIS. ANGLE	LOAD RATINGS (lbs.)			APPROX. WEIGHT (lbs.)
PLAIN	GROOVED									RADIAL (lbs.)	AXIAL (lbs.)	OSIL-LATING LOAD (lbs.)	
FKSSX3T	FKSSX3TV	.1900	.5625	.281	.218	.293	.500	.406	11	3,975	150	1,500	.020
FKSSX4T	FKSSX4TV	.2500	.6562	.343	.250	.364	.594	.500	13.5	6,040	430	3,320	.020
FKSSX5T	FKSSX5TV	.3125	.7500	.375	.281	.419	.650	.562	12	8,750	700	5,460	.030
FKSSX6T	FKSSX6TV	.3750	.8125	.406	.312	.516	.712	.656	10	10,540	1,100	6,600	.040
FKSSX7T	FKSSX7TV	.4375	.9062	.437	.343	.530	.806	.687	9.5	13,200	1,400	8,050	.050
FKSSX8T	FKSSX8TV	.5000	1.0000	.500	.390	.600	.876	.781	9.5	17,900	2,100	10,400	.070
FKSSX9T	FKSSX9TV	.5625	1.0937	.562	.437	.671	.970	.875	9.5	23,200	3,680	13,000	.090
FKSSX10T	FKSSX10TV	.6250	1.1875	.625	.500	.739	1.063	.968	8.5	30,500	4,720	16,450	.120
FKSSX12T	FKSSX12TV	.7500	1.4375	.750	.593	.920	1.313	1.187	9	46,400	6,750	23,600	.210
FKSSX14T	FKSSX14TV	.8750	1.5625	.875	.703	.980	1.438	1.312	9.5	62,200	9,350	30,250	.270
FKSSX16T	FKSSX16TV	1.0000	1.7500	1.000	.797	1.118	1.626	1.500	10	82,200	12,160	38,000	.390

NOTES: DIAMETER "B" AND "D" ARE CONCENTRIC WITHIN .005 T.I.R.

MATERIALS

BALL	
FKSSX-T	PFKSSX-T
440C STAINLESS STEEL HEAT TREATED	52100 STEEL HEAT TREATED HARD CHROME PLATED
RACE	
17-4PH STAINLESS STEEL HEAT TREATED	*TEFLON FABRIC

* A TRADE MARK OF E.I. DUPONT DE NEMOURS & CO., INC.

NO LOAD BREAKAWAY TORQUE

BORE SIZES	TORQUE
3 & 4	.25 to 5.0
5 to 12	1.0 to 5.0
14 & 16	2.0 to 8.0

STAKING GROOVE DATA

BORE SIZES	S	R	P
	LAND	RAD.	DEPTH
	MIN.	+.002 -.005	+.000 -.010
3 & 4	.010	.010	.025
5	.020	.010	.035
6 & 7	.020	.015	.035
8 thru 16	.020	.015	.055



WSSX-T / WSSX-TV

WIDE SERIES, PTFE LINED

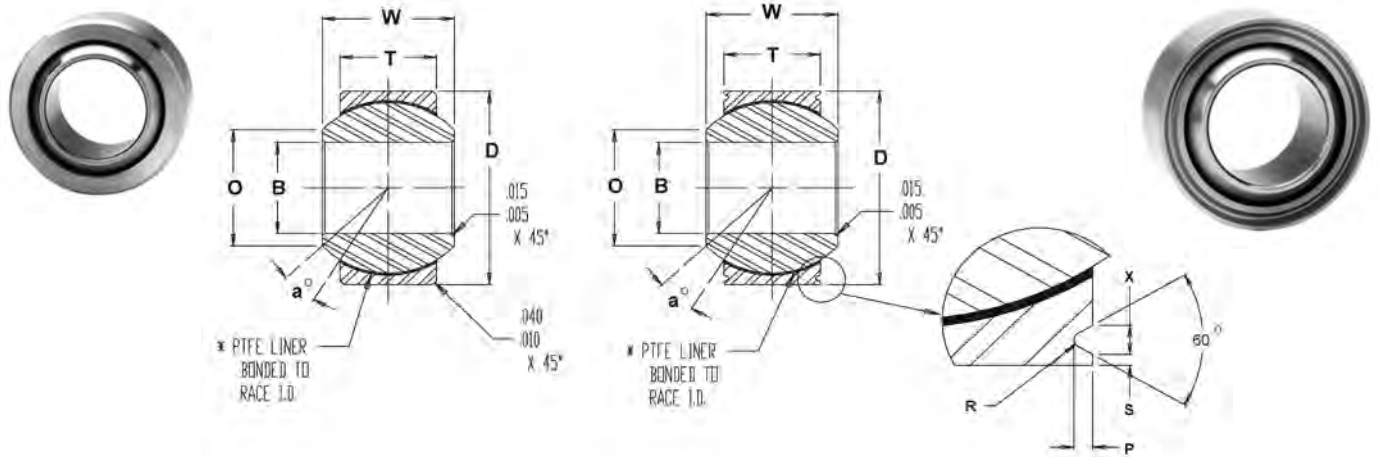

BEARING PART NO.		B DIA.	D DIA.	W WIDTH	T WIDTH	O SHOULDER DIA.	BALL DIA.	a° MIS. ANGLE	LOAD RATINGS (lbs.)			APPROX. WEIGHT (lbs.)
									STATIC LIMIT		DYNAMIC OSCILLATING RADIAL LOAD	
PLAIN	GROOVED	+ .0000 - .0005	+ .0000 - .0005	+ .000 - .002	+ .005 - .005	REF.	REF.	MIN.	RADIAL (lbs.)	AXIAL (lbs.)		
WSSX3T	WSSX3TV	.1900	.6250	.437	.327	.301	.531	15	2,500	1,770	4,900	.031
WSSX4T	WSSX4TV	.2500	.6250	.437	.327	.301	.531	15	5,500	1,770	4,900	.031
WSSX5T	WSSX5TV	.3125	.6875	.437	.317	.360	.593	14	9,400	1,640	6,050	.035
WSSX6T	WSSX6TV	.3750	.8125	.500	.406	.466	.687	8	13,700	2,630	8,310	.060
WSSX7T	WSSX7TV	.4375	.9375	.562	.442	.537	.781	10	20,700	3,650	11,750	.080
WSSX8T	WSSX8TV	.5000	1.0000	.625	.505	.607	.875	9	21,400	4,970	14,950	.100
WSSX9T	WSSX9TV	.5625	1.1250	.687	.536	.721	1.000	10	26,600	5,370	18,100	.135
WSSX10T	WSSX10TV	.6250	1.1875	.750	.567	.747	1.062	12	29,000	6,130	20,250	.160
WSSX12T	WSSX12TV	.7500	1.3750	.875	.630	.845	1.250	13	37,000	7,730	26,200	.240
WSSX14T	WSSX14TV	.8750	1.6250	.875	.755	.995	1.375	6	65,200	10,800	33,600	.350
WSSX16T	WSSX16TV	1.0000	2.1250	1.375	1.005	1.269	1.875	12	104,000	19,300	56,250	.970

NOTES: DIAMETER "B" AND "D" ARE CONCENTRIC WITHIN .005 T.I.R.

MATERIALS

BALL	RACE
440C STAINLESS STEEL HEAT TREATED	17-4PH STAINLESS STEEL HEAT TREATED
LINER	
*TEFLON FABRIC	

* A TRADE MARK OF E.I. DUPONT DE NEMOURS & CO., INC.

NO LOAD BREAKAWAY TORQUE

BORE SIZES	TORQUE
3	.5 to 5.0 in. lbs.
4 thru 12	1.0 to 5.0 in. lbs.
14 & 16	2.0 to 8.0 in. lbs.

STAKING GROOVE DATA

BORE SIZES	S	X	R	P
	LAND	GROOVE	RAD.	DEPTH
	+ .000 - .010	+ .000 - .010	+ .000 - .010	+ .000 - .015
3 thru 5	.020	.045	.015	.030
6 thru 10	.030	.055	.020	.040
12 thru 16	.030	.080	.020	.060



IN-P

PRECISION PLASTIC RACE SERIES, LIGHT DUTY

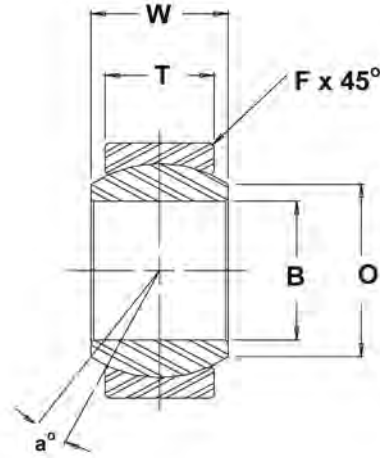
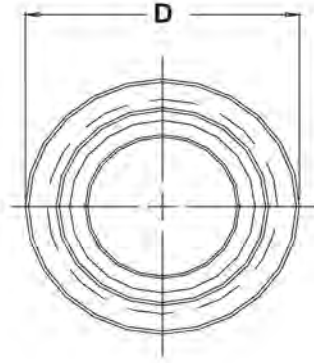

BEARING PART NO.	B DIA.	D DIA.	W WIDTH	T WIDTH	O DIA.	BALL DIA.	F CHAMFER ANGLE	a° MIS. RADIAL	ULT. STATIC WEIGHT LOAD (lbs.)	APPROX. (lbs.)
	+ .0025 - .0005	+ .0000 - .0010	+ .005 - .005	+ .005 - .005	REF.	REF.	REF.	REF.		
IN3P	.1900	.5000	.312	.250	.307	.437	.020	13	939	.010
IN4P	.2500	.5781	.375	.281	.331	.500	.025	16	1,734	.014
IN5P	.3125	.7031	.437	.344	.447	.625	.025	14	2,236	.024
IN6P	.3750	.8125	.500	.406	.516	.718	.030	12	3,209	.036
IN7P	.4375	.9375	.562	.437	.587	.812	.030	14	3,395	.050
IN8P	.5000	1.0625	.625	.500	.699	.937	.030	12	5,360	.074
IN10P	.6250	1.2500	.750	.562	.839	1.125	.030	16	5,920	.122
IN12P	.7500	1.4375	.875	.687	.978	1.312	.035	14	9,240	.188

MATERIALS

BALL	RACE
LOW CARBON STEEL	TEFLON LUBRICATED,
CASE HARDENED	FIBER REINFORCED
ZINC PLATED	ENGINEERING PLASTIC

K SERIES

SPECIAL PURPOSE SERIES

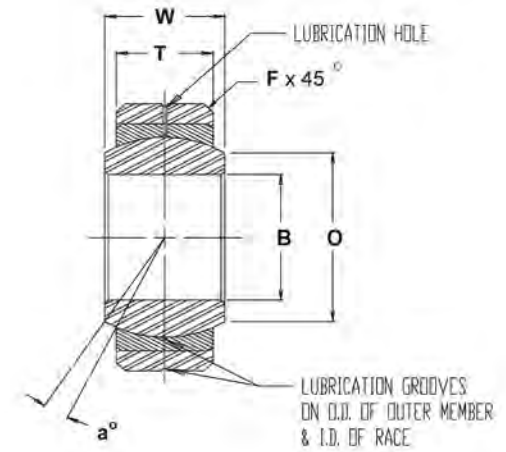
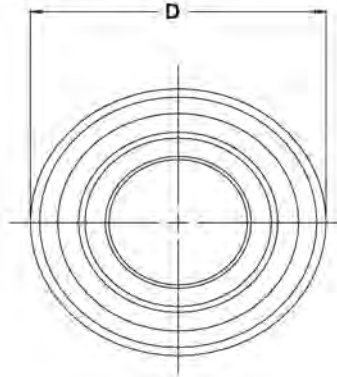

BEARING PART NO.	B DIA.	D DIA.	W WIDTH	*T WIDTH	O DIA.	BALL DIA.	F CHAMFER ANGLE	a° MIS. RADIAL	MAXIMUM STATIC WEIGHT LOAD (lbs.)	APPROX. (lbs.)
	+0.0000 -0.0005	+0.0000 -0.0005	+0.000 -0.005	+0.000 -0.005	REF.	REF.	.015 -0.000	REF.		
K3	.1900	.6250	.281	.187	.293	.406	.016	16.5	2,961	.02
K4	.2500	.7500	.375	.281	.354	.500	.016	14.5	5,246	.04
K5	.3125	.8750	.437	.313	.447	.625	.016	14	6,554	.05
K6	.3750	1.0000	.500	.375	.517	.718	.016	12.5	8,606	.08
K7	.4375	1.1875	.562	.437	.586	.812	.032	11	11,100	.12
K8	.5000	1.3125	.687	.531	.637	.937	.044	12.5	15,600	.18
K10	.6250	1.5625	.875	.687	.802	1.187	.044	12	25,700	.33
K12	.7500	2.2500	1.250	.937	1.038	1.625	.044	15	47,600	.97
K16	1.0000	2.3750	1.125	.875	1.345	1.750	.062	10	48,200	.94
K19	1.1875	2.6250	1.250	1.000	1.562	2.000	.085	8.5	63,000	1.27
K24	1.5000	3.2500	1.500	1.250	2.000	2.500	.085	7	98,000	2.38
K30	1.8750	4.0000	1.625	1.313	2.521	3.000	.125	7	123,500	3.75

* "T" TOLERANCE ACROSS INSERTS IS +/- .015.

MATERIALS

OUTER MEMBER	
LOW-CARBON STEEL	
ZINC PLATED	
CHROMATE TREATED ON ALL SURFACES EXPOSED AFTER INSTALLATION	
RACE	BALL
BRASS OR	52100 STEEL
SINTERED BRONZE	HEAT TREATED
MANUFACTURER'S OPTION	HARD CHROME PLATED



GEZ-ES

INCH - SPHERICAL PLAIN BEARINGS WITH SINGLE FRACTURED RACE

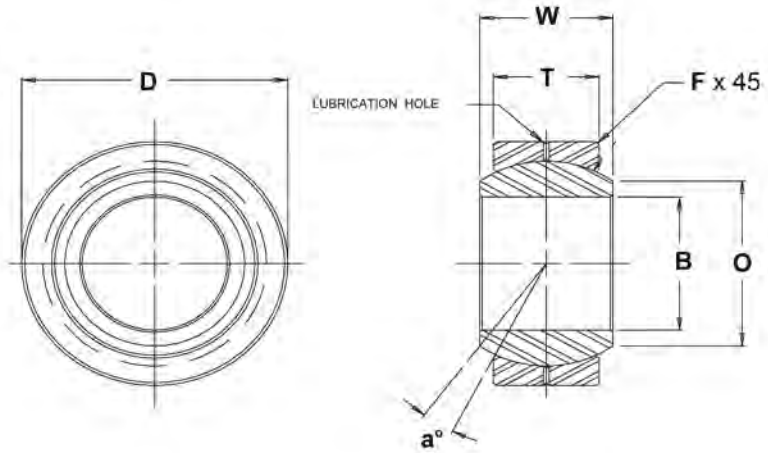

BEARING PART NUMBER		B DIA.		D DIA.		W WIDTH		T WIDTH		O DIA.	F CMFR	a° MIS. ANG.	ULT. STATIC RADIAL LOAD (lbs.)	APPROX. WEIGHT (lbs.)
OPEN	SEALED	MAX.	MIN.	MAX.	MIN.	MAX.	MIN.	MAX.	MIN.	REF.	REF.	REF.		
GEZ8ES	GEZ8ES-2RS	.5000	.4995	.8750	.8745	.437	.432	.375	.365	.555	.024	6	9,217	.049
GEZ10ES	GEZ10ES-2RS	.6250	.6245	1.0625	1.0620	.547	.542	.469	.459	.720	.024	6	14,635	.079
GEZ12ES	GEZ12ES-2RS	.7500	.7495	1.2500	1.2495	.656	.651	.562	.552	.858	.024	6	21,356	.117
GEZ14ES	GEZ14ES-2RS	.8750	.8745	1.4375	1.4370	.765	.760	.656	.646	1.000	.024	6	28,550	.187
GEZ16ES	GEZ16ES-2RS	1.0000	.9995	1.6250	1.6245	.875	.870	.750	.740	1.087	.024	6	37,317	.267
GEZ20ES	GEZ20ES-2RS	1.2500	1.2495	2.0000	1.9995	1.093	1.088	.937	.925	1.417	.024	6	58,448	.512
GEZ22ES	GEZ22ES-2RS	1.3750	1.3745	2.1875	2.1870	1.187	1.182	1.031	1.019	1.515	.039	6	69,688	.773
GEZ24ES	GEZ24ES-2RS	1.5000	1.4995	2.4375	2.4370	1.312	1.307	1.125	1.113	1.622	.039	6	84,300	.930
GEZ28ES	GEZ28ES-2RS	1.7500	1.7495	2.8125	2.8120	1.531	1.526	1.312	1.300	1.996	.039	6	114,648	1.413
GEZ32ES	GEZ32ES-2RS	2.0000	1.9995	3.1875	3.1869	1.750	1.745	1.500	1.484	2.280	.039	6	150,616	2.055
GEZ36ES	GEZ36ES-2RS	2.2500	2.2494	3.5625	3.5619	1.969	1.963	1.687	1.671	2.555	.039	6	191,080	2.932
GEZ40ES	GEZ40ES-2RS	2.5000	2.4994	3.9375	3.9369	2.187	2.181	1.875	1.859	2.886	.039	6	238,288	4.079
GEZ44ES	GEZ44ES-2RS	2.7500	2.7494	4.3750	4.3744	2.406	2.400	2.062	2.046	3.114	.039	6	281,000	5.335
GEZ48ES	GEZ48ES-2RS	3.0000	2.9994	4.7500	4.7493	2.625	2.619	2.250	2.230	3.417	.039	6	337,200	6.834
GEZ52ES	GEZ52ES-2RS	3.2500	3.2492	5.1250	5.1243	2.844	2.836	2.437	2.417	3.720	.039	6	395,648	8.422
GEZ56ES	GEZ56ES-2RS	3.5000	3.4992	5.5000	5.4993	3.062	3.054	2.625	2.605	4.000	.039	6	458,595	10.560
GEZ60ES	GEZ60ES-2RS	3.7500	3.7492	5.8750	5.8743	3.281	3.273	2.812	2.792	4.280	.039	6	530,528	12.743
GEZ64ES	GEZ64ES-2RS	4.0000	3.9992	6.2500	6.2490	3.500	3.492	3.000	2.980	4.559	.039	6	595,720	15.410
GEZ68ES	GEZ68ES-2RS	4.2500	4.2492	6.6250	6.6240	3.719	3.711	3.187	3.167	4.835	.039	6	674,400	18.541
GEZ72ES	GEZ72ES-2RS	4.5000	4.4992	7.0000	6.9990	3.937	3.929	3.375	3.355	5.142	.039	6	764,320	21.583
GEZ76ES	GEZ76ES-2RS	4.7500	4.7490	7.3750	7.3738	4.156	4.148	3.562	3.542	5.417	.039	6	843,000	25.353
GEZ80ES	GEZ80ES-2RS	5.0000	4.9990	7.7500	7.7488	4.375	4.365	3.750	3.730	5.720	.039	6	932,920	29.762
GEZ96ES	GEZ96ES-2RS	6.0000	5.9990	8.7500	8.7488	4.750	4.740	4.125	4.105	6.622	.039	5	1,168,960	38.581

MATERIALS

BALL	RACE
ALLOY STEEL	ALLOY STEEL, HEAT TREATED
HEAT TREATED	SINGLE FRACTURE
PHOSPHATE COATED	PHOSPHATE COATED

NOTES:

- LUBRICATING HOLES AND GROOVES ARE LOCATED ON INNER AND OUTER RACES.
- TYPE 2RS HAS SEALS ON BOTH SIDES.

CHECK AVAILABILITY ON ALL SIZES.



GE-ES

METRIC - SPHERICAL PLAIN BEARINGS WITH SINGLE FRACTURED RACE

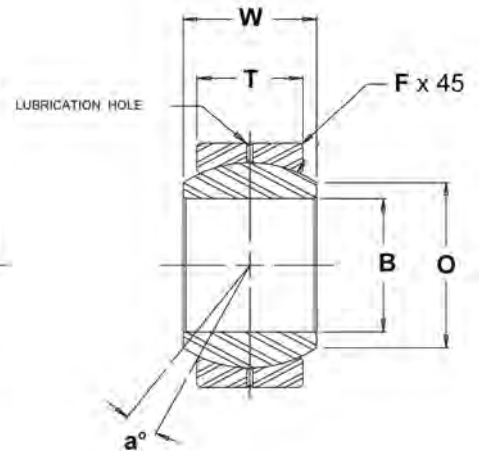
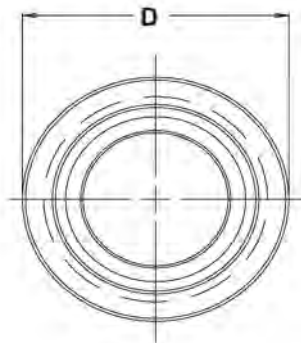

BEARING PART NUMBER		B DIA.		D DIA.		W WIDTH		T WIDTH		O DIA.	F CMFR	a° MIS. ANG.	ULT. STATIC RADIAL LOAD (kN)	APPROX. WEIGHT (kg)
OPEN	SEALED	MAX.	MIN.	MAX.	MIN.	MAX.	MIN.	MAX.	MIN.	REF.	REF.	REF.		
GE12E		12.000	11.992	22.000	21.991	10.00	9.88	7.00	6.76	15	0.3	11	54	.016
GE15ES	GE15ES-2RS	15.000	14.992	26.000	25.991	12.00	11.88	9.00	8.76	18	0.3	8	85	.025
GE17ES	GE17ES-2RS	17.000	16.992	30.000	29.991	14.00	13.88	10.00	9.76	20	0.3	10	106	.041
GE20ES	GE20ES-2RS	20.000	19.990	35.000	34.989	16.00	15.88	12.00	11.76	24	0.3	9	146	.061
GE25ES	GE25ES-2RS	25.000	24.990	42.000	41.989	20.00	19.88	16.00	15.76	29	0.6	7	240	.11
GE30ES	GE30ES-2RS	30.000	29.990	47.000	46.989	22.00	21.88	18.00	17.76	34	0.6	6	310	.14
GE35ES	GE35ES-2RS	35.000	34.988	55.000	54.987	25.00	24.88	20.00	19.70	39	1.0	6	400	.22
GE40ES	GE40ES-2RS	40.000	39.988	62.000	61.987	28.00	27.88	22.00	21.70	45	1.0	7	500	.30
GE45ES	GE45ES-2RS	45.000	44.988	68.000	67.987	32.00	31.88	25.00	24.70	50	1.0	7	640	.40
GE50ES	GE50ES-2RS	50.000	49.988	75.000	74.987	35.00	34.88	28.00	27.70	55	1.0	6	780	.54
GE60ES	GE60ES-2RS	60.000	59.985	90.000	89.985	44.00	43.85	36.00	35.60	66	1.0	6	1,220	1.00
GE70ES	GE70ES-2RS	70.000	69.985	105.000	104.985	49.00	48.85	40.00	39.60	77	1.0	6	1,560	1.50
GE80ES	GE80ES-2RS	80.000	79.985	120.000	119.985	55.00	54.85	45.00	44.60	88	1.0	6	2,000	2.20
GE90ES	GE90ES-2RS	90.000	89.080	130.000	129.982	60.00	59.80	50.00	49.50	98	1.0	5	2,450	2.70
GE100ES	GE100ES-2RS	100.000	99.980	150.000	149.982	70.00	69.80	55.00	54.50	109	1.0	7	3,050	4.30
GE110ES	GE110ES-2RS	110.000	109.980	160.000	159.975	70.00	69.80	55.00	54.50	120	1.0	6	3,250	4.70
GE120ES	GE120ES-2RS	120.000	119.980	180.000	179.975	85.00	84.80	70.00	69.50	130	1.0	6	4,750	8.00
GE140ES	GE140ES-2RS	140.000	139.975	210.000	209.970	90.00	89.75	70.00	69.40	150	1.0	7	5,400	11.00
GE160ES	GE160ES-2RS	160.000	159.975	230.000	229.970	105.00	104.75	80.00	79.40	170	1.0	8	6,800	14.00

MATERIALS

BALL	RACE
ALLOY STEEL	ALLOY STEEL, HEAT TREATED
HEAT TREATED	SINGLE FRACTURE
PHOSPHATE COATED	PHOSPHATE COATED

NOTES:

- LUBRICATING HOLES AND GROOVES ARE LOCATED ON INNER AND OUTER RACES.
- TYPE 2RS HAS SEALS ON BOTH SIDES.

CHECK AVAILABILITY ON ALL SIZES.



-HB

HIGH MISALIGNMENT BUSHINGS

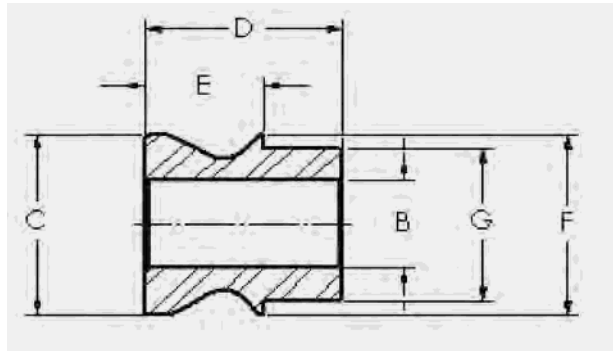

PART NUMBER	B	C	D	E	F SIZE	G	BEARING
8-6HB	.3750	.645	.627	.342	.667	.499	8
10-8HB	.5000	.840	.900	.530	.795	.624	10
12-8HB	.5000	.995	.900	.475	.930	.749	12
12-10HB	.6250	.995	.900	.475	.930	.749	12
14-8HB	.5000	1.040	1.055	.625	1.035	.874	14
14-10HB	.6250	1.050	1.055	.625	1.035	.874	14
16-10HB	.6250	1.245	1.497	.817	1.225	.999	16
16-10HB-2	.6250	1.135	1.370	.690	1.225	.999	16
16-12HB	.7500	1.135	1.370	.690	1.225	.999	16

MATERIAL

17-4PH STAINLESS STEEL

NOTES:

1. ALL DIMENSIONS ARE IN INCHES.
2. MISALIGNMENT BUSHINGS INCREASE MISALIGNMENT ANGLE AND REDUCE HOLE SIZES IN ROD ENDS AND SPHERICAL BEARINGS.
3. ALL BUSHINGS ARE SOLD IN PAIRS.

CENTER FINDERS

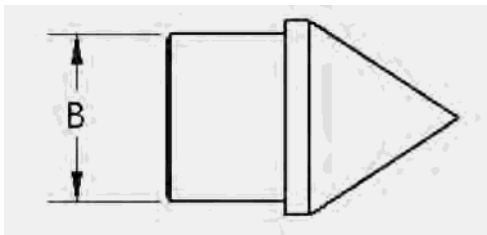

CENTER FINDERS ARE USED TO FIND THE LENGTH BETWEEN TWO CONNECTING RODS FOR EASE OF ASSEMBLY.

PART NUMBER	BEARING SIZE	B
CTR8	8	.500
CTR10	10	.625
CTR12	12	.750
CTR14	14	.875
CTR16	16	1.000

NOTES:

1. CENTER FINDERS ARE SOLD IN PAIRS.
2. TO PURCHASE A COMPLETE PAIR OF EACH SIZE USE PART NUMBER **CTR1**.

STUDED ROD ENDS

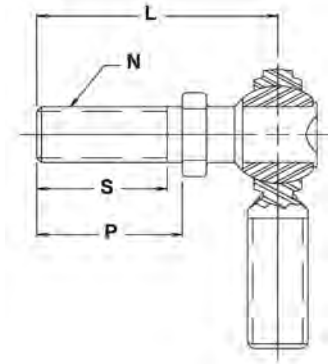

ROD END PART SIZE	L LENGTH	P LENGTH	S LENGTH	N THREAD
	+ .015 - .015	REF.	MIN.	UNF 2A
3	1.016	.500	.437	10-32
4	1.031	.562	.500	1/4-28
5	1.219	.687	.593	5/16-24
6	1.562	.906	.812	3/8-24
7	1.750	1.062	.937	7/16-20
8	2.000	1.125	1.000	1/2-20
10	2.500	1.500	1.375	5/8-18
12	3.000	1.812	1.625	3/4-16

NOTES:

1. AVAILABLE ON ALL SERIES.
2. STUD MATERIAL: LOW CARBON STEEL AND ALLOY STEEL (HEAT TREATED) - ZINC PLATED.
3. STUD MISALIGNMENT APPROX. +/- 25o IN ANY DIRECTION.
4. TO SPECIFY RIGHT HAND STUD, ADD SUFFIX "Y" TO PART NUMBER. **EXAMPLE:** CM6Y
5. TO SPECIFY LEFT HAND STUD, ADD SUFFIX "YL" TO PART NUMBER. **EXAMPLE:** CM6YL
6. TO SPECIFY HEAT TREATED STUD, ADD SUFFIX "YX" TO PART NUMBER. **EXAMPLE:** CM6YX
7. FOR LOAD RATINGS WITH STUDS, PLEASE CONTACT F.K. ENGINEERING DEPARTMENT.

SPECIAL PRODUCTS



MATERIAL

STEEL - LOW CARBON - ZINC PLATED ALUMINUM

NOTES:

1. JAM NUTS ARE SOLD IN LOTS OF 25 PCS.

INCH STEEL JAM NUTS

RIGHT HAND	LEFT HAND	THREAD SIZE UNF 2B	HEX SIZE
SJNR03	SJNL03	10-32	3/8
SJNR04	SJNL04	1/4-28	7/16
SJNR05	SJNL05	5/16-24	1/2
SJNR06	SJNL06	3/8-24	9/16
SJNR07	SJNL07	7/16-20	11/16
SJNR08	SJNL08	1/2-20	3/4
SJNR10	SJNL10	5/8-18	15/16
SJNR12	SJNL12	3/4-16	1-1/8
* SJNR14	SJNL14	7/8-14	1-9/32
* SJNR16	SJNL16	1-1/4-12	1-13/16
* SJNR16-1	SJNL16-1	1-14	1-3/8
* SJNR16-2	SJNL16-2	1-12	1-3/8

INCH ALUMINUM JAM NUTS

RIGHT HAND	LEFT HAND	THREAD SIZE UNF 2B	HEX SIZE
AJNR03	AJNL03	10-32	3/8
AJNR04	AJNL04	1/4-28	7/16
AJNR05	AJNL05	5/16-24	1/2
AJNR06	AJNL06	3/8-24	9/16
AJNR07	AJNL07	7/16-20	11/16
AJNR08	AJNL08	1/2-20	3/4
AJNR10	AJNL10	5/8-18	3/4
AJNR12	AJNL12	3/4-16	1-1/8

* HEX SIZE MAY VARY DEPENDING ON AVAILABILITY OF MATERIAL.

METRIC STEEL JAM NUTS

RIGHT HAND	LEFT HAND	THREAD SIZE 6H	HEX SIZE
SJNR5M	SJNL5M	M5 X 0.8	3/8
SJNR6M	SJNL6M	M6 X 1.0	7/16
SJNR8M	SJNL8M	M8 X 1.25	1/2
SJNR10M	SJNL10M	M10 X 1.5	9/16
SJNR12M	SJNL12M	M12 X 1.75	11/16
SJNR14M	SJNL14M	M14 X 2.0	3/4
SJNR16M	SJNL16M	M16 X 2.0	15/16
SJNR18M	SJNL18M	M18 X 1.5	1 3/32
SJNR20M	SJNL20M	M20 X 1.5	1 3/32



SPECIAL PRODUCTS

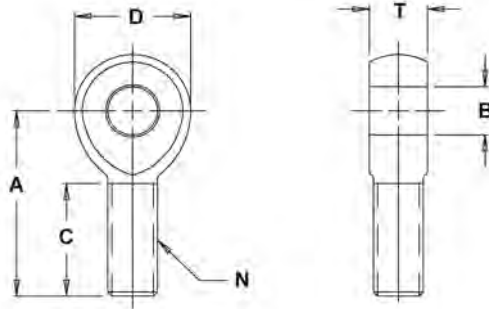

SOLID ROD ENDS

MATERIALS

LOW-CARBON STEEL
ZINC PLATED

PART NUMBER	BORE X THD.	B DIA.	D DIA.	T WIDTH	A LENGTH	C LENGTH	N THREAD	ULT. RADIAL STATIC LOAD (lbs.)
	REF.	+0.0025 -0.0005	+0.010 -0.010	+0.005 -0.005	+0.015 -0.015	+0.062 -0.031	UNF 3A	
RD1	5/8 x 5/8	.6250	1.500	.750	2.625	1.625	5/8-18	16,600
RD2	5/8 x 3/4	.6250	1.750	.875	2.875	1.750	3/4-16	18,500
RD3	3/4 x 3/4	.7500	1.750	.875	2.875	1.750	3/4-16	18,500
RD4	1/2 x 1/2	.5000	1.312	.625	2.437	1.500	1/2-20	12,100
RD5	1/2 x 3/4	.5000	1.750	.875	2.875	1.750	3/4-16	18,500
RD8	1/2 x 3/4	.5000	1.500	.750	2.625	1.625	3/4-16	18,500

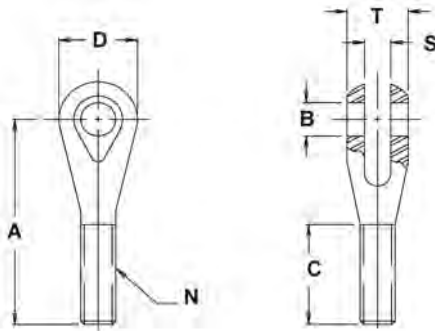

CLEVIS

MATERIALS

LOW-CARBON STEEL
ZINC PLATED
CHROMATE TREATED

NOTES:

- 17-4 PH STAINLESS STEEL OFFERED ON SIZES: 1 & 2
EXAMPLE: SCV1 & SCV2

PART NUMBER	BORE X THD.	B DIA.	D DIA.	T WIDTH	A LENGTH	C LENGTH	S SLOT	N THREAD
	REF.	+0.0025 -0.0005	+0.010 -0.010	+0.005 -0.005	+0.015 -0.015	+0.062 -0.031	+0.005 -0.005	UNF 3A
CV1	3/8 x 5/8	.3750	1.125	.825	3.375	2.000	.375	5/8-18
CV2	1/2 x 5/8	.5000	1.125	.825	3.375	2.000	.375	5/8-18
CV3	3/8 x 3/4	.3750	1.125	.825	3.375	2.000	.375	3/4-16
CV4	1/2 x 3/4	.5000	1.125	.825	3.375	2.000	.375	3/4-16
CV5	3/8 x 1/2	.3750	.875	.655	3.012	1.700	.250	1/2-20
CV8	9/16 x 1/2	.5625	1.125	.875	5.563	3.900	.250	1/2-20

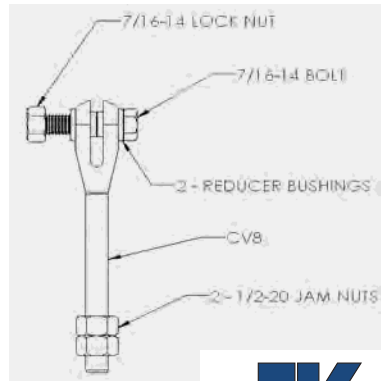

PART NO.

CV8-ASM



WELDABLE TUBE ENDS

TUBE SIZE X WALL THICKNESS	10-32	1/4-28	5/16-24	3/8-24	7/16-20	1/2-20	5/8-18	3/4-16	7/8-14	1-14	1 1/4-12
3/8 X .058	1101										
1/2 X .058		1202	1203								
5/8 X .058			1303	1304	1305						
3/4 X .058			1403	1404	1405						
3/4 X .065			1503	1504	1505						
7/8 X .058				1604	1605	1606					
7/8 X .065				1704	1705	1706					
7/8 X .083				1804	1805	1806					
1" X .058				1904	1905	1906	1907				
1" X .065				2004	2005	2006	2007				
1" X .083				2104	2105	2106	2107				
1" X .095				2204	2205	2206	2207				
1 1/8 X .058						2306	2307				
1 1/8 X .065						2406	2407				
1 1/8 X .083						2506	2507	2508			
1 1/8 X .095						2606	2607	2608			
1 1/4 X .095							2707	2708			
1 1/4 X .120							2807	2808			
1 3/8 X .095							2907	2908			
1 3/8 X .120							3007	3008			
1 1/2 X .095							3057	3058			
1 1/2 X .120							3108	3109			
1 1/2 X .250							3208	3209			
1 3/4 X .120							3308	3309	3310	3311	
1 3/4 X .250							3408	3409	3410		

NOTE:

All tube ends are made from 4130 chromemoly. Left-handed threaded parts have a distinctive mark around the outside diameter. F.K. Bearings makes no warranties, expressed or implied, as the suitability of our Tube Ends for any application. Tube Ends must be welded in place by a skilled welder, using good welding techniques.



RERS SERIES SEALS

TOTALLY ENCLOSE AND PROTECT THE ROD END FROM DIRT AND WATER



BOOT SIZE PART NUMBER	INCH SIZE ROD ENDS		METRIC SIZE ROD ENDS	
	MALE	FEMALE	MALE	FEMALE
RERS 1	3/16", 1/4", 5/16"	3/16", 1/4", 5/16"	6mm, 8mm	6mm, 8mm
RERS 2	3/8", 7/16"	3/8", 7/16"	10mm, 12mm	10mm, 12mm
RERS 3	1/2", 5/8", 3/4"	1/2", 5/8", 3/4"	14mm, 16mm, 18mm	14mm, 16mm, 18mm
RERS 4	7/8", 1"	7/8", 1"	20mm, 22mm, 25mm	20mm, 22mm, 25mm
RERS 5	1 1/4"	1 1/4"	30mm, 35mm	30mm, 35mm

NOTE: STANDARD PACKAGING IS SIX (6) SEALS PER PACKAGE.



WS SERIES SEALS

ECONOMICAL PROTECTION FOR YOUR ROD END

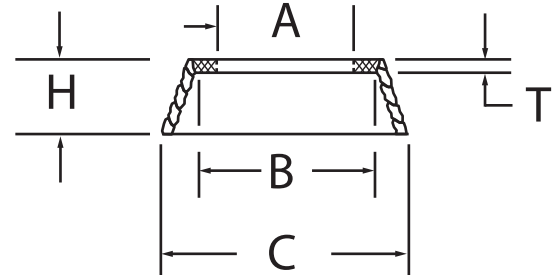

STANDARD SIZES

PART NUMBER	ROD END SIZE	SIZE	A	B	C	H	T
WS 1875	3	0.187	0.200	0.326	0.442	0.095	0.020
WS 2500	4	0.250	0.260	0.375	0.500	0.120	0.027
WS 3125	5	0.312	0.322	0.487	0.700	0.200	0.047
WS 3750	6	0.375	0.385	0.530	0.800	0.220	0.047
WS 4375	7	0.437	0.448	0.626	0.875	0.250	0.047
WS 5001	8	0.500	0.510	0.730	1.125	0.250	0.047
WS 6250	10	0.625	0.635	0.882	1.235	0.267	0.047
WS 7500	12	0.750	0.760	1.006	1.381	0.367	0.047
WS 8750	14	0.875	0.885	1.125	1.890	0.315	0.042
WS 1000	16	1.000	1.010	1.230	2.100	0.500	0.050

METRIC

PART NUMBER	ROD END SIZE	A	B	C	H	T
WS 5MM	5	5.25	8.28	11.22	2.41	0.50
WS 6MM	6	6.25	9.53	12.70	3.05	1.69
WS 8MM	8	8.25	12.37	17.78	5.08	1.20
WS 10MM	10	10.25	13.46	20.32	5.59	1.20
WS 12MM	12	12.25	18.54	28.58	6.35	1.20
WS 14MM	14	14.25	18.54	28.57	6.35	1.20
WS 16MM	16	16.25	22.40	31.70	6.80	1.20
WS 18MM	18	18.25	22.60	32.69	8.25	1.20
WS 20MM	20	20.25	25.15	38.10	10.16	1.20
WS 25MM	25	25.25	33.80	53.30	12.70	1.50
WS 30MM	30	30.25	36.00	55.88	13.45	1.50

Note: * One (1) rod end requires two (2) rod end seals.
 * Standard packaging is six (6) seals per package.
 * One pack seals three (3) rod ends.



ENGINEERING DATA



RADIAL LOAD - A LOAD APPLIED NORMAL TO THE BEARING BORE AXIS AND PARALLEL TO THE SHANK AXIS.



AXIAL LOAD - A LOAD APPLIED ALONG THE BEARING BORE AXIS.

STATIC RADIAL LIMIT LOAD - THAT STATIC LOAD REQUIRED TO PRODUCE A SPECIFIED PERMANENT SET IN THE BEARING STRUCTURE. IT WILL VARY FOR A GIVEN SIZE AS A FUNCTION OF CONFIGURATION. IT MAY ALSO BE PIN LIMITED AS A FUNCTION OF BODY RESTRAINTS AS IN THE CASE OF ROD END BEARINGS.

STATIC RADIAL ULTIMATE LOAD - THAT LOAD THAT CAN BE APPLIED TO A BEARING WITHOUT FRACTURING THE BALL, RACE, OR ROD END EYE. THE ULTIMATE LOAD RATING IS USUALLY, BUT NOT ALWAYS, 1.5 TIMES THE LIMIT LOAD.

STATIC AXIAL LIMIT LOAD - THAT LOAD THAT CAN BE APPLIED TO A BEARING TO PRODUCE A SPECIFIED PERMANENT SET IN THE BEARING STRUCTURE.

STATIC AXIAL ULTIMATE LOAD - THAT LOAD THAT CAN BE APPLIED TO A BEARING WITHOUT SEPARATING THE BALL FROM THE RACE. THE ULTIMATE LOAD RATING IS USUALLY, BUT NOT ALWAYS, 1.5 TIMES THE LIMIT LOAD.

ANGLE OF MISALIGNMENT

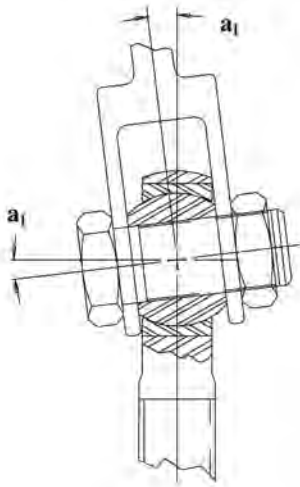

FIGURE 1

$$a_1 = \sin^{-1} \frac{W}{D} - \sin^{-1} \frac{H}{D}$$

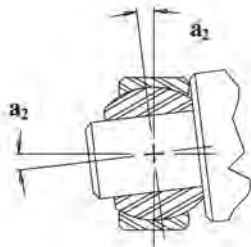

FIGURE 2

$$a_2 = \sin^{-1} \frac{W}{A} - \sin^{-1} \frac{H}{A}$$

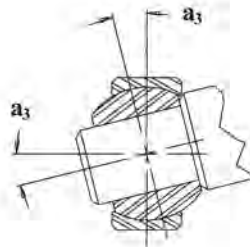

FIGURE 3

$$a_3 = \sin^{-1} \frac{W}{R} - \sin^{-1} \frac{H}{R}$$

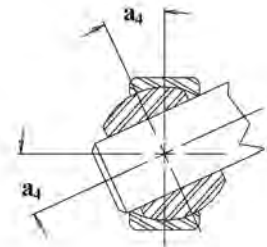

FIGURE 4

$$a_4 = \cos^{-1} \frac{B}{R} - \sin^{-1} \frac{H}{R}$$

- B** - Ball Bore
- M** - Outer Race Chamfer
- D** - Head Diameter or Outer Race Diameter
- R** - Ball Diameter
- H** - Housing Width
- A** - $\sqrt{(D-2M)^2 + H^2}$
- W** - Ball Width



INTERCHANGE TABLE

F.K.	ALINABAL	AURORA	HEIM / BOSTON	MORSE / SPHERCO	TUTHILL	NMB / NHBB
MALE ROD ENDS						
CM	AM-GP	CM	M-CR	CFM	MSM	AHM / LSPL
CM-T	AM-T-GP	VCM		CFM-T	MSM-T	
CM-Y	AM-S-GP	CM-S	M-CRY	CFM-Y	MSM-S	
CM-Z	AM-8	CM-Z	M-CRG	CFM-N	MSM-Z	
CM-M		CM-M			EM-M	
CMX		RM-X5			MAX	
M		BM	HM	TRE		
M-SB	VM-G		HM-C	TM	MBM	
NJM	PM		CMHD	CTMD	NM/SPM	
JM	LCTM-X5	MM / KM	HMA		MTSM	HAMR
JM-T		MM-T / KM-T	HME	TRE-T	MTSM-T	AMRT
JMX	RM-X5	AM	BHM	ARE	TSMX	HAMRX
RJMX-T		RAM-T			NSMX-T	
RSM	LCRM-1-X5	XM			RM	AXM
RSMX	RM-1-X5	XAM			RMX	XAMX
RRSMX-T		RXAM-T				
HRSMX-T		HXAM-T				ARYT-ECR
PMX-T		PRM-T				ART-ES
KMX						
ALJM/ALJMH	ARM-X5	ALM			KCA	ALRE
ALRSM	ARM-1-X5	XALM			KCAX	XALRE
SCM-T		CM-ET			SSM-T	
SJM-T		SM-ET	ME		SSAM-T	ART-ECR
SRSM-T					SSHM-T	ARHT-ECR
SCM-MT						
FEMALE ROD ENDS						
CF	AF-GP	CW	F-CR	CFF	MSF	AHF-CSPL
CF-T	AF-T-GP	CW-T		CFF-T	MSF-T	
F		BW	HF	TR		
F-SB	VF-G		HFC	TF	MBF	
NJF	PF		CFHD	CTFD	NF/SPF	
JF	CF	MW / KW	HFA		MTSF	HAFR
JF-T		MW-T / KW-T	HFE	TR-T	MTSFT	AFRT
JFX		AW		AR	TSFY	HAFRX
ALJF						
SCF-T		CW-ET			SSF-T	
SJF-T		SW-ET			SSAF-T	ART-CR
SCF-MT						
SPHERICAL BEARINGS						
COM	COM-E	COM	COM	COM	COM	CBG
COMH		HCOM		BH-LS		RSH
HIN-T		HAB-T			YSSB	ABYT
K	VBC-G		LS	FLBG		ASL-G
FKS		COM-KH	LHA	SBGS		RS
FKS-T		COM-KHT				RS-T
FKSSX-T		NC-T	NE/LHSSE	NRR	NSSB	ABT
FKSSX-TV		NC-TG	NE-G/LHSSV V	NRRG	NSSB-V	ABT-V
WSSX-T		WC-T	WE	WRR	WSSB	ABWT
WSSX-TV		WC-TG	WE-G	WRRG	WSSB-V	ABWT-V

NOTE: This interchange table shows approximate equivalency. It is not intended that all manufacturers' products are functionally interchangeable in all applications. F.K. Bearings reserves the right to change specifications and other information included in this catalog without notice. All information, data, and dimension tables in this catalog have been carefully compiled and thoroughly checked. However, no responsibility for possible errors or omissions can be assumed.



WARNING!

The manufacturer can not determine all applications of its products. It is up to the customer to determine a suitable part for their application. For assistance, please contact F.K.'s Engineering Department.

Catalog 082



F.K. Bearings

865 W. Queen St.
Southington, CT 06489

800-662-4003

860-628-8722

860-276-0463-Fax

www.fkrodends.com

Distributed By: