

Instruction Manual for DODGE SLEEVOIL RXT® Pillow Blocks With Self Lubrication (oil ring)

These instructions must be read thoroughly before installation or operation.

CAUTION: Do not scrape, rebabbitt, or otherwise alter this product. Such action adversely affects bearing performance and may result in damage or destruction of equipment.

WARNING: Only qualified personnel familiar with the construction and operation of this equipment and the hazards involved should install, adjust, operate and/or service it. Read and understand this manual in its entirety before proceeding. Failure to observe this precaution could result in severe bodily injury or loss of life.

INSTALLATION:

The modular design of this bearing allows the use of multiple types of liners and two or more bore sizes in the same housing.

Types of Liners

'S' — Standard liner (fixed or free) has symmetrical thrust faces for bidirectional rotation.

'T' — High thrust, non-expansion (fixed) liner has tapered land thrust faces which **MUST** be oriented with shaft rotation as this type of thrust surface is unidirectional; Used with external circulating oil lubrication only.

1. PRE-ASSEMBLY INSTRUCTIONS

Sleeve bearing performance is dependent on proper installation, lubrication and maintenance. Before assembling the bearing, read ALL instructions in this manual and follow all equipment manufacturers' instructions.

DODGE SLEEVOIL PILLOW BLOCK NAMEPLATE

All SLEEVOIL housings and liners have nameplates attached to them. These nameplates have a six digit part number which fully identifies the housing and/or liner with any and all factory modifications to that part. Liner nameplate is pinned to the SLEEVOIL upper liner near an oil ring inspection hole. Housing nameplate is pinned to the housing foot parallel to the shaft.

WARNING: Because of the possible danger to person(s) or property from accidents which may result from the improper use of products, it is important that correct procedures be followed: Products must be used in accordance with the engineering information specified in the catalog. Proper installation, maintenance and operation procedures must be observed. The instructions in the instruction manuals must be followed. Inspections should be made as necessary to assure safe operation under prevailing conditions. Proper guards and other suitable safety devices or procedures as may be desirable or as may be specified in safety codes should be provided, and are neither provided by Dodge nor are the responsibility of Dodge. This unit and its associated equipment must be installed, adjusted and maintained by qualified personnel who are familiar with the construction and operation of all equipment in the system and the potential hazards involved. When risk to persons or property may be involved, a failsafe device must be an integral part of the driven equipment beyond the speed reducer output shaft.

DODGE SLEEVOIL PILLOW BLOCK "MATCH MARKS"

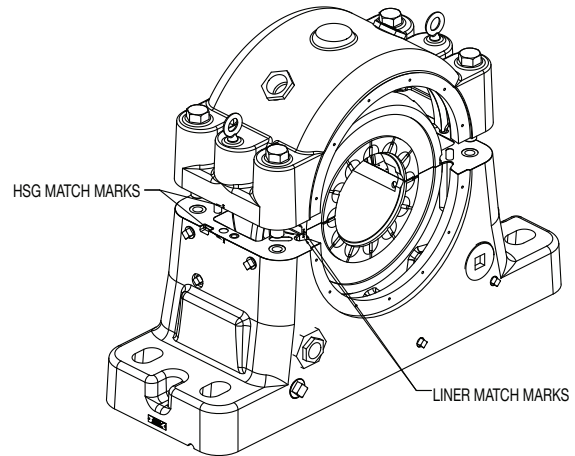

All SLEEVOIL housing and liner halves have match marks permanently stamped above and below the joint. Use these match marks to ensure that parts stay paired and critical machined areas of an assembly are accurately maintained.

NOTE: Refer to applicable contract/assembly drawings to verify all parts are available prior to assembly.

Disassemble and thoroughly clean all parts of the pillow block. The installer is the last person to inspect all parts for fit, damage and cleanliness. Care **MUST** be taken to avoid contaminating the internal surfaces of the bearing. Housing caps and bases are match marked and **MUST NOT** be interchanged. Upper and lower liners are also match marked and **MUST NOT** be interchanged.

NOTE: DO NOT DISCARD SHIMS AT JOINT. THEY ARE USED LATER FOR A CONTROLLED INTERFERENCE FIT OF LINER IN HOUSING. (See page 4)

CAUTION: Liner assembly has critical machined surfaces which are easily damaged. Use care when handling to protect these surfaces. Liner parts should be placed on a soft, **CLEAN** surface. Failure to observe these precautions may result in damage to or destruction of the equipment.

WARNING: Rust preventives and solvents can be toxic and/or flammable. Follow directions and safety procedures recommended by their manufacturers. Failure to observe these precautions could result in bodily injury.

Check the mounting structure to ensure it is rigid, leveled, and well supported. Inspect the shaft to ensure it is smooth (32 rms or 0.8 microns finish or better), free of burrs or rough spots and clean. Position the housing base on the pedestal in the position specified on the construction drawing. Do **NOT** tighten the base to the pedestal.



2. INSTALLATION OF LOWER LINER AND SHAFT

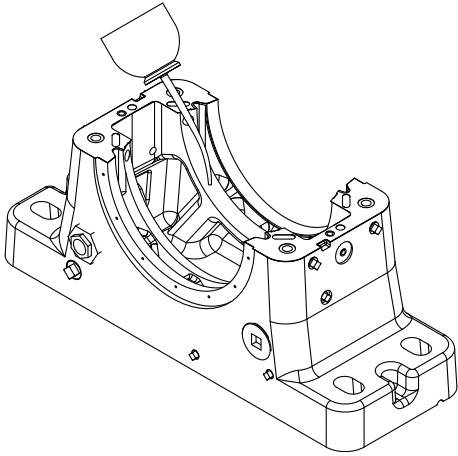

Apply oil to the spherical seats of the housing base and to the spherical seats of the lower liner half. The lower liner half is identified by its continuous babbitted bore surface; the upper liner half has one or two oil ring slot(s) in the center of the babbitted bore.

Set lower liner in housing base so spherical seats of liner are aligned with spherical seats of base. Horizontal split of liner MUST align with horizontal split of housing for anti-rotation pins in upper liner to engage holes in housing cap. Take care that circulating oil inlets and thermocouple holes in liner and housing base are aligned.

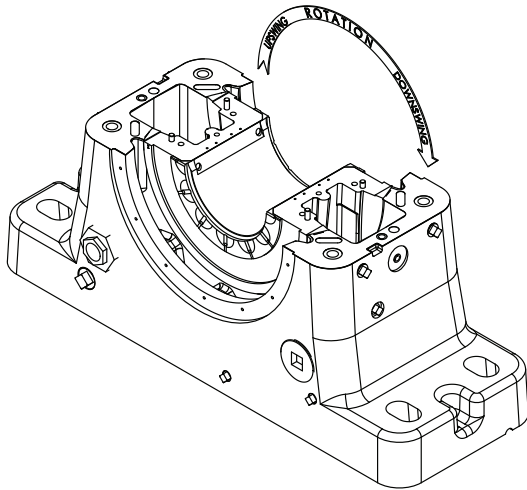

Apply oil to the lower liner bore or to the shaft in liner area and CAREFULLY set the shaft in place, taking care not to damage the babbitted surface.

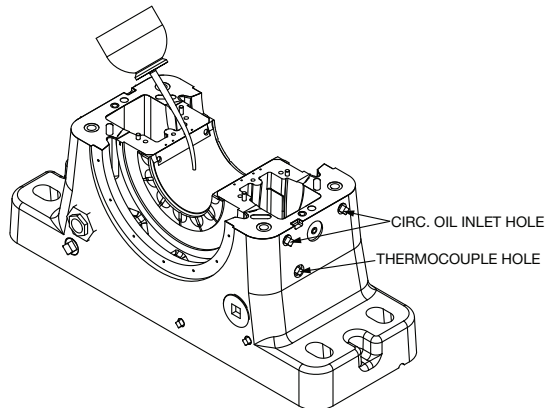

2.1 LABYRINTH SEAL

Attach lower half of each oil seal to housing base. Check possible alignment of oil seal by visually noting an equal clearance between seal and shaft at each end of the housing. The seals can be adjusted somewhat but MUST NOT contact the shaft at any point.

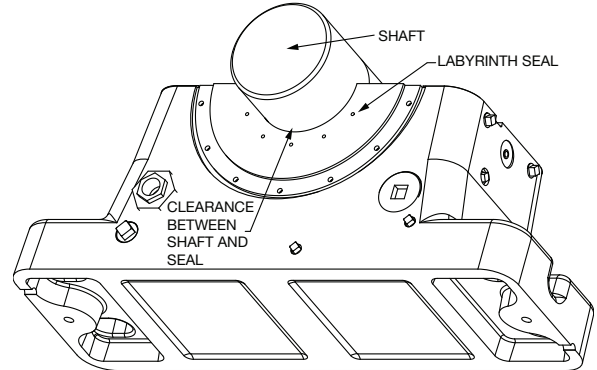

Re-shim pillow block, if necessary. Always shim under the bearing pedestal where possible; otherwise, use full length shims under base of pillow block.

NOTE: Remove lower half of each labyrinth seal from housing after this preliminary alignment to avoid damaging the lip of the labyrinth.

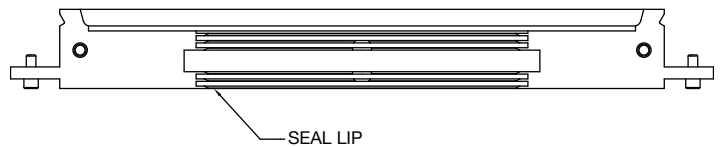

2.2 OIL DAM and COL (See page 11)

Oil Dam - Small rectangular piece of preformed sheet metal used to block off most of oil ring slot in upper liner; attaches to lower liner.

COL (Collector Oil Leaf) - Oil dam with an extended "finger" to stabilize oil rings; used for bores 6" and larger.

2.2.1 FOR BORES 2-15/16" through 5-7/16"

'S' liner: One oil dam on each side of the shaft (because shaft rotation can be either direction).

2.2.2 FOR BORES 6" through 12"

'S' liner: One oil dam and one COL on each side of shaft. COLS must be diagonally across from one another.

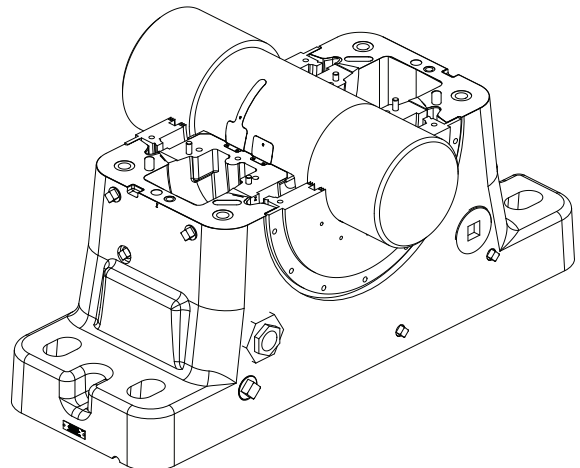

Shaft Diameter	2-15/16	3-17/16	3-15/16	4-7/16	4-15/16	5-7/16
Tip of oil dam to shaft	5/32	5/32	1/8	1/8	1/8	1/8
Shaft Diameter	6	7	8	9	10	12
Tip of oil dam to shaft	11/32	11/32	9/32	9/32	1/2	1/2
Tip of COL to shaft	1/4	5/16	5/16	5/16	5/16	13/32

3. INSTALLATION OF OIL RING (S)

Each ring is match marked and **MUST NOT** be interchanged. Place oil ring(s) around lower liner and shaft. Install and tighten four screws in each oil ring.

Oil dams can be adjusted, if necessary, to avoid contact with oil ring. Loosen screws and move dam; bend base of dam, if necessary, to obtain clearance in Table 1.

Oil shaft under oil ring(s). Make sure oil ring(s) rotate freely.

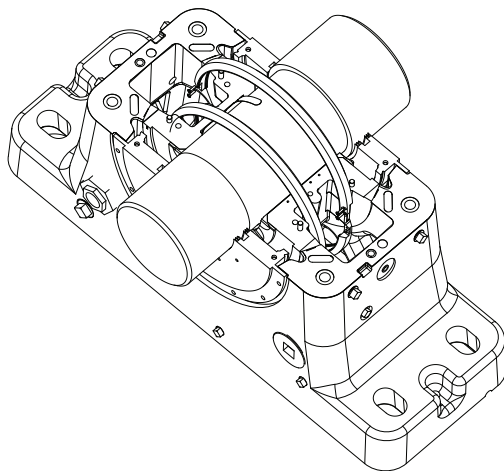

FOR BORES 6" THROUGH 12": Narrow leaf of COL will contact oil ring inside wide groove as shown below. COL can be adjusted to align leaf with wide oil ring groove. Loosen screws and move COL; do NOT bend or distort COL. Tighten screws.

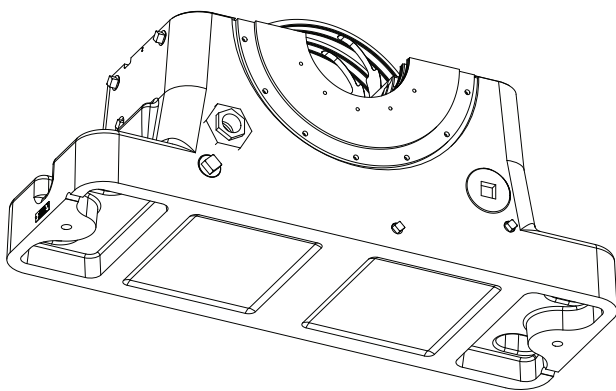

4. NON-EXPANSION BEARINGS WITH DODGE SPLIT THRUST COLLARS ('S' LINERS ONLY)

Split thrust collars are available for 'S' liners only. Remove clamp screws from collars. Remove jam screws and back out set screws so they do not protrude into inside diameter of collar.

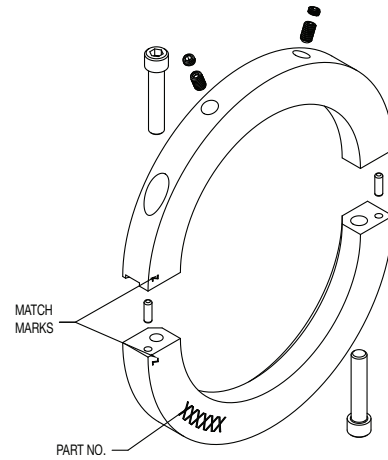

Place one half of collar on shaft with large chamfer next to shaft shoulder. Rotate collar half around shaft and place other half in position.

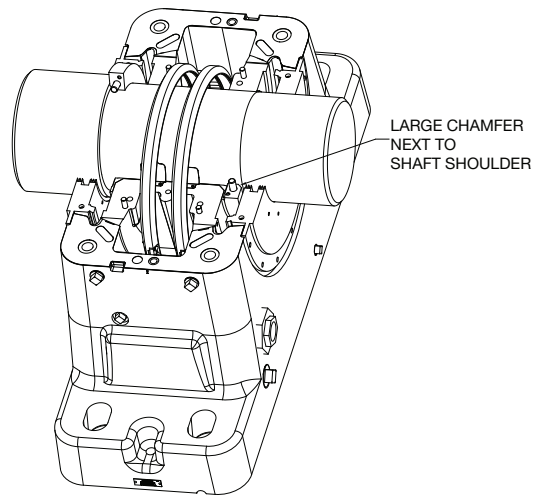

NOTE: Collar halves are match marked; do NOT assemble halves with different marks.

Tighten clamp screws to torque specified in Table 2. Collar faces **MUST NOT** be offset at split. Repeat for second collar.

Locate collars tight against shaft shoulders. This will allow **0.015 to 0.035 inch** total running clearance between collars and liner thrust faces. Tighten set screws to torque specified in Table 2. Install and tighten jam screws on top of set screws.

Shaft Size (inches)	2-15/16	3-7/16	3-15/16	4-7/16	4-15/16	5-7/16
Clamp Screw	(96) 8	(96) 8	(96) 8	(96) 8	(204) 17	(204) 17
Set Screw	(60) 5	(60) 5	(60) 5	(60) 5	(132) 11	(132) 11

Shaft Size (inches)	6	7	8	9	10	12
Clamp Screw	(360) 30	(360) 30	(900) 75	(900) 75	(1800) 150	(1800) 150
Set Screw	(264) 22	(264) 22	(264) 22	(264) 22	(1320) 110	(1320) 110

5. INSTALLATION OF UPPER LINER

Apply oil to faces of thrust collars next to liner and to shaft in journal area and to journal surface of upper liner.

Locate upper liner in place on lower liner, taking care to align dowel pins and match marks. (The upper liner has a recess(es) for the oil ring(s)). Make sure oil ring(s) rotate freely.

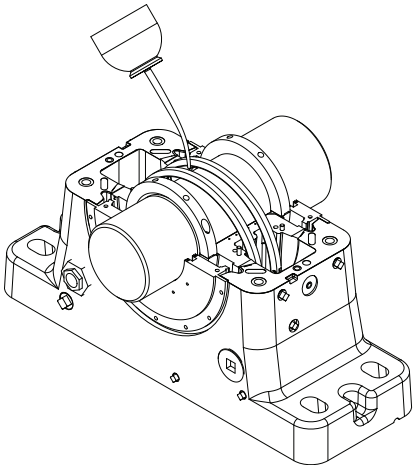

Install and tighten liner cap screws to torque listed in Table 3.

Shaft Size (inches)	2-15/16	3-7/16	3-15/16	4-7/16	4-15/16	5-7/16
Liner Cap Screw	(58) 5	(58) 5	(58) 5	(58) 5	(114) 10	(114) 10

Shaft Size (inches)	6	7	8	9	10	12	14
Liner Cap Screw	(114) 10	(114) 10	(510) 43	(510) 43	(1050) 88	(1050) 88	(1050) 88

Collars should run parallel to thrust faces of liner within **.001 in.** Tighten housing base to pedestal. See Table 4 for torque.

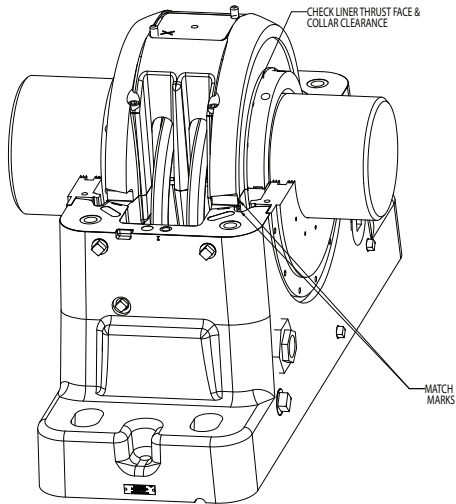

Recheck clearance (**0.015 to 0.035 in. total**) and parallelism (**0.002 in max.**) of thrust collars to liner faces.

Housing Size	3	4	5	6	8	10
Housing to Pedestal Bolts	(2000) 167	(3600) 300	(4600) 383	(8400) 700	(11500) 958	(15000) 1250
Housing to Cap Bolts	(1560) 130	(2280) 190	(2280) 190	(2280) 190	(3240) 270	(3240) 270

6. INSTALLATION OF HOUSING CAP

Position shims on each side of housing. Put a short strip of Plastigage (3 inches) on liner spherical ribs at top of each rib of liner and near the middle of spherical ribs.

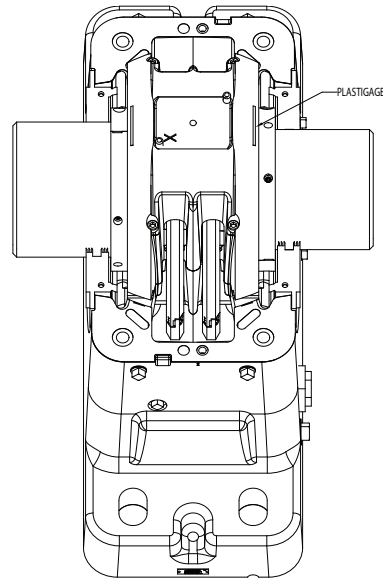

NOTE: New housing shims are required with replacement liners.

CAREFULLY set housing cap in place.

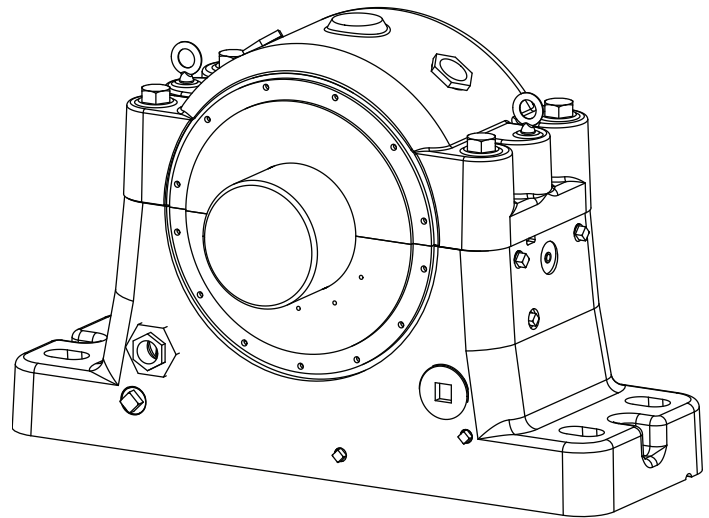

NOTE: Align dowel pin and dowel pin hole in housing halves before lowering cap onto base.

Tighten housing cap bolts to torque specified in Table 4. Remove cap bolts and housing cap.

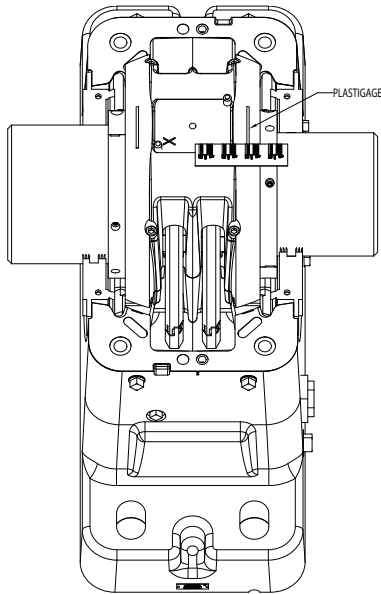

Compare the width of the deformed Plastigage with the inch scale on its wrapper. This indicates the clearance between housing and liner.

Shims provided are multiple layers of .002 inch thickness each. Separate and remove layers, per Table 5. Do this for both shims. This will provide a controlled interference fit between housing and liner (.003 to .004 in. interference desired).

Clearance Measured (Inches)	Shims to Remove
0.001	2
0.002	3
0.003	3
0.004	4
0.005	4

Align shims as required. CAREFULLY replace housing cap. Torque cap bolts to values specified in Table 4.

7. SEAL INSTALLATION

Apply sealant to seal mounting surfaces of housing.

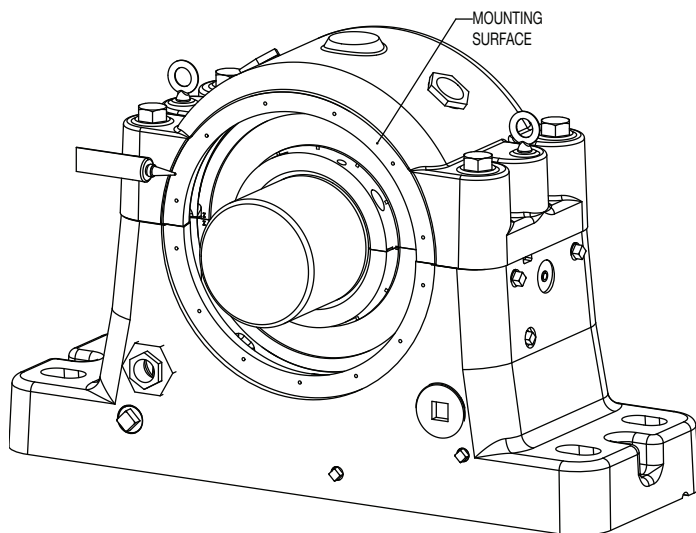

Assemble each seal around shaft and torque clamp screws to value specified in Table 6. Align seals per values given in Table 6.

NOTE: Check the construction drawing for seal size and position as three different seal bore sizes can be used on any housing. Seals can be reversed depending on shaft configuration and spacing.

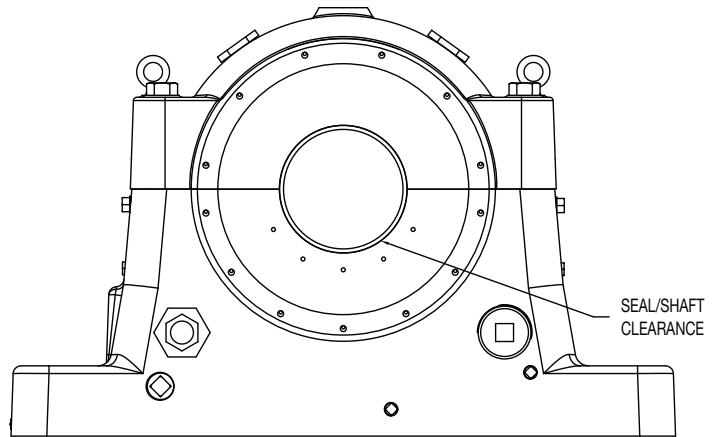

Shaft Diameter	2-15/16	3-7/16	3-15/16	4-7/16	4-15/16	5-7/16
Bottom of Shaft to Seal	0.001	0.001	0.001	0.001	0.001	0.001
Side of Shaft to Seal	0.003 - 0.006	0.003 - 0.006	0.004 - 0.007	0.004 - 0.007	0.005 - 0.008	0.005 - 0.008

Shaft Diameter	6	7	8	9	10	12	14-1/2
Bottom of Shaft to Seal	0.002	0.002	0.002	0.002	0.003	0.003	0.003
Side of Shaft to Seal	0.006 - 0.009	0.007 - 0.010	0.008 - 0.011	0.009 - 0.012	0.010 - 0.013	0.012 - 0.015	0.014 - 0.018

Housing Size	3	4	5	6	8	10
Clamp Screws	12	12	12	25	45	45
Mounting Screws	40	40	40	40	40	40

Torque seal mounting screws to value given in Table 7.

Assemble well-nut, washer and screw

Install well-nut in drain hole on outer face of seal. Tighten screw until well-nut is tight in hole.

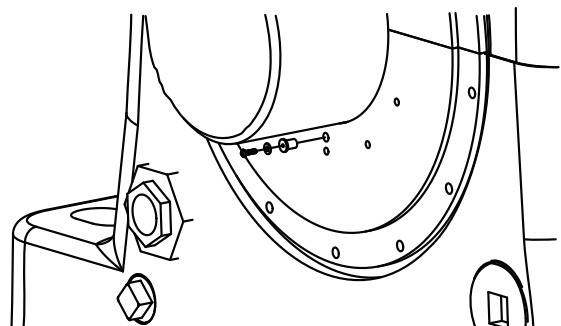

8. MISCELLANEOUS INSTRUCTIONS

Remove all unused pipe plugs, apply sealant and replace. Tighten securely. Install oil sight gauge in specified location.

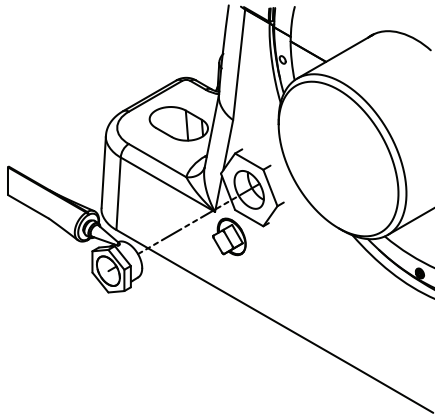

Note: Each housing base has two pre-drilled holes for doweling housing to pedestal.

9. LUBRICATION AND OPERATION

Fill pillow block with the amount of oil specified in Table 8.

Table 8 - Housing Oil Sump Capacity	
Housing Size	Oil Capacity in Gallons (Quarts)
3	1-1/4 (5)
4	1-7/8 (7-1/2)
5	2-1/2 (10)
6	3-1/4 (13)
8	5-1/8 (20-1/2)
10	7-3/4 (31)

Drain, flush and refill with oil after 2 or 3 weeks of operation and approximately every 3 months thereafter for 24 hours-a-day service and every 6 months for 8-hours-a-day service. Periodically check oil visually for contamination between oil changes.

CAUTION: If heaters are used, they must be turned OFF when oil is removed from the bearing. Failure to observe this precaution could result in equipment damage.

NOTE: Maintain oil level at center of oil sight gauge when bearing is operating. After placing bearing into operation, remove the inspection cover(s) and make sure the oil rings are rotating and bringing oil into the journal. Since the satisfactory operation of the pillow block depends almost entirely on the oil film being maintained between the shaft and bearing liner surface, the use of high quality oil from a reputable manufacturer cannot be overemphasized. Use a high grade straight mineral oil with rust and oxidation (R & O) inhibitors and antifoam agents. Oil viscosity is determined by the equipment manufacturer and normally specified on the construction drawing or in the operating manual, otherwise, see Table 8. Information regarding qualities and properties of specific oils should be referred to the lubricant manufacturer.

Oil film temperature in liner during operation should not exceed 180°F. If in doubt, consult equipment manufacturer.

Use high grade, high quality, well refined petroleum oils of the straight mineral type, with rust and oxidation inhibitor and antifoam agent only.

NOTE: Bearings should NOT be stored outdoors before installation. For extended or outdoor storage, contact equipment manufacturer for special precautions against corrosion.

NOTE: Bearings (and shafts) allowed to set idle for extended periods after being run MUST be protected against corrosion. If the unit cannot be run for several minutes at least once a week, consult equipment manufacturer for special lubrication instructions.

9.1 Temperature

The bearing temperature will increase after start-up until its normal operating level is reached. Some fluctuation due to ambient temperature change is normal, but a drastic change MUST be investigated. Normal running temperature should not exceed 180°F. (Check with equipment manufacturer to see if another operating temperature has been specified.) Low ambient and operating temperatures can be as harmful to the bearing as high temperatures. A heater and thermoswitch is required for such applications.

9.2 Minimum Temperature at Start-Up:

ISO 32 oil, 60°F
 ISO 68 oil, 85°F
 ISO 100 oil, 100°F

9.3 Vibration:

Any significant vibration or imbalance MUST be corrected. Check with equipment manufacturer for acceptable conditions.

9.4 Options Available:

- **Heater and Thermoswitch:**

WARNING: When installing heater and thermoswitch, follow directions and safety procedures recommended by the manufacturer. Install wiring in accordance with the National Electrical Code and local codes. Failure to follow these precautions could result in bodily injury.

- **Vibration Detector Kit**

RXT Parts Diagrams

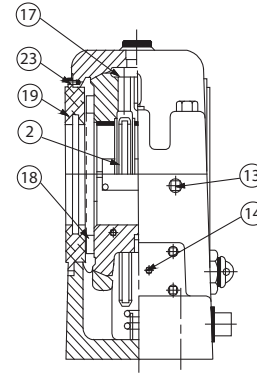
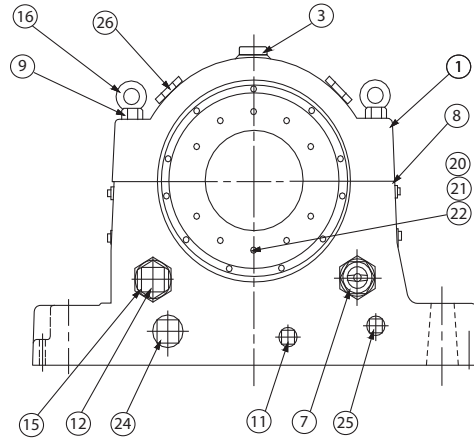

RXT REPLACEMENT PARTS																				
ITEM	DESCRIPTION	NO. REQ'D	Size																	
			3		4		5		6		8		10							
1	Modular Housing Assembly	1	134500		134501		134502		134503		134504		134505							
2	T-section Oil Ring	1,2	130057 (1)		130059 (1)		130062 (1)		130066 (2)		130068 (2)		130073 130071 (2)							
3	• Inspection Cover	1	432197		432197		432197		405043		405043		405043							
7	• Oil Gage	1	432197		432199		432199		432198		432198		432198							
8	• Housing Shim	2	134552		134558		134564		134570		134576		134582							
9	• Housing Bolt	4	411607		411305		411548		411205		411609		411226							
10	• Dowel Pin	2	420088		420088		420088		420144		420144		420144							
11	• Drain Plug	1	430012		430012		430012		430012		430012		430012							
12	• Oil Level Plug	2	430014		430014		430014		430014		430014		430014							
13	• Circulating Oil Plug	4	430017		430019		430019		430022		430022		430022							
14	• Thermocouple Plug	2	430012		430012		430012		430012		430012		430012							
15	• Reducer Bushing	1	-		-		-		430157		430157		430157							
16	• Eye Bolt	2	415138		415138		415138		415138		415138		415142							
	Liner Bore Size		2-15/16" 3-7/16"		3-15/16" 4-7/16"		4-15/16" 5-7/16"		6" 7"		8" 9"		10" 12"							
17	S Liner Assembly	1	134710	134711	134712	134713	134714	134715	134716	134717	134718	134719	134720	134721						
	• Liner Cap Screw	4	417064		417066		417092		417092		417210		417244							
	• Groove Pin	2	409080		409082		409081		409081		409081		409081							
	• Dowel Pin	2,4	420042 (2)		420053 (2)		420053 (2)		420053 (4)		420066 (4)		420088 (4)							
	• Oil Dam	2	134850		134851		134851		134852		134852		134853							
	• COL	2	-		-		-		134840 134841		134842 134843		134844 134845							
	• Screw	4,8	416517 (4)		416517 (4)		416517 (4)		416517 (8)		416517 (8)		416517 (8)							
18	Thrust Collar (S Liner Only)	2	134880	134881	134882	134883	134884	134885	134886	134887	134888	134889	134890	134891						
	• Screw	4	417050	417050	417050	417053	417093	417093	417117	417117	417188	417188	417236	417236						
	• Dowel Pin	4	420040	420040	420040	420040	420043	420043	420043	420043	420043	420043	420080	420080						
	• Set Screw	4	400022	400022	400022	400022	400056	400056	400090	400090	400090	400090	400186	400186						
	• Jam Set Screw	4	415060	415060	415060	415060	400061	400061	400115	400115	400115	400115	400211	400211						
	Seal Bore Size		0215	0307	0407	0315	0407	0600	0415	0507	0800	0600	0700	1000	0800	0900	1200	1000	1200	1450
19	Seal		134860	134861	134863	134864	134866	134867	134869	134870	134872	134873	134875	134876						
			134862		134865		134868		134871		134874		134877							
20	• Shoulder Screw	4	417043		417043		417043		411281		417103		417103							
21	• Well-Nut	2	465435		465435		465435		465435		465435		465435							
22	• Washer	2	419065		419065		419065		419065		419065		419065							
23	• Seal Screw	2	416500		416500		416500		416500		416500		416500							
			411035 (14)		411035 (18)		411035 (18)		411035 (22)		411035 (26)		411035 (30)							
24	Heater Plug	1	430017		430017		430017		430017		430017		430017							
25	Thermostat Plug	1	430012		430012		430012		430012		430012		430012							
26	Inspection Cover	2	-		-		-		432198		432199		432199							

Pillow Block Assembly

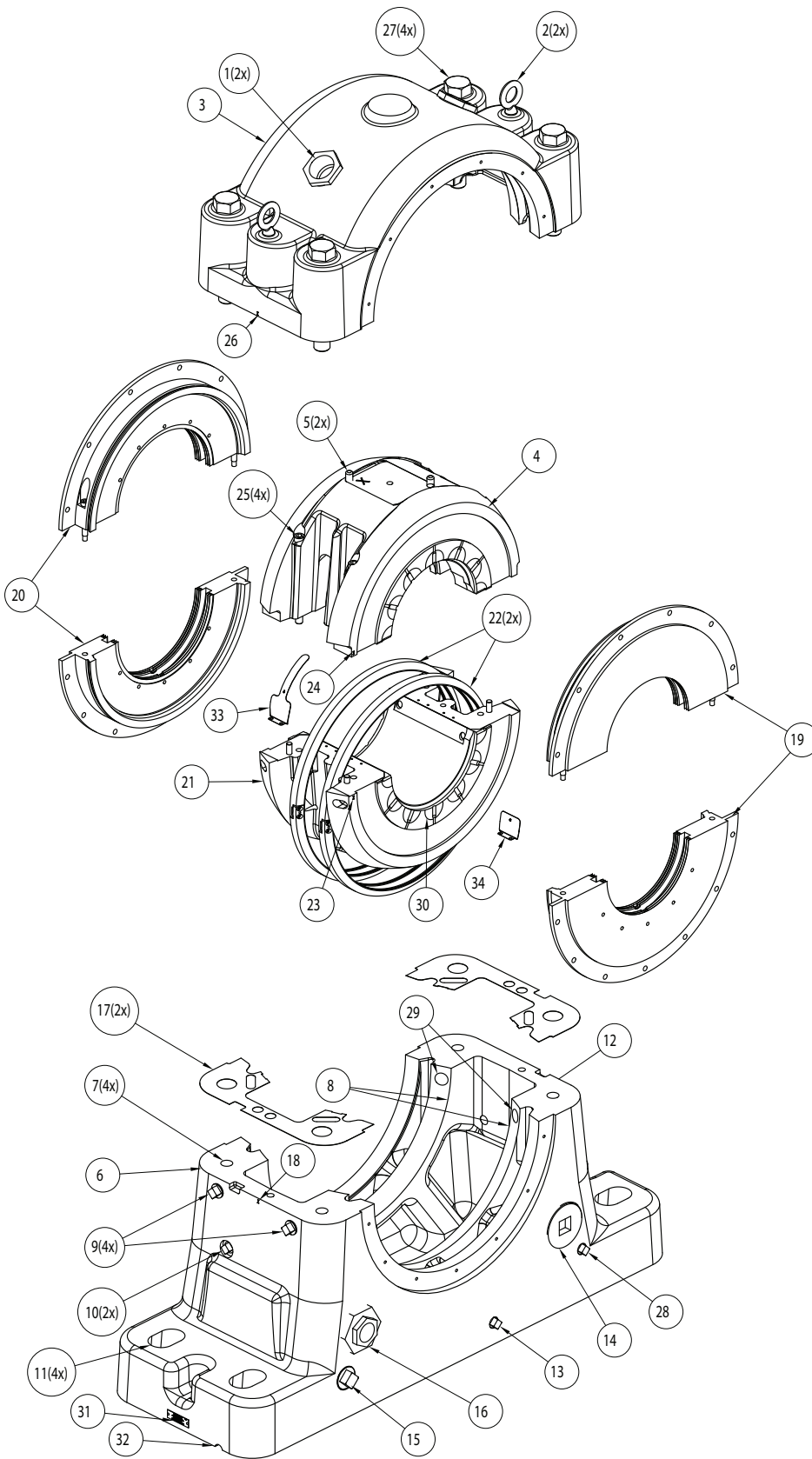

- 1 Inspection cover
- 2 Eye bolt
- 3 Housing cap – top half
- 4 Upper liner – top half
- 5 Anti-rotation pin
- 6 Housing base – lower half
- 7 Housing cap bolts
- 8 Housing spherical seat
- 9 Circulating oil inlet hole (2 each side)
- 10 Thermocouple/RTD hole (one each side)
- 11 Base foot mounting holes
- 12 Vibration detector hole
- 13 Housing drain hole
- 14 Circulating oil drain hole or oil level gauge
- 15 Oil sump heater hole
- 16 Same as 14
- 17 Housing shim
- 18 Housing match mark - base
- 19 Aluminum labyrinth seal
- 20 Aluminum labyrinth seal
- 21 Lower liner – bottom half
- 22 Trapezoidal oil rings
- 23 Liner match mark - lower
- 24 Liner match mark - upper
- 25 Liner cap screws
- 26 Housing match mark - cap
- 27 Housing cap bolts
- 28 Thermostat hole
- 29 Circulating oil holes
- 30 Liner thrust face (S-type)
- 31 Name plate
- 32 Weep hole
- 33 Collector oil leaf
- 34 Oil dam

Oil Ring Assembly

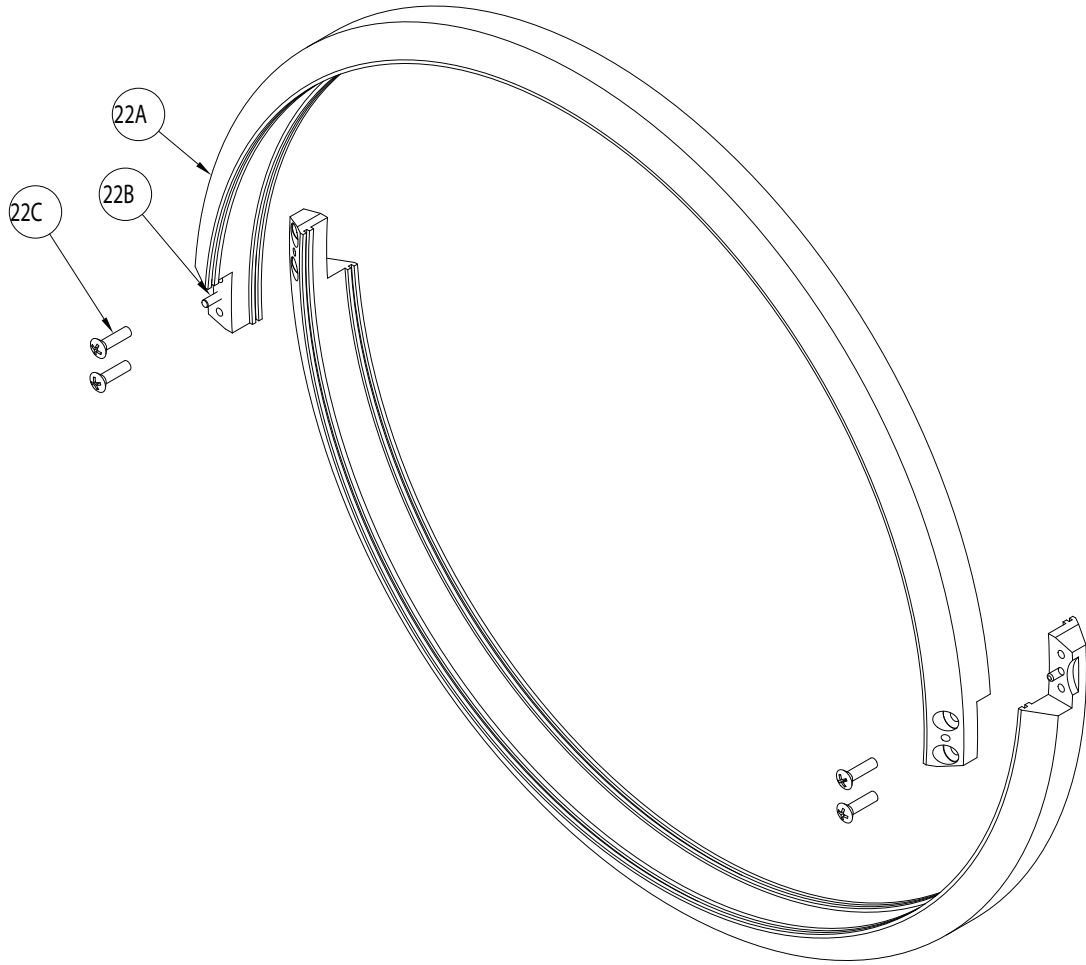

Labyrinth Seal Assembly

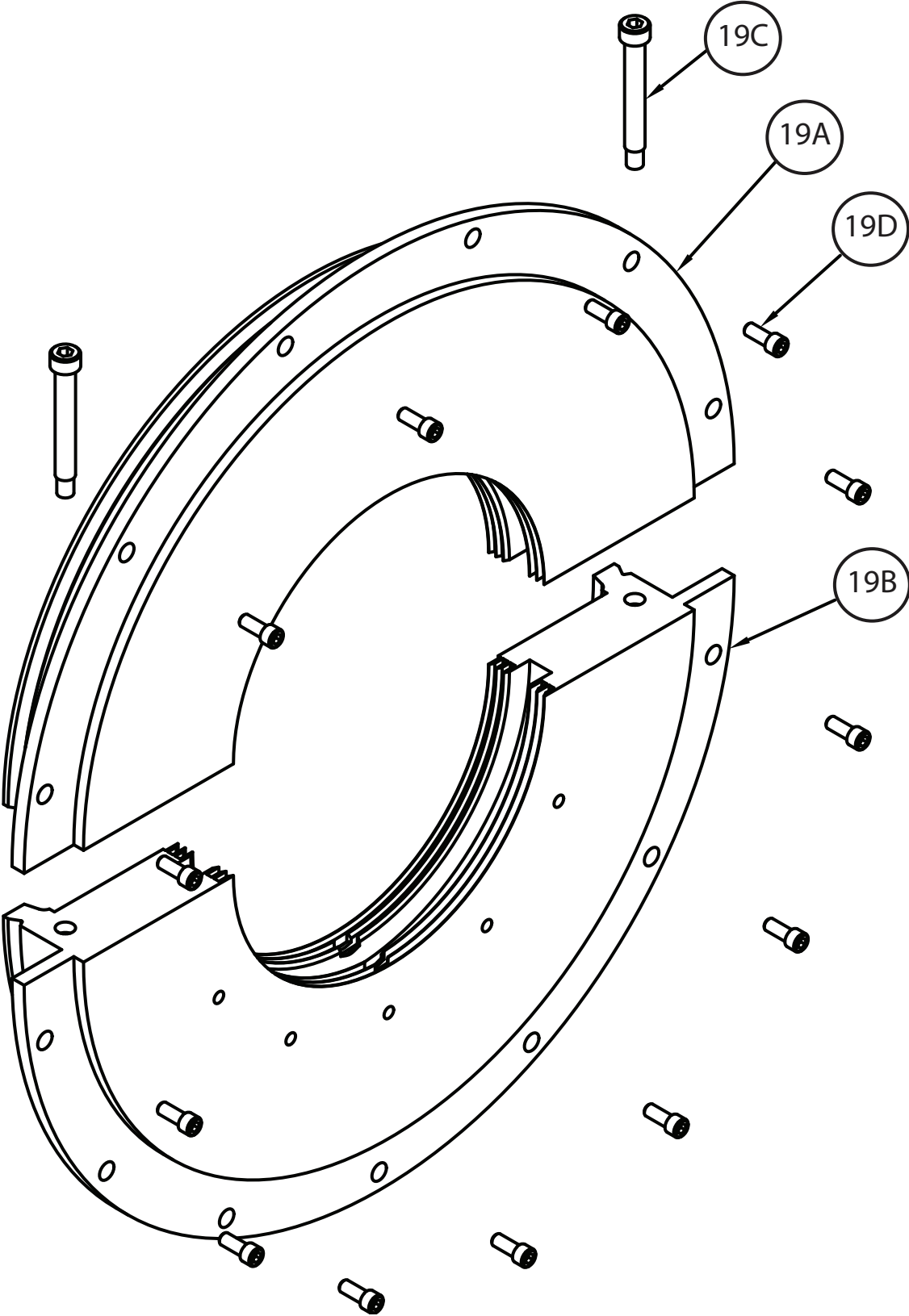

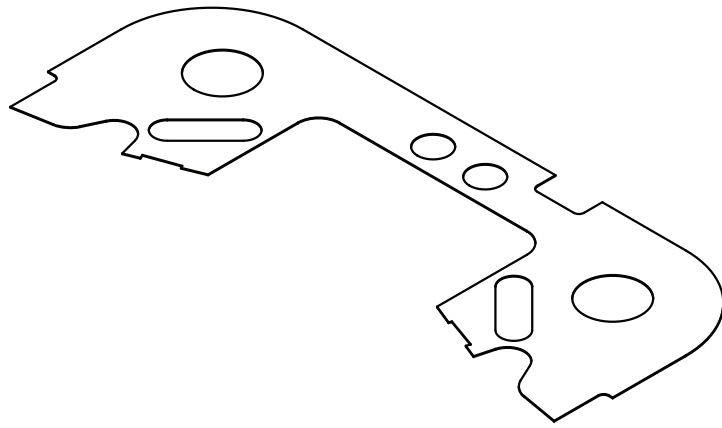

Shim

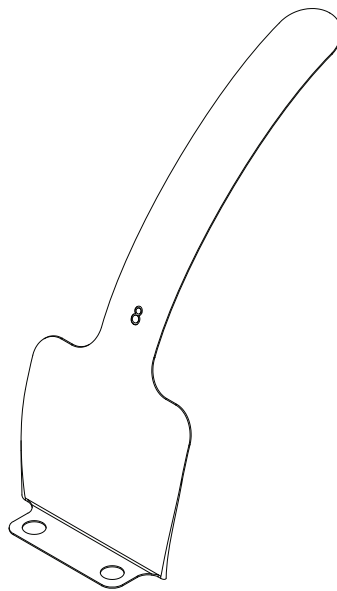

Collector Oil Leaf

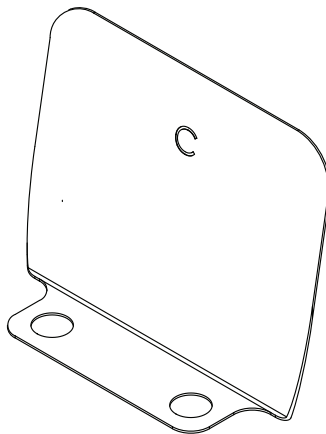

Oil Dam

Dodge Industrial, Inc.
1061 Holland Road
Simpsonville, SC 29681
+1 864 297 4800

