

Instruction Manual for Dodge® Sleeveoil® STL Pillow Blocks and Sleeveoil® SSL Pillow Blocks Sizes 3-15/16" through 8" PLXC

These instructions must be read thoroughly before installation or operation. This instruction manual was accurate at the time of printing. Please see dodgeindustrial.com for updated instruction manuals.

WARNING: To ensure the drive is not unexpectedly started, turn off and lock-out or tag power source before proceeding. Failure to observe these precautions could result in bodily injury.

WARNING: All products over 25 kg (55 lbs) are noted on the shipping package. Proper lifting practices are required for these products.

CAUTION: Do not scrape, rebabbitt or otherwise alter this product. Such action adversely affects bearing performance and may result in damage to or destruction of equipment.

WARNING: Because of the possible danger to person(s) or property from accidents which may result from the improper use of products, it is important that correct procedures be followed. Products must be used in accordance with the engineering information specified in the catalog. Proper installation, maintenance and operation procedures must be observed. The instructions in the instruction manuals must be followed. Inspections should be made as necessary to assure safe operation under prevailing conditions. Proper guards and other suitable safety devices or procedures as may be desirable or as may be specified in safety codes should be provided, and are neither provided by Dodge nor are the responsibility of Dodge. This unit and its associated equipment must be installed, adjusted and maintained by qualified personnel who are familiar with the construction and operation of all equipment in the system and the potential hazards involved. When risk to persons or property may be involved, a holding device must be an integral part of the driven equipment beyond the speed reducer output shaft.

Installation

The design of this pillow block allows the use of the PLXC liner. This is accomplished by using a "universal" grommet for the application. Complete pillow blocks are shipped in two packages, the housing and its associated parts are in one package and the liner in the other.



Figure 1 - Pillow Block components

Liners are shipped with pipes installed. If water cooling is not required, remove the pipes and install the vented plugs. Any optional accessories are packaged separately. Before mounting the pillow block read all instructions in this manual to become familiar with the mounting procedure and pillow block parts nomenclature. All instructions in this manual pertain to both standard (STL) and short series (SSL) pillow blocks with the exception of step 8 following which does not apply to SSL style bearings.

1. Check mounting structure making sure it is rigid, level and well supported. Inspect shaft to ensure it is smooth (32 micro-inch finish or better), free of burrs or rough spots, clean shaft in the bearing area. Standard shaft tolerance should be $+.000/-0.002$ on all sizes unless otherwise specified on shaft detail.
2. Disassemble and thoroughly clean all parts of the pillow block. Housing caps and liner caps are matched to their bases and are not interchangeable. Housings and liners can be interchanged as assemblies only.

CAUTION: Parts can be easily damaged. Liner assembly has critical machined surfaces which are easily damaged. Use care in handling to protect these surfaces. Liner parts should be placed on a soft, CLEAN surface.

CAUTION: Care should be taken when reinstalling coolant pipes to avoid bearing and liner damage. Over tightening may result in liner damage. Use pipe sealant and tighten securely.

- Position housing base on pedestal so that oil gage is in the position specified on the construction drawing. Also check construction drawings for special modifications on housing and/ or liner. **(Do NOT torque down housing base to pedestal.)** Apply oil to the spherical seats in the housing base. Because of the closely controlled liner to housing fit, it may be necessary to bolt the housing base down to allow the lower liner to slip into the housing seat in Step 4. Therefore, do a preliminary alignment check at this point (See Step 6).

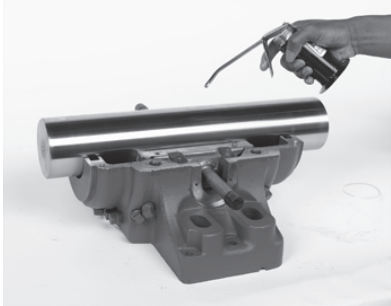

- Note location of thermocouple holes in liner base. Set liner base in housing base so that thermocouple holes in housing align with holes in liner. Thermocouple holes in housing base are opposite the side of housing marked "X."
- Apply oil to shaft in the bearing area and carefully set shaft in place. If the shaft is already supported in place, the liner can be rolled around the shaft into the housing seat. To do this, remove one of the water pipes from the liner base. Plug the water pipe hole with a clean rag to prevent contaminants from entering the housing. Apply oil to liner bearing surface and roll the liner around the shaft into place.

NOTE: Liner has been machined to close tolerances. Scraping of bore is not recommended.

It may be necessary to bolt housing base down to allow the liner to slip into the housing seat. Remove the rag and reinstall water pipe using pipe sealant.

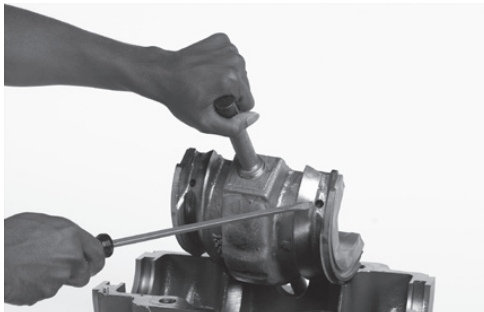

- Check alignment of pillow block by noting clearance

between housing and shaft at each end of the housing — clearance should be uniform within 1/32". Shim bearing pedestal where possible, otherwise use full length shims under base as required. Alignment of pillow block should be as accurate as possible. The self-alignment feature of the unit is to compensate for normal shaft deflection and possible settling of the supports.

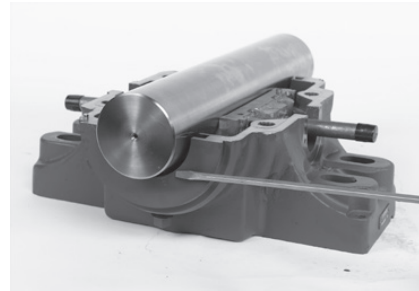

- Oil rings are shipped disassembled with 2 extra screws. Place oil rings around outside of liner base and over shaft.

NOTE: Oil ring halves are match-marked and MUST NOT be interchanged. Previous "T-Section" rings shown. "T-Section" oil rings should be replaced with upgraded "Trapezoidal Oil Rings". Part numbers are in parts list at end of manual.

Make sure rings rotate freely on shaft.

Install and tighten the four screws securely in each oil ring using low strength threadlocker.

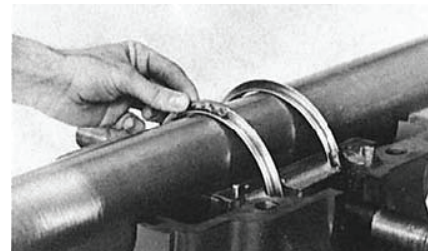

Step 8 does not apply to short series (SSL) style pillow blocks (and where integral collars are used). If integral collars are being used, refer to Dodge drawing B13540.

- FOR NON-EXPANSION BEARINGS ONLY: Thrust Collars** in a fixed unit, should now be installed. Remove clamp screws from thrust collars and clean cracked joint with wire brush. Back off set screws to clear inside of collar.

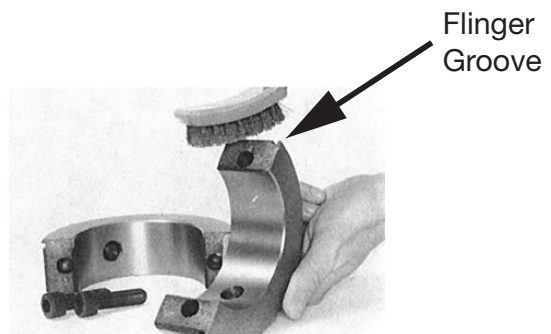

Place one collar half on shaft so that flinger groove is next to liner base in the non-expansion (fixed) bearing.

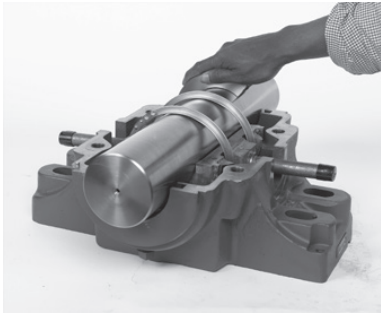

Rotate collar half around shaft and place other half in position. Bring halves together at joint, making sure match at joint is perfect, and insert clamp screws. There should be no offset at collar face. Tap halves together and torque clamp screws to value given in Table 1. Repeat this operation for opposite end of bearing.

NOTE: Assemble two collars on one bearing only.

Table 1 - Collar and Plunger Screw Torque Values

Standard Sleeveoil Size	Collar				Plunger Screw	
	Clamp Screw		Set Screw		Wrench Size (in-lbs)	Wrench Torque (in-lbs)
	Screw Size (Soc. Hex)	Wrench Torque (in-lbs)	Screw Size (Soc. Hex)	Wrench Torque (in-lbs)		
3-15/16	1/2-13NC	1425	3/4-10NC	1225*	3/8	850
4-7/16	1/2-13NC	1425	3/4-10NC	1225*	1/2	1250
4-15/16	1/2-13NC	1425	3/4-10NC	1225*	1/2	1250
5-7/16	1/2-13NC	1425	3/4-10NC	1225*	1/2	1250
6	5/8-11NC	2800	7/8-9NC	2450*	5/8	2500
7	5/8-11NC	2800	7/8-9NC	2870*	5/8	2500
8	3/4-10NC	5000	1-8NC	3500*	5/8	2500

*Torque values were decreased on thrust collar set screws in 2014.

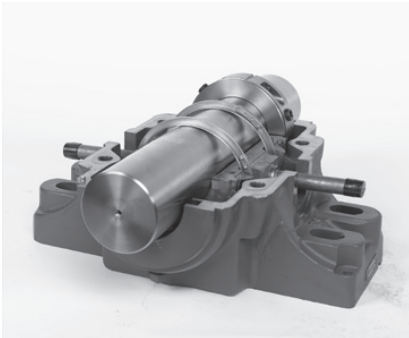

Tap collar up to face of liner allowing a total axial clearance of .008" to .014" on sizes 3-15 /16 and 4-7 /16, and .010" to .016" on sizes 4-15 /16" through 8".



Tighten (Soc. Hex) set screws on both collars to torque specified in Table 1. Collars should run parallel to end faces of liner within .002".

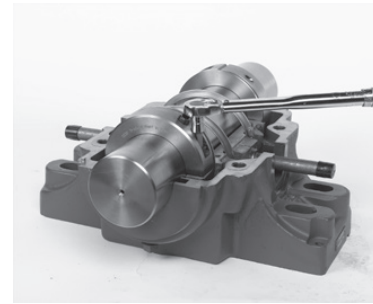

9. Apply oil to bearing surface of liner cap. Locate cap in place on lower liner making sure oil rings are in their cavities and are free to rotate.

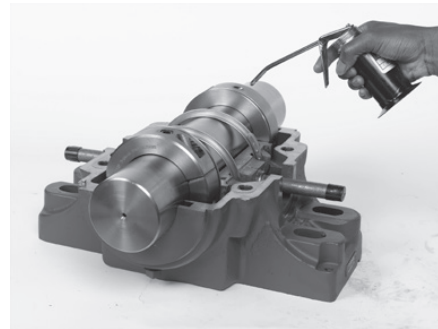

Install and torque liner cap screws to value given in Table 2.

NOTE: If liner cap does not seem to fit properly, ensure match marks are aligned and try again.

These SLEEVOIL liners have match marks permanently stamped at the joint near one end starting in June of 1988. These match marks permanently ensure parts stay paired and critical orientation of assemblies is maintained.

10. Tighten housing base to pedestal. Torque bolts to value given in Table 2.

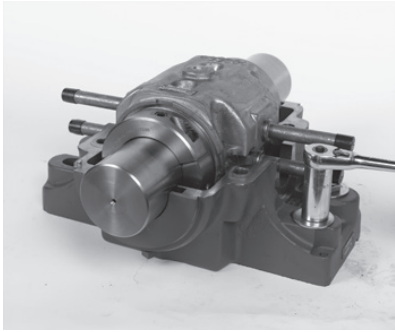
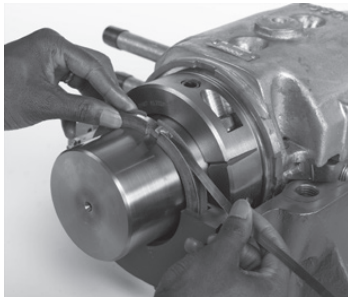

Table 2 - Housing Base Torque Values

Standard Sleeveoil Size	Liner Cap Screw		Housing Mounting Bolts	
	Screw Size	Torque (in-lbs)	Bolt Size	Torque (in-lbs)
3-15/16	5/16-18	132	7/8	2040
4-7/16	5/16-18	132	1	3000
4-15/16	3/8-16	240	1	3000
5-7/16	3/8-16	240	1-1/8	4200
6	1/2-13	600	1-1/4	6000
7	1/2-13	600	1-1/2	10000
8	1/2-13	600	1-3/4	11500

NOTE: Cork dust seals were replaced by HNBR dust seals in June 2012. New HNBR dust seals should be used in place of cork seals.

11. Apply oil to the inner diameter of the dust seal. Thread dust seal and seal retainer into groove at end of housing base and around shaft. Slide free end of seal retainer through clasp and pull tightly.



Hold clasp with screwdriver and pull free end of retainer tightly. After tightening, (the seal should move easily with light force). Cut off excess material.

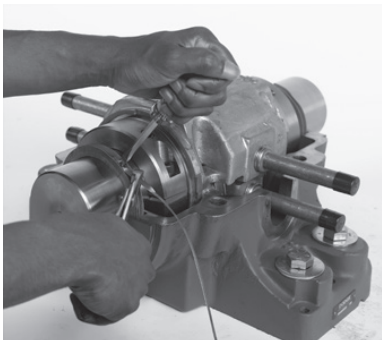

Aluminum seals, when specified for the application, are packaged separately. When using aluminum seals, discard standard (cork/HNBR) seals and seal retainers pack-aged with the housing. To install aluminum seals, wrap the O-ring (rubber cord) around the shaft in the seal area and cut it to fit the shaft. For most effective sealing, ends of O-ring must meet. Cementing the ends together is recommended. Disassemble one seal and place one half on shaft over the O-ring installed. Locate O-ring in seal groove and rotate seal half around shaft into housing base groove. Install other half of seal and tighten clamp screws to torque listed in Table 3. Install second seal in same manner. If using End Closure, install neoprene disc(s) at this time. Consult construction drawing for type of seal recommended.

12. We have replaced SLEEVOIL housing gaskets with 515 Gasket Eliminator. Apply Gasket Eliminator to SLEEVOIL housing base along outer contour of joint.

NOTE: Special care should be taken at grommet area.



Back off plunger screw and locate housing cap on base taking care not to damage dust seals or gasket material.

Apply RTV on a non-hardening sealant around each of the four housing bolt holes. This will prevent water from entering the bolt hole cavities.



These SLEEVOIL housings have match marks permanently stamped on the water pipe grommet pad starting in June of 1988. These match marks permanently ensure that parts stay paired and critical orientation of assemblies is maintained.

Cap Loaded Bearings: Only follow cap loaded tightening procedure on bearings that accept a vertical-upward load in over-hung (bearing-bearing-rotor) fan applications. For center hung (bearing-rotor-bearing) fan applications, proceed to the base loaded tightening procedure.

For cap loaded bearings, tighten the four cap bolts alternately to torque given in Table 3 while shaft is held down. The plunger screw should not be making contact with the liner when tightening cap bolts.

Loosen all four cap bolts one turn and loosen shaft hold down so that the shaft rests on the liner cap. This will allow the liner to self-align with the shaft.

Re-torque all four cap bolts alternately to values given in Table 3.

Remove shaft hold down.

Tighten the plunger screw to torque given in Table 1 and tighten plunger screw locknut.

NOTE: Do not tighten plunger screw on accompanying base loaded bearing until cap loaded bearing has been installed and hold down removed.



Base Loaded Bearings: Tighten the four housing cap bolts alternately to torque given in Table 3. **(Plunger screw should not be making contact with liner when tightening cap bolts.)**



Next tighten the plunger screw to torque given in Table 1 and tighten the plunger screw locknut. Wipe off any excess sealant and RTV/gasket material.

IMPORTANT: Check and re-torque plunger screw to the specified torque after 24 hours or initial start-up and then check periodically as required.

13. **Plain Liner Replacement:** When using a Plain Liner, remove pipes from PLXC liner assembly and install vent plugs, install grommet and grommet plate over openings in the sides of the housing. To reduce chances for oil leakage, a non-hardening sealant may be used.

Table 3 - Torque Values

Standard Sleeveoil Size	Housing Cap Bolts		Seal Clamp Screws	
	Bolt Size	Torque (in - lb)	Thread Size	Torque (in - lb)
3-15/16	3/4-10	1900	10-24	12
4-7/16	7/8-9	1700	10-24	12
4-15/16	7/8-9	1700	10-24	12
5-7/16	1-8	2600	1/4-20	33
6	1-8	2600	1/4-20	33
7	1-1/8-7	3600	5/16-18	65
8	1-1/8-7	3600	5/16-18	65

Externally Cooled Liner: XC liners can be air, water or oil cooled; check drawing for details. When PLXC Liners (with coolant pipes) are to be used, install grommet and grommet plate over pipes and tighten screws. Apply a non-hardening sealant to pipes, housing grommet area and between grommet and grommet plate to reduce chance of oil leakage. PLXC liners replace both older plain and XC styles.

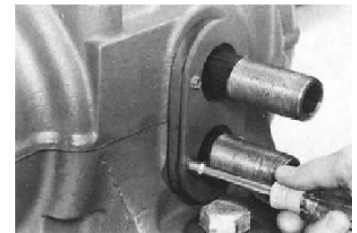

14. The oil level gauge may be located any distance from the pillow block by the use of a coupling and pipe of the desired length. The extended pipe must be supported so that it remains straight and perfectly level. Use a spirit level — do not guess. Use pipe sealer on all connections.

NOTE: If bearing is to be arranged for circulating oil, oil level gauge is not needed.

15. Remove all pipe plugs and flush liner bore and housing thoroughly with solvent or cleaner. Reinstall pipe plugs using pipe sealer. Tighten securely.
16. Check construction drawing and/or equivalent manual to determine if coolant pipes are to be connected. If no connection is required, pipes can remain open. Otherwise, make pipe connections required for coolant, making sure that all pipe lengths are correct and unions are well aligned. Careless fitting will result in serious pre-loading of bearing. Lengths of flexible hose between pillow block and rigid piping are recommended to avoid pre-loading of bearing. If water or glycol is used for coolant, the flexible hose can be of reduced size. Anti-freeze type additives may be used in cold operating environments, otherwise purge all coolant from liner by blowing out with compressed air or steam any time coolant is subject to freezing. Bearing rating is generally based on a maximum water inlet temperature of 90°F. A regulating valve should be placed ahead of the inlet and a sight drain at the outlet for liquid coolants. The recommended method of pipe connection for liquid coolants is to connect the inlet to one pipe and the outlet to the other pipe on the same side of the bearing. A return is then used to connect the two pipes on the other side of the bearings (See illustration). Adjust coolant flow rate specified on construction drawing or to suit conditions. When using air as the cooling medium, connect an inlet to each pipe on one side of the bearing and an outlet to the pipes on the other side.

Prior to placing the bearings into operation, check for cooling pipe leaks by placing the cooling water system into operation at normal operating pressure and flow rate. If a leak is detected, remove and reinstall the coolant pipes with pipe sealant and check again.

CAUTION: Do not stand on water pipes.

CAUTION: High air pressure may damage equipment. The fluid or air pressure should never exceed 120 PSI.

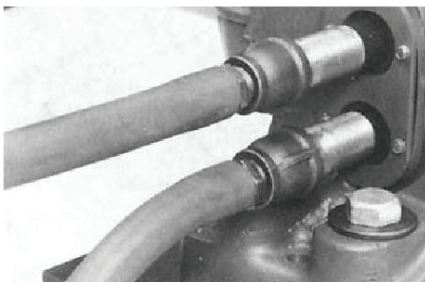
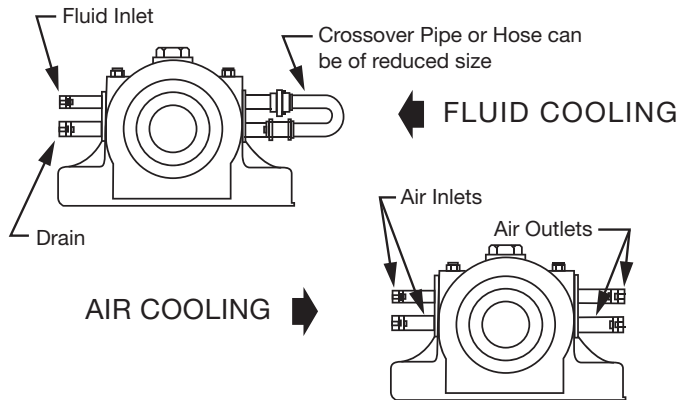

- 17. Each housing base has predrilled holes for doweling bearing to base plate.

Options

Thermocouple

A thermocouple is used to sense the temperature of the pillow block liner in the shaft area, and if a pre-set thermal limit is exceeded it can trigger a warning or, if desired, send a signal to disconnect electrical power to the motor.

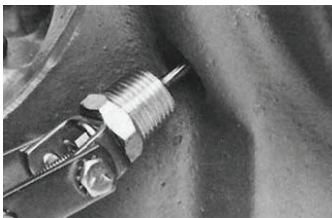

Two 1/2-14 N.P.S.F. threaded holes on the side opposite the "X" marking have been provided as a standard means of thermocouple mounting. Also furnished with the pillow block is a 1/2" x 1/8" adapter bushing to allow adaptation of thermocouples from several manufacturers. Spring loaded thermocouples are recommended for positive contact.

See page 10 for the thermocouple machining instructions.

Install the thermocouple in the location shown on the construction drawing. Make certain the probe extends into the liner thermocouple hole. For non-expansion bearing, the thermocouple should be located in the hole nearest to the end carrying the thrust load. When the direction of the thrust load is not known, two thermocouples are recommended. For expansion bearings, the thermocouple can be located at either end. Depending on thermocouple and bearing size it may be necessary to employ a system of pipe nipples and couplings to achieve proper probe penetration and housing clearance. Use sealant on all threaded connections including thermocouple mounting thread. Apply sealant to the pipe plug furnished and install it in the other hole.

Heater / Thermostat

An immersion heater is used to maintain a minimum oil temperature in the pillow block. If the pillow block has been machined for a heater and thermostat, the threaded mounting holes are usually located in the end face of the housing base. Install heater and thermostat using sealant on all threaded connections to prevent oil leakage.

NOTE: If coolant temperature can fluctuate below 70°F during low ambient conditions, then an oil sump heater/thermostat should be installed to ensure proper oil temperature is maintained.

CAUTION: Heater can be damaged. Turn off heater before filling or drawing oil from pillow block. Heater will overheat when not submerged in oil.

WARNING: Risk of shock. When installing heater/thermostat, follow directions and safety procedures recommended by the manufacturer. Install wiring in accordance with the National Electric Code and local codes.

Circulating Oil

When pillow block is arranged for circulating oil, a circulating oil inlet kit is required.

Description	Part Number
3-15/16 Circulating Oil Inlet Kit	432153
4-7/16 – 4-15/16 Circulating Oil Inlet Kit	430198
5-7/16 – 8 Circulating Oil Inlet Kit	430155

If the housing has been arranged for circulating oil, the inlets are located in the housing cap. Pipes extend through the housing cap and are directed toward the inspection holes in the liner. Consult manufacturer's drawing for exact dimensions and location of drain(s).

Install oil supply lines to the 1/4" N.P.T. external (male) threaded inlets so that each inlet will receive an equal amount of oil. Make sure that the oil flows from the pipes directly into the inspection holes. Drain piping should be vented and of maximum size to drain oil from the bearing at the specified flow rate. The housing drain must be directed straight down into a return drain sloping away at a 15 degree or greater angle from the horizontal. The oiling system must have a means of filtering the oil to remove any contaminating particles. A 25 micron filter or better is recommended.



Fill the pillow block with oil to the top of the center circle in the oil gauge.

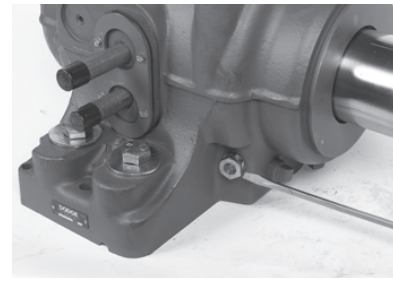

NOTE: Isolators or Auxiliary seals are recommended for outdoor applications, contaminated atmospheres, and high volume air flowing over the bearing.

NOTE: Bearings should NOT be stored outdoors before installation. For extended or outdoor storage, contact equipment manufacturer for special storage instructions.

NOTE: Bearings (and shafts) allowed to sit idle for extended periods after being run MUST be protected against corrosion. If the unit can not be run for several minutes at least once a week, consult equipment manufacturer for special lubrication instructions.



After placing into operation, remove inspection covers and check to make sure oil rings are bringing up oil. Operation should be checked frequently during the first few days. After some running of base loaded bearings only, loosen plunger screw 1/4 turn, then retighten to specified torque. This will allow the liner to align with the shaft. For cap loaded bearings, follow installation procedure. If noise develops, check alignment of housing, collar runout, plunger screw and all operating parts. Check all points and make sure all screws and nuts are tightened after several days operation. Maintain oil level between center and top of oil gauge at all times while unit is in operation.

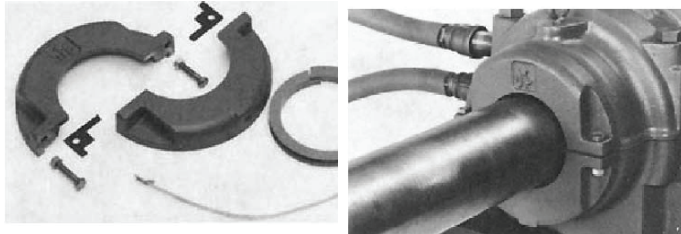

End Closure Kits and Auxiliary Seal Kits are available and may be added at any time without any machining to the pillow block. Refer to the instructions packaged with the kits for installation details.

Lubrication and Operation

Since the satisfactory operation of the pillow block depends almost entirely on the oil film being maintained between the shaft and liner bearing surface, it is recommended that a high grade straight mineral oil with rust and oxidation (R & O) inhibitors and anti-foam agents be used. Check equipment specifications for specific recommendation of oil viscosity by equipment manufacturer. Information regarding qualities and properties of specific oils should be referred to the lubricant manufacturer.

NOTE: The recommended oil temperature at start-up is 70°F MINIMUM.

Oil film temperature in liners during normal operation should not exceed 180°F. If in doubt, consult equipment manufacturer.

Low ambient and operating temperatures can be as harmful to the bearing as high temperatures. A heater and thermostat would be required for such applications.

Oil Maintenance Schedule

Drain, flush, and refill with oil after 2 to 3 weeks of initial break-in operation. Since the satisfactory operation of the bearing depends entirely on an oil film being maintained between the shaft and the bearing liner surface, it is recommended that an oil analysis be performed at these regular intervals.

- Every 3 months for 24 hour/day service
- Every 6 months for 8 hour/day service

Acceptability of oil should be referred to the lubricant manufacturer. If oil quality is acceptable then repeat this procedure in 3 month intervals. Visually check oil for contamination between oil analysis checks. Oil service life depends upon several factors such as ambient conditions, operating temperature and frequency of bearing starts and stops. It is recommended that the oil be changed at least once per year for unfiltered static applications. Removing contaminants through the use of either the OLF (Oil Level and Filtration) Unit or a circulating oil system can extend oil service life. Consult equipment manufacturer for more information.

Check construction drawing for proper coolant flow rate. If the coolant inlet temperature exceeds 90°F additional coolant will be required.

Any questions on installation, maintenance or operation should be referred to the equipment manufacturer.

Pillow Block Material Details

Housing:	Class 30 Gray Cast Iron
Liner:	Class 30 Gray Cast Iron
Babbitt:	Lead or Tin Based Babbitt
Oil Rings:	Bronze
Seal:	HNBR with Stainless Steel Retainer
Aux. Seal:	HNBR with Stainless Steel Retainer
Grommet:	Synthetic Rubber
Grommet Plate:	Carbon Steel
Pipe Nipple:	Carbon Steel
Oil Gauge:	Stainless Steel, Polypropylene
Hardware:	Carbon Steel
Plunger Screw:	Carbon Steel
Gasket Eliminator:	LOCTITE 515 Sealant

This Sleeveoil pillow block could contain lead in the bearing Babbitt material, please exercise proper precautions in the use, installation, dismantling and recycling of this unit.

Other Notes:

CAUTION: This product is not to be used for person moving applications.

NOTE: Care has been taken to keep instruction manuals accurate and timely. The most recent version of the instruction manual can be found on our website: www.dodgeindustrial.com

Weights

Table 4 - Weights

PLXC SLEEVOIL Size	Approximate Weights (lbs.)			Liner Assembly
	Non-Expansion Pillow Block (STL)	Expansion Pillow Block (STL)	Expansion Pillow Block (SSL)	
3-15/16	215	201	193	54
4 7/16	287	271	255	71
4-15/16	385	362	324	92
5-7/16	495	470	462	130
6	629	598	570	158
7	944	882	845	230
8	1395	1298	1256	375

Table 5 - Flow Rate

Pillow Block Size	Oil Volume ^①		
	Fl. Oz. ②	Quarts. Approximate. ②	Liters Approximate. ②
3-15/16	50	1-1/2	1.45
4-7/16	64	2	1.90
4-15/16	90	2-3/4	2.70
5-7/16	100	3-1/8	2.95
6	132	4-1/8	3.90
7	240	7-1/2	7.10
8	320	10	9.50

① Volume of oil required to fill pillow block to top of center circle in oil gage. Applies to both XC and Plain Pillow Blocks.

② 32 fl. oz. = 1 quart = 94636 liters.

These SLEEVOIL pillow blocks and liners have nameplates attached starting in June 1988 identified by a six-digit part number which fully identifies the housing and/or liner. Liner nameplates are pinned to the SLEEVOIL liner cap near an oil ring inspection hole. Housing nameplates are pinned to the housing foot parallel to the shaft. Refer to these part numbers when ordering replacement parts.

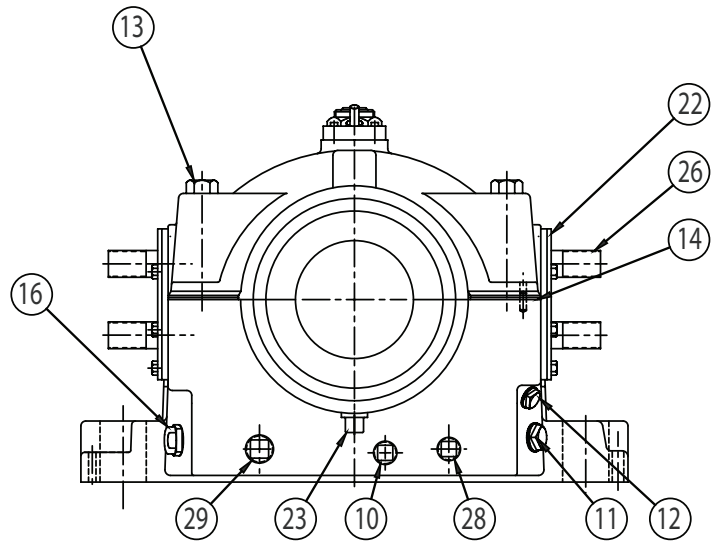
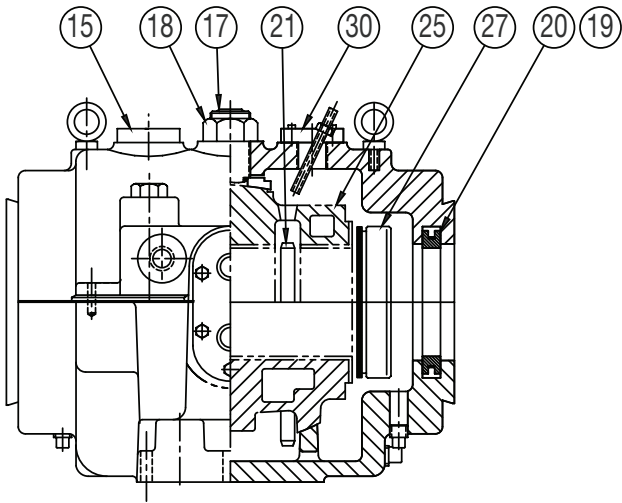

PLXC STL Pillow Block

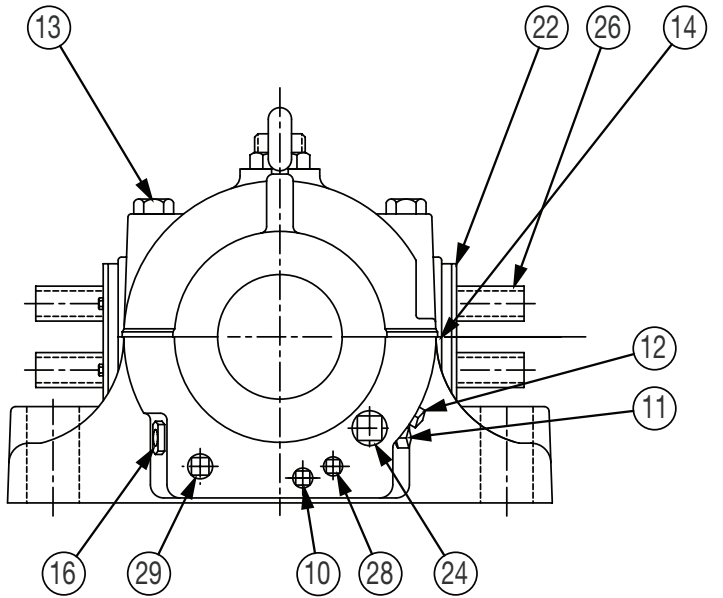
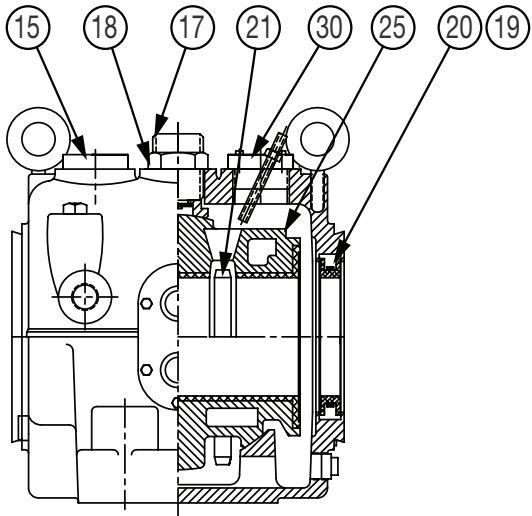

PLXC SSL Pillow Block

BEARING SIZE	A	B	C	D	E	F	*G	H	J	*K
3-7/16	3-1/2	20°	7/8	1/4	2-3/8	60°	3-1/4	2	2-1/2	5-5/16
3-15/16	4-7/64	20°	1-3/32	1/4	2-23/32	60°	3-9/32	2	3-1/2	6-3/8
4-7/16	4-13/16	20°	1-13/16	5/16	2-31/32	60°	3-11/16	1-1/4	3	6-7/32
4-15/16	5-9/32	20°	1-13/16	5/16	3-5/16	60°	3-31/32	1-1/4	4	7-1/2
5-7/16	5-11/16	20°	1-13/32	5/16	3-21/32	60°	4-15/32	9/16	3	6-31/32
6	5-63/64	20°	1-7/32	5/16	3-29/32	60°	4-27/32	3/8	3-1/2	7-7/8
7	6-7/8	20°	49/64	5/16	4-21/32	60°	5-21/32	1/4	3	8-5/32
8	8-3/32	20°	23/32	5/16	5-13/32	60°	6-1/2	1-3/16	2	8-1/32

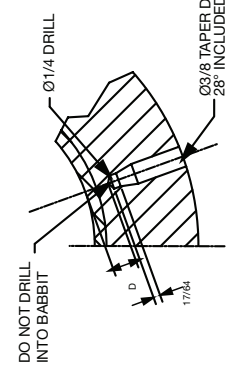

ENLARGED VIEW SHOWING LOCATION OF TAPER DRILL

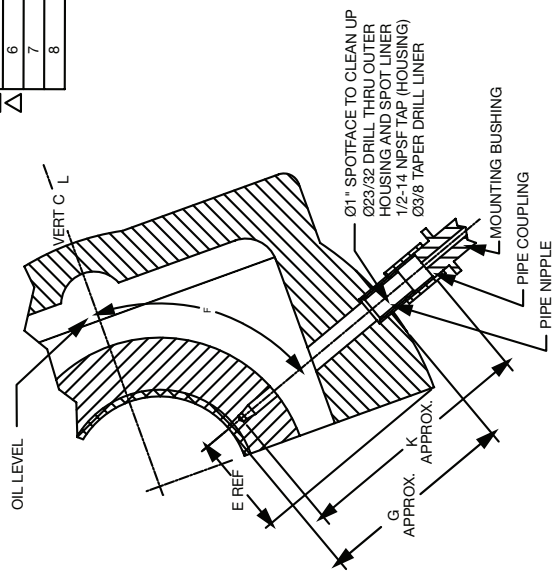

SECTION X-X

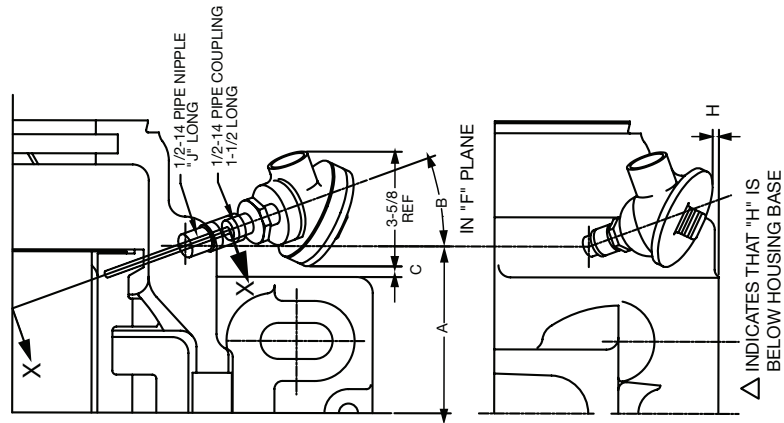

△ INDICATES THAT "H" IS BELOW HOUSING BASE

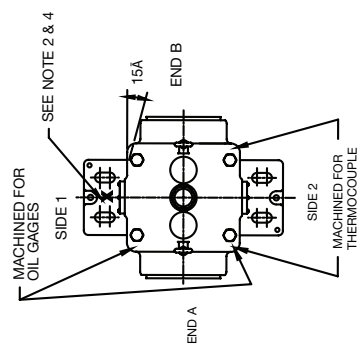

- NOTES:
- * 1. THESE ARE MEAN DIMENSIONS, TIP SENSITIVE SPRING LOADED OR ADJUSTABLE THERMOCOUPLES RECOMMENDED.
 2. FOR 3-15/16 THRU 14" LINERS, MACHINE BOTH ENDS OF EITHER SIDE UNLESS MODIFIED FOR A PARTICULAR ROTATIONAL DIRECTION.
 3. THERMOCOUPLES TO BE MACHINED ON SIDE OPPOSITE "X" ON HOUSING FOOT.

Sleevoil STL and SSL Pillow Blocks

Item	Description	Number Required	Replacement Part Numbers						
			3-15/16"	4-7/16"	4-15/16"	5-7/16"	6	7	8
③	STL PLXC Expansion Pillow Block ① ②	1	134200	134201	134202	134203	134204	134205	134206
	STL Modular Housing Assembly	1	132782	132783	132784	132688	132689	132690	132691
③	SSL PLXC Expansion Pillow Block ① ②	1	134207	134208	134209	134210	134211	134212	134213
	SSL Modular Housing Assembly	1	132718	132719	132720	132920	132921	132922	132923
25	PLXC Liner Assembly ① ④	1	132952	132953	132954	132955	132956	132957	132958
26	Coolant Pipe	4	430171	430171	430174	430174	430176	430176	430177
③	Dowel Pin	2	420053	420053	420064	420064	420080	420080	420080
③	Liner Cap Screw	2	417084	417084	417117	417114	417184	417184	417184
③	Vented Plug Kit	1	462996	462996	462997	462997	462997	462997	462997
27	Thrust Collar (STL Only) ⑤	2	133285	133292	133293	133294	133295	133296	133297
21	Trapezoidal Oil Ring	2	135290	135291	135292	135293	135294	135136	135296
17	Plunger Screw Kit ①	1	435012	435021	435021	435013	435015	435016	435016
③	Plunger Screw	1	—	—	—	—	—	—	—
③	Plunger Screw Bushing	1	—	—	—	—	—	—	—
③	Plunger Screw Washer	1	—	—	—	—	—	—	—
18	Plunger Screw Locknut	1	—	—	—	—	—	—	—
20	Dust Seal Kit ①	1	389828	389829	389830	389831	389832	389833	389834
19	Dust Seal	2	—	—	—	—	—	—	—
③	Seal Retainer	2	—	—	—	—	—	—	—
③	Gasket Eliminator	Varies	427359	427359	427359	427359	427359	427359	427359
22	Grommet Kit ① ⑦	1	435033	435033	435034	435034	435035	435035	435036
26	Rubber Grommet	2	—	—	—	—	—	—	—
③	Grommet Plate	2	—	—	—	—	—	—	—
	Hex Head Screw	8	—	—	—	—	—	—	—
	Coolant Pipe	4	430171	430171	430174	430174	430176	430176	430177
	Gasket Eliminator	Varies	427359	427359	427359	427359	427359	427359	427359
10	Drain Plug	1	430012	430012	430012	430012	430012	430012	430012
11	Oil Level Plug	1	430012	430012	430012	430014	430014	430014	430014
12	Thermocouple Plug	2	430012	430012	430012	430012	430012	430012	430012
③	Thermocouple Adapter	1	430081	430081	430081	430081	430081	430081	430081
13	Housing Bolt	4	411190	411196	411197	411205	411207	411226	411227
15	Inspection Cover	2	432197	432199	432199	432199	432199	432199	432199
16	Oil Gage	1	430139	430139	430139	430135	430135	430135	430135
23	Circulating Oil Drain Plug (STL Only)	2	430014	430014	430016	430016	430016	430017	430017
24	Circulating Oil Drain Plug (SSL Only)	2	430014	430016	430017	430017	430017	430017	430017
28	Accessory / Thermometer Plug	1	430012	430012	430012	430012	430012	430012	130012
29	Heater Thermostat Combo Plug	1	430014	430014	430014	430014	430016	430016	430017
Optional Accessories									
③	Auxiliary Seal Kit ⑥	2	432181	432184	432187	133932	133933	133937	133938
③	Sleevoil Isolator	2	434707	434708	434709	434710	434711	434712	434713
③	Housing End Cap Kit ⑥	1	432190	432193	432196	132546	132547	132548	132549
30	Circulating Oil Inlet Kit	1	432153	430198	430198	430155	430155	430155	430155
③	Vibration Detector Adapter Kit	1	430153	430153	430153	430153	430153	430153	430153
③	Coolant Hose Kit	1	434771	434771	434772	434772	434772	434772	434772
③	110V Heater / Thermostat Combo	1	434721	434721	434721	434721	434725	434725	434727
③	220V Heater / Thermostat Combo	1	434722	434722	434722	434722	434726	434726	434728
③	Oil Sump Thermometer	1	435093	435093	435093	435093	435093	435093	435093
③	RTD Kit	1	435147	435147	435147	435147	435147	435147	435147

① These parts are assemblies and include the parts listed directly below them (included parts are indented on table).

② Pillow Blocks include the Modular Housing, Liner Assembly, and all items shown with the exception of Thrust Collars and Optional Accessories

③ Not shown on drawing.

④ Liner Assemblies are PLXC style. These liners will work in plain, water, oil, or air cooled applications. Due to the coolant pipe size, PLXC liners will not fit in housings manufactured prior to 1973; consult factory if necessary. Replacement WC (pre-1973) liners are available for pre-1973 housings. (Part numbers not shown; consult catalog or Mechanical Power Transmission Support for assistance.)

⑤ Two required to turn an expansion STL bearing into a non-expansion bearing. Includes all hardware required for mounting. Cannot be used with SSL style Pillow Blocks.

⑥ Bearings can potentially use two Auxiliary Seal Kits or a combination of one Auxiliary Seal Kit and one End Cap Kit. Both items will add length to the bearing housing.

⑦ WC (pre-1973) housings require WC housing grommets (not listed). Consult Mechanical Power Transmission Support for assistance.

Sleevoil Accessories

The following accessories are available for Sleeveoil bearings to enhance operation and extend bearing life. For compatibility and technical information contact Mechanical Power Transmission support.

OIL LEVEL AND FILTRATION (OLF-2) SYSTEM



- Increase bearing longevity and reliability.
- One OLF-2 system supplies two bearings with a continuous flow of filtered oil.
- The oil is supplied directly to the circulating oil inlets on the bearings, which helps minimize wear during startups and shutdowns.
- Reference instruction manual MN3079.

COOL LUBE 2

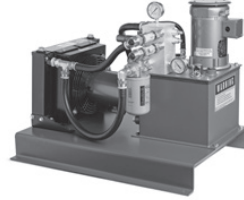

- All the features of the OLF-2 system plus a built-in heat exchanger for continuous oil cooling and adjustable oil flow controls.
- Particularly well suited in applications where bearing operating temperatures and speeds approach the maximum permissible levels.
- Reference instruction manual MN3082.

DODGE SLEEVOIL BEARING ISOLATOR



- Fully split multi-labyrinth sealing system.
- Provides outstanding protection in harsh and dirty environments.
- IP56 rated
- Reference instruction manual MN3077.

HEATER/THERMOSTAT



- The bearing sump heater and thermostat have been combined into one user-friendly unit.
- Sump heaters are a necessity to ensure safe startups when bearings are exposed to ambient temperatures below 70°F.
- Reference instruction manual MN3078.

RTD KIT



- Prevent catastrophes by accurately measuring bearing temperature.
- Features a field-cuttable stainless steel probe, a platinum sensing element and a spring-loaded fitting with an oil seal.
- Part Number 435147.

COOLANT HOSE KIT



- An easy to install solution for connecting coolant lines to your Sleeveoil bearing.
- Durable flexible hoses are composed of a synthetic rubber inner tube reinforced with fiber and steel braids.

Dodge Industrial, Inc.
1061 Holland Road
Simpsonville, SC 29681
+1 864 297 4800



* 3 0 5 7 - 0 2 2 2 *