

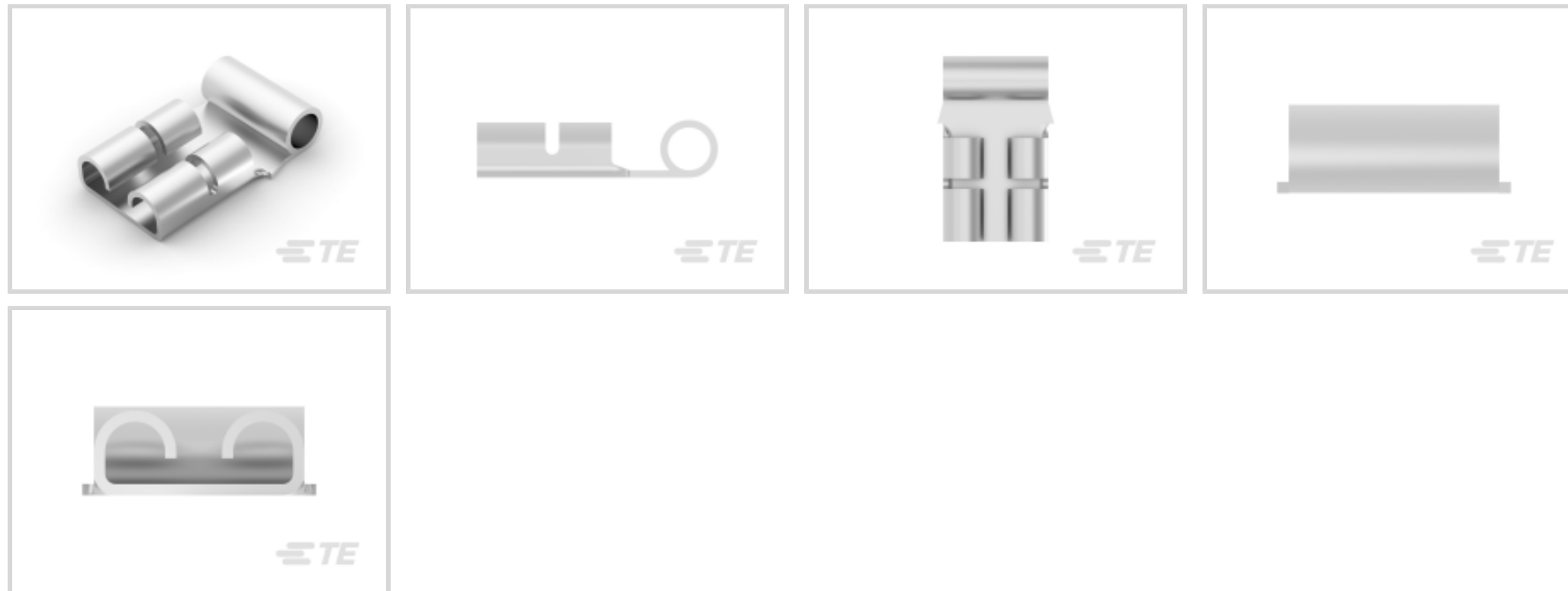

Terminals & Splices > Quick Disconnects



Terminal & Splice Type: **Receptacle**

Mating Tab Width: **6.35 mm [.25 in]**

Mating Tab Thickness: **.81 mm [.032 in]**

Terminal Orientation: **Flag**

Fully Insulated: **No**

Features

Product Type Features

Terminates To	Wire & Cable
Sealable	No
Insulated	No

Body Features

Fully Insulated	No
Plating Material	Tin

Contact Features

Terminal & Splice Type	Receptacle
Terminal Orientation	Flag
Contact Base Material	Brass
Crimp Type	F-Crimp
Barrel Type	Open

Mechanical Attachment

Wire Insulation Support	Without
-------------------------	---------

Dimensions



Receptacle Terminal Stock Thickness	.41 mm[.016 in]
-------------------------------------	-----------------

Mating Tab Width	6.35 mm[.25 in]
------------------	-----------------

Mating Tab Thickness	.81 mm[.032 in]
----------------------	-----------------

Usage Conditions

Operating Temperature Range	-40 – 110 °C[-40 – 230 °F]
-----------------------------	----------------------------

Packaging Features

Packaging Method	Loose Piece/Carton
------------------	--------------------

Product Compliance

[For compliance documentation, visit the product page on TE.com>](#)

EU RoHS Directive 2011/65/EU	Compliant
------------------------------	-----------

EU ELV Directive 2000/53/EC	Compliant
-----------------------------	-----------

China RoHS 2 Directive MIIT Order No 32, 2016	No Restricted Materials Above Threshold
---	---

EU REACH Regulation (EC) No. 1907/2006	Current ECHA Candidate List: JAN 2019 (197) Candidate List Declared Against: JAN 2019 (197)
--	--

Halogen Content	Low Halogen - Br, Cl, F, I < 900 ppm per homogenous material. Also BFR/CFR/PVC Free
-----------------	---

Solder Process Capability	Not applicable for solder process capability
---------------------------	--

Product Compliance Disclaimer

This information is provided based on reasonable inquiry of our suppliers and represents our current actual knowledge based on the information they provided. This information is subject to change. The part numbers that TE has identified as EU RoHS compliant have a maximum concentration of 0.1% by weight in homogenous materials for lead, hexavalent chromium, mercury, PBB, PBDE, DBP, BBP, DEHP, DIBP, and 0.01% for cadmium, or qualify for an exemption to these limits as defined in the Annexes of Directive 2011/65/EU (RoHS2). Finished electrical and electronic equipment products will be CE marked as required by Directive 2011/65/EU. Components may not be CE marked. Additionally, the part numbers that TE has identified as EU ELV compliant have a maximum concentration of 0.1% by weight in homogenous materials for lead, hexavalent chromium, and mercury, and 0.01% for cadmium, or qualify for an exemption to these limits as defined in the Annexes of Directive 2000/53/EC (ELV). Regarding the REACH Regulations, TE's information on SVHC in articles for this part number is still based on the European Chemical Agency (ECHA) 'Guidance on requirements for substances in articles' (Version: 2, April 2011), applying the 0.1% weight on weight concentration threshold at the finished product level. TE is aware of the European Court of Justice ruling of September 10th, 2015 also known as O5A (Once An Article Always An Article) stating that, in case of 'complex object', the threshold for a SVHC must be applied to both the product as a whole and simultaneously to each of the articles forming part of its composition. TE has evaluated this ruling based on the new ECHA "Guidance on requirements for substances in articles" (June 2017, version 4.0) and will be updating its statements accordingly.

Also in the Series | **FASTON 250**



Compression Connectors
(4)

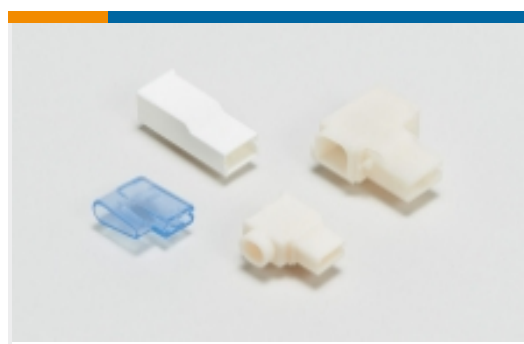

Crimp Terminal Housings
(126)



Insulation Boots & Sleeves
(16)



Magnet Wire Terminals(1)



PCB Terminals(136)



Quick Disconnects(464)



Splices(4)

Customers Also Bought



TE Part #1438246-2
SPLICE, BUTT, HEATER
WIRE 18-16AWG PTPBR



TE Part #1601599-1
L061/076C16TB=RTM
1100-3200



TE Part #1-480705-1
06P UMNL CAP HSG BRN



TE Part #31181
TERMINAL,BODY FLAG R
16-14 10



TE Part #1217296-1
RCPT250 F&RCPT094PIN
BENT TPBR

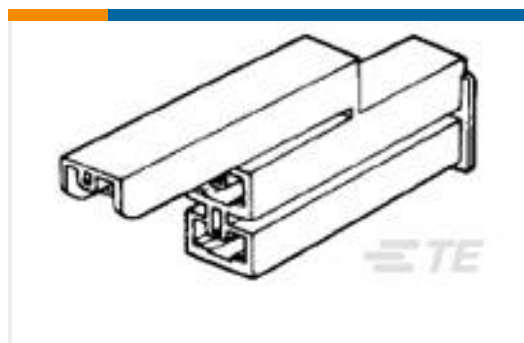

TE Part #172075-4
POSITIVE LOCK 187
HOUSING RECEPTACLE



TE Part #42373-3
FASTON 187 16-20AWG
NPST

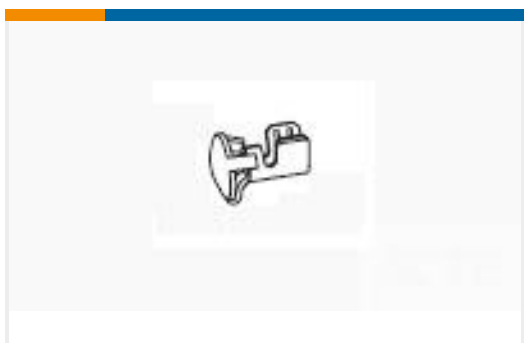

TE Part #61280-1
BUTTON CONTACT 20-16
AWG BR



TE Part #735014
SLEEVE 375 NAT

Documents



CAD Files

3D PDF

3D

Customer View Model

[ENG_CVM_CVM_1217295-1_G.2d_dxf.zip](#)

English

Customer View Model

[ENG_CVM_CVM_1217295-1_G.3d_igs.zip](#)

English

Customer View Model

[ENG_CVM_CVM_1217295-1_G.3d_stp.zip](#)

English

Product Specifications

Application Specification

English

Wire Preparation And Crimp Inspection Guide

English