

SW2015

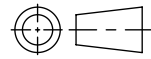

| Revision level |                |      | Revision Record | Changed | Date      | Approved | Date      |
|----------------|----------------|------|-----------------|---------|-----------|----------|-----------|
| Drawing        | State          | Part |                 |         |           |          |           |
| 00.0           | Design Release |      | SEE ECN# 014308 | CAS     | 2/14/2018 | KAC      | 2/14/2018 |

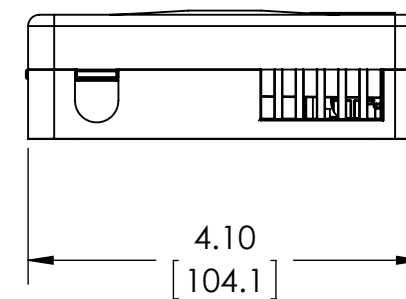
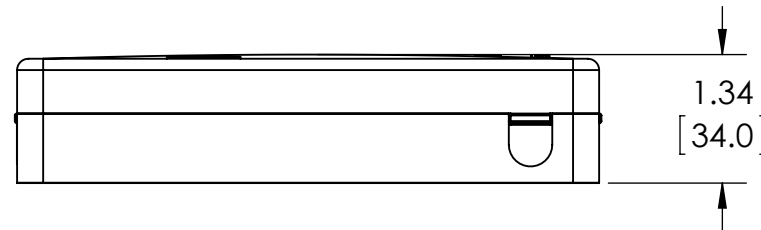
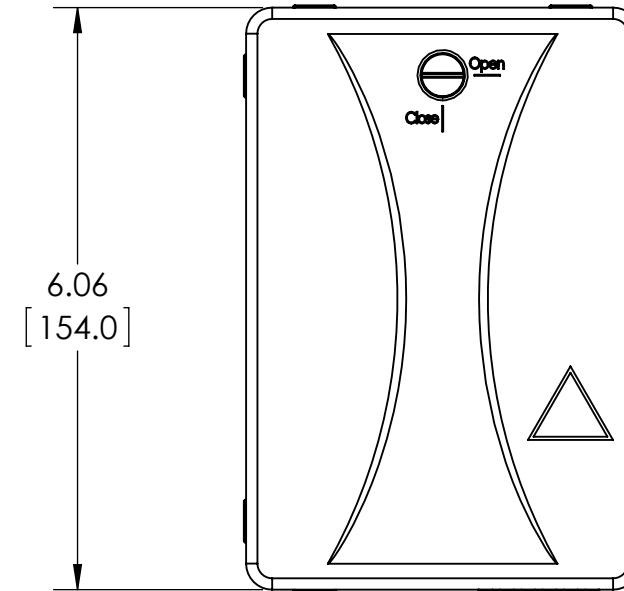
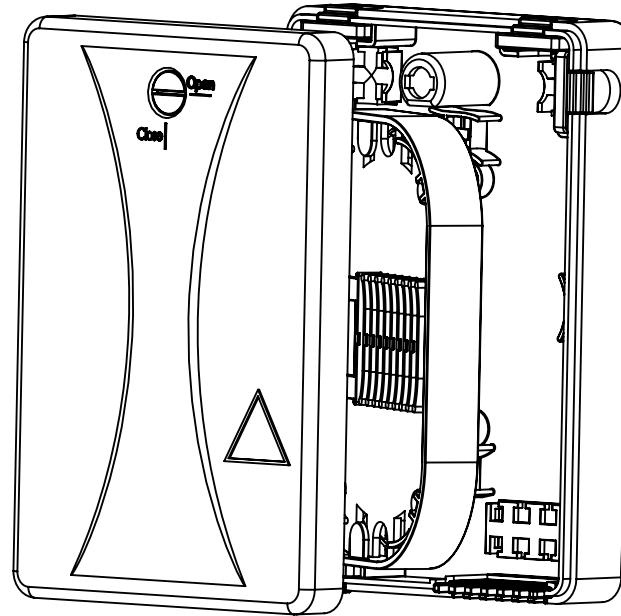

|                                    |                    |
|------------------------------------|--------------------|
| <b>Maximum Number of Splices</b>   | 18 (45mm long max) |
| <b>Color</b>                       | White              |
| <b>Material</b>                    | ABS                |
| <b>Cable Entrance Ports (Side)</b> | 6                  |

|       |                       |   |   |  |     |           |                           |                    |  |                |            |
|-------|-----------------------|---|---|--|-----|-----------|---------------------------|--------------------|--|----------------|------------|
| Notes | Material<br>ASSEMBLED | Units: inches<br>Dimension without tolerances details to:<br>.xxxx = ±.0005<br>.xxx = ±.005<br>.xx = ±.01<br>.x = ±.03<br>None = ±.06<br>∠ = ±0.5°<br>Dimension Formatted in/[mm] | The copyright of this drawing is reserved by HellermannTyton. It is issued on condition that it is not reproduced, copied, or disclosed to a third party, either wholly or in part, without the consent of HellermannTyton. | Drawn  | CAS | 2/14/2018 | Article/Type-No<br>FDES-E | Scale              | 1:2  |                |            |
|       |                       |   |   | Approved   | KAC | 2/14/2018 |                           | Title              | Fiber Distribution Enclosure, Indoor Splice Only | Project Number | PRP18-0362 |
|       |                       |   |   | North America<br>Email: corp@htamericas.com<br>Web: www.hellermann.tyton.com |     |           | Drawing-No                | PRODUCTION : Phase |  | Format         | B          |
|       |                       |   |   |  |     |           | <b>18-0362-001-CSU</b>    |                    |  | Sheet          | 1/1        |