

INA20x –16-V to 80-V, 500-kHz Current Sense Amplifier With Dual Comparators

1 Features

- Complete current sense solution
- Three gain options available:
 - INA203 = 20 V/V
 - INA204 = 50 V/V
 - INA205 = 100 V/V
- Dual comparators:
 - Comparator 1 with latch
 - Comparator 2 with optional delay
- Common-mode range: –16 V to 80 V
- High accuracy: 3.5% (maximum) over temperature
- Bandwidth: 500 kHz
- Quiescent current: 1.8 mA
- Packages: SO-14, TSSOP-14, VSSOP-10

2 Applications

- Notebook computers
- Cell phones
- Telecom equipment
- Automotive
- Power management
- Battery chargers
- Welding equipment

3 Description

The INA203, INA204, and INA205 are a family of unidirectional current-shunt monitors with voltage output, dual comparators, and voltage reference. The INA203, INA204, and INA205 can sense drops across shunts at common-mode voltages from –16 V to 80 V. The INA203, INA204, and INA205 are available with three output voltage scales: 20 V/V, 50 V/V, and 100 V/V, with up to 500-kHz bandwidth.

The INA203, INA204, and INA205 also incorporate two open-drain comparators with internal 0.6-V references. On 14-pin versions, the comparator references can be overridden by external inputs. Comparator 1 includes a latching capability, and Comparator 2 has a user-programmable delay. 14-pin versions also provide a 1.2-V reference output.

The INA203, INA204, and INA205 operate from a single 2.7-V to 18-V supply. They are specified over the extended operating temperature range of –40°C to 125°C.

Device Information (1)

PART NUMBER	PACKAGE	BODY SIZE (NOM)
INA203, INA204, INA205	SOIC (14)	8.65 mm × 3.91 mm
	VSSOP (10)	3.00 mm × 3.00 mm
	TSSOP (14)	5.00 mm × 4.40 mm

(1) For all available packages, see the orderable addendum at the end of the data sheet.

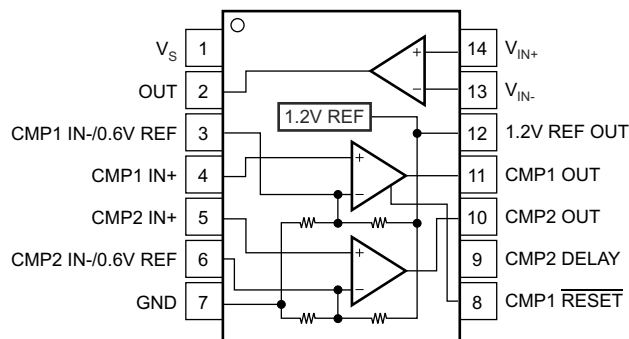

Simplified Schematic



Table of Contents

1 Features	1	7.3 Feature Description.....	14
2 Applications	1	7.4 Device Functional Modes.....	18
3 Description	1	8 Application and Implementation	22
4 Revision History	2	8.1 Application Information.....	22
5 Pin Configuration and Functions	4	8.2 Typical Application.....	22
6 Specifications	5	9 Power Supply Recommendations	23
6.1 Absolute Maximum Ratings.....	5	10 Layout	24
6.2 ESD Ratings.....	5	10.1 Layout Guidelines.....	24
6.3 Recommended Operating Conditions.....	5	10.2 Layout Example.....	24
6.4 Thermal Information.....	5	11 Device and Documentation Support	25
6.5 Electrical Characteristics: Current-Shunt Monitor.....	6	11.1 Related Links.....	25
6.6 Electrical Characteristics: Comparator.....	7	11.2 Receiving Notification of Documentation Updates.....	25
6.7 Electrical Characteristics: Reference.....	9	11.3 Support Resources.....	25
6.8 Electrical Characteristics: General.....	9	11.4 Trademarks.....	25
6.9 Typical Characteristics.....	10	11.5 Electrostatic Discharge Caution.....	25
7 Detailed Description	14	11.6 Glossary.....	25
7.1 Overview.....	14	12 Mechanical, Packaging, and Orderable Information	25
7.2 Functional Block Diagrams.....	14		

4 Revision History

NOTE: Page numbers for previous revisions may differ from page numbers in the current version.

Changes from Revision E (November 2015) to Revision F (June 2021)	Page
• Updated the numbering format for tables, figures, and cross-references throughout the document.....	1
• Changed maximum input voltage for accurate measurements from: $(V_{SHUNT} - 0.25) / \text{Gain}$ to: $(V_{OUT} - 0.25) / \text{Gain}$	15

Changes from Revision D (May 2009) to Revision E (November 2015)	Page
• Added <i>ESD Ratings</i> table, <i>Feature Description</i> section, <i>Device Functional Modes</i> , <i>Application and Implementation</i> section, <i>Power Supply Recommendations</i> section, <i>Layout</i> section, <i>Device and Documentation Support</i> section, and <i>Mechanical, Packaging, and Orderable Information</i> section	1
• Moved thermal values from <i>Electrical Characteristics: General</i> to <i>Thermal Information</i> table. Removed duplicate storage temperature parameter.....	9

Changes from Revision C (October 2007) to Revision D (May 2009)	Page
• Changed Figure 6-1	7

Device Comparison

Table 5-1. Device Gain

DEVICE	GAIN
INA203	20 V/V
INA204	50 V/V
INA205	100 V/V

Table 5-2. Related Products

FEATURES	PRODUCT
Variant of INA203–INA205 Comparator 2 polarity	INA206–INA208
Current-shunt monitor with single Comparator and V_{REF}	INA200–INA202
Current-shunt monitor only	INA193–INA198
Current-shunt monitor with split stages for filter options	INA270–INA271

5 Pin Configuration and Functions

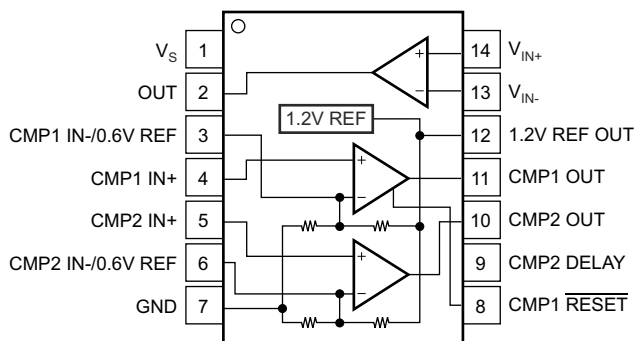

Figure 5-1. D and PW Packages 14-Pin SOIC and TSSOP Top View

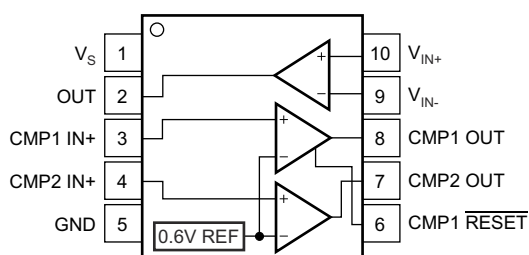

Figure 5-2. DGS Package 10-Pin VSSOP Top View

Table 5-1. Pin Functions

NAME	PIN		I/O	DESCRIPTION
	SOIC, TSSOP	VSSOP		
V _S	1	1	I	Power Supply
OUT	2	2	O	Output voltage
CMP1 IN-/0.6-V Ref	3	—	I	Comparator 1 negative input, can be used to override the internal 0.6-V reference
CMP1 IN+	4	3	I	Comparator 1 positive input
CMP2 IN+	5	—	I	Comparator 2 positive input
CMP2 IN-	—	4	I	Comparator 2 negative input
CMP2 IN-/0.6-V Ref	6	—	I	Comparator 2 negative input, can be used to override the internal 0.6-V reference
GND	7	5	I	Ground
CMP1 RESET	8	6	I	Comparator 1 output reset, active low
CMP2 DELAY	9	—	I	Connect an optional capacitor to adjust comparator 2 delay
CMP2 OUT	10	7	O	Comparator 2 output
CMP1 OUT	11	8	O	Comparator 1 output
1.2-V REF OUT	12	—	O	1.2-V reference output
V _{IN-}	13	9	I	Connect to shunt low side
V _{IN+}	14	10	I	Connect to shunt high side

6 Specifications

6.1 Absolute Maximum Ratings

See (1)

		MIN	MAX	UNIT
Supply Voltage, V_S			18	V
Current-Shunt Monitor Analog Inputs, V_{IN+} and V_{IN-}	Differential ($V_{IN+} - V_{IN-}$)	-18	18	V
	Common-Mode	-16	80	V
Comparator Analog Input and Reset Pins		GND - 0.3	$(V_S) + 0.3$	V
Analog Output, Out Pin		GND - 0.3	$(V_S) + 0.3$	V
Comparator Output, Out Pin		GND - 0.3	18	V
V_{REF} and CMP2 Delay Pin		GND - 0.3	10	V
Input Current Into Any Pin			5	mA
Operating Temperature		-55	150	°C
Junction Temperature		-65	150	°C
Storage temperature, T_{stg}		-65	150	°C

- (1) Stresses beyond those listed under *Absolute Maximum Ratings* may cause permanent damage to the device. These are stress ratings only, which do not imply functional operation of the device at these or any other conditions beyond those indicated under *Recommended Operating Conditions*. Exposure to absolute-maximum-rated conditions for extended periods may affect device reliability.

6.2 ESD Ratings

		VALUE	UNIT
$V_{(ESD)}$ Electrostatic discharge	Human body model (HBM), per ANSI/ESDA/JEDEC JS-001, all pins (1)	±4000	V
	Charged device model (CDM), per JEDEC specification JESD22-C101, all pins (2)	±500	

- (1) JEDEC document JEP155 states that 500-V HBM allows safe manufacturing with a standard ESD control process.
(2) JEDEC document JEP157 states that 250-V CDM allows safe manufacturing with a standard ESD control process.

6.3 Recommended Operating Conditions

over operating free-air temperature range (unless otherwise noted)

		MIN	NOM	MAX	UNIT
V_{CM}	Common-mode input voltage	-16	12	80	V
V_S	Operating supply voltage	2.7	12	18	V
T_A	Operating free-air temperature	-40	25	125	°C

6.4 Thermal Information

THERMAL METRIC (1)	INA20x			UNIT
	D (SOIC)	DGS (VSSOP)	PW (TSSOP)	
	14 PINS	10 PINS	14 PINS	
$R_{\theta JA}$ Junction-to-ambient thermal resistance	84.9	161.3	112.6	°C/W
$R_{\theta JC(top)}$ Junction-to-case (top) thermal resistance	44	36.8	37.2	°C/W
$R_{\theta JB}$ Junction-to-board thermal resistance	39.4	82.3	55.4	°C/W
Ψ_{JT} Junction-to-top characterization parameter	10.3	1.3	2.7	°C/W
Ψ_{JB} Junction-to-board characterization parameter	39.1	80.8	54.7	°C/W
$R_{\theta JC(bot)}$ Junction-to-case (bottom) thermal resistance	150	200	150	°C/W

- (1) For more information about traditional and new thermal metrics, see the *Semiconductor and IC Package Thermal Metrics* application report, [SPRA953](#).

6.5 Electrical Characteristics: Current-Shunt Monitor

At $T_A = 25^\circ\text{C}$, $V_S = 12\text{ V}$, $V_{CM} = 12\text{ V}$, $V_{SENSE} = 100\text{ mV}$, $R_L = 10\text{ k}\Omega$ to GND, $R_{pullup} = 5.1\text{ k}\Omega$ each connected from CMP1 OUT and CMP2 OUT to V_S , and CMP1 IN+ = 1 V and CMP2 IN- = GND, unless otherwise noted.

PARAMETER		TEST CONDITIONS		MIN	TYP	MAX	UNIT
INPUT							
V_{SENSE}	Full-Scale Sense Input Voltage	$V_{SENSE} = V_{IN+} - V_{IN-}$			0.15	$(V_S - 0.25)/\text{Gain}$	V
V_{CM}	Common-Mode Input Range	$T_A = -40^\circ\text{C}$ to 125°C		-16		80	V
CMRR	Common-Mode Rejection Ratio	$V_{CM} = -16\text{ V}$ to 80 V		80	100		dB
	CMRR over Temperature	$V_{CM} = 12\text{ V}$ to 80 V	$T_A = -40^\circ\text{C}$ to 125°C	100	123		dB
V_{OS}	Offset Voltage, RTI ⁽¹⁾				± 0.5	± 2.5	mV
		25°C to 125°C				± 3	mV
		-40°C to 25°C				± 3.5	mV
dV_{OS}/dT	Offset Voltage, RTI ⁽¹⁾ vs. Temperature	T_{MIN} to T_{MAX}	$T_A = -40^\circ\text{C}$ to 125°C		5		$\mu\text{V}/^\circ\text{C}$
PSR	Offset Voltage, RTI ⁽¹⁾ vs. Power Supply	$V_{OUT} = 2\text{ V}$, $V_{CM} = 18\text{ V}$, 2.7 V	$T_A = -40^\circ\text{C}$ to 125°C		2.5	100	$\mu\text{V}/\text{V}$
I_B	Input Bias Current, V_{IN-} Pin	$T_A = -40^\circ\text{C}$ to 125°C			± 9	± 16	μA
OUTPUT ($V_{SENSE} \geq 20\text{ mV}$)							
G	Gain	INA203			20		V/V
		INA204			50		V/V
		INA205			100		V/V
	Gain Error	$V_{SENSE} = 20\text{ mV}$ to 100 mV			$\pm 0.2\%$	$\pm 1\%$	
	Gain Error over Temperature	$V_{SENSE} = 20\text{ mV}$ to 100 mV	$T_A = -40^\circ\text{C}$ to 125°C			$\pm 2\%$	
	Total Output Error ⁽²⁾	$V_{SENSE} = 120\text{ mV}$, $V_S = 16\text{ V}$			$\pm 0.75\%$	$\pm 2.2\%$	
	Total Output Error ⁽²⁾ over Temperature	$V_{SENSE} = 120\text{ mV}$, $V_S = 16\text{ V}$	$T_A = -40^\circ\text{C}$ to 125°C			$\pm 3.5\%$	
	Nonlinearity Error ⁽³⁾	$V_{SENSE} = 20\text{ mV}$ to 100 mV			$\pm 0.002\%$		
R_O	Output Impedance, Pin 2				1.5		Ω
	Maximum Capacitive Load	No Sustained Oscillation			10		nF
OUTPUT ($V_{SENSE} < 20\text{ mV}$) ⁽⁴⁾							
	INA203, INA204, INA205 output	$-16\text{ V} \leq V_{CM} < 0\text{ V}$			300		mV
	INA203 output	$0\text{ V} \leq V_{CM} \leq V_S$, $V_S = 5\text{ V}$				0.4	V
	INA204 output	$0\text{ V} \leq V_{CM} \leq V_S$, $V_S = 5\text{ V}$				1	V
	INA205 output	$0\text{ V} \leq V_{CM} \leq V_S$, $V_S = 5\text{ V}$				2	V
	INA203, INA204, INA205 output	$V_S < V_{CM} \leq 80\text{ V}$			300		mV
VOLTAGE OUTPUT ⁽⁵⁾							
	Output Swing to the Positive Rail	$V_{IN-} = 11\text{ V}$, $V_{IN+} = 12\text{ V}$	$T_A = -40^\circ\text{C}$ to 125°C		$(V_S) - 0.15$	$(V_S) - 0.25$	V
	Output Swing to GND ⁽⁶⁾	$V_{IN-} = 0\text{ V}$, $V_{IN+} = -0.5\text{ V}$	$T_A = -40^\circ\text{C}$ to 125°C		$(V_{GND}) + 0.004$	$(V_{GND}) + 0.05$	V

At $T_A = 25^\circ\text{C}$, $V_S = 12\text{ V}$, $V_{CM} = 12\text{ V}$, $V_{SENSE} = 100\text{ mV}$, $R_L = 10\text{ k}\Omega$ to GND, $R_{pullup} = 5.1\text{ k}\Omega$ each connected from CMP1 OUT and CMP2 OUT to V_S , and CMP1 IN+ = 1 V and CMP2 IN- = GND, unless otherwise noted.

PARAMETER		TEST CONDITIONS	MIN	TYP	MAX	UNIT
FREQUENCY RESPONSE						
BW	Bandwidth	INA203; $C_{LOAD} = 5\text{ pF}$		500		kHz
		INA204; $C_{LOAD} = 5\text{ pF}$		300		kHz
		INA205; $C_{LOAD} = 5\text{ pF}$		200		kHz
	Phase Margin	$C_{LOAD} < 10\text{ nF}$		40		
SR	Slew Rate			1		V/ μs
	Settling Time (1%)	$V_{SENSE} = 10\text{ mV}_{PP}$ to 100 mV_{PP} , $C_{LOAD} = 5\text{ pF}$		2		μs
NOISE, RTI						
	Output Voltage Noise Density			40		nV/ $\sqrt{\text{Hz}}$

- (1) Offset is extrapolated from measurements of the output at 20 mV and 100 mV V_{SENSE} .
- (2) Total output error includes effects of gain error and V_{OS} .
- (3) Linearity is best fit to a straight line.
- (4) For details on this region of operation, see the [Accuracy Variations as a Result Of \$V_{SENSE}\$ and Common-Mode Voltage](#) section in the [Application and Implementation](#).
- (5) See Typical Characteristic curve [Positive Output Voltage Swing vs. Output Current \(Positive Output Voltage Swing vs. Output Current\)](#).
- (6) Specified by design; not production tested.

6.6 Electrical Characteristics: Comparator

At $T_A = 25^\circ\text{C}$, $V_S = 12\text{ V}$, $V_{CM} = 12\text{ V}$, $V_{SENSE} = 100\text{ mV}$, $R_L = 10\text{ k}\Omega$ to GND, and $R_{pullup} = 5.1\text{ k}\Omega$ each connected from CMP1 OUT and CMP2 OUT to V_S , unless otherwise noted.

PARAMETER		TEST CONDITIONS	MIN	TYP	MAX	UNIT
OFFSET VOLTAGE						
	Offset Voltage	Comparator Common-Mode Voltage = Threshold Voltage		2		mV
	Offset Voltage Drift, Comparator 1	$T_A = -40^\circ\text{C}$ to 125°C		± 2		$\mu\text{V}/^\circ\text{C}$
	Offset Voltage Drift, Comparator 2	$T_A = -40^\circ\text{C}$ to 125°C		5.4		$\mu\text{V}/^\circ\text{C}$
	Threshold	$T_A = 25^\circ\text{C}$	590	608	620	mV
	Threshold over Temperature	$T_A = -40^\circ\text{C}$ to 125°C	586		625	mV
	Hysteresis ⁽¹⁾ , CMP1	$T_A = -40^\circ\text{C}$ to 85°C		-8		mV
	Hysteresis ⁽¹⁾ , CMP2	$T_A = -40^\circ\text{C}$ to 85°C		8		mV
INPUT BIAS CURRENT ⁽²⁾						
	CMP1 IN+, CMP2 IN+			0.005	10	nA
	CMP1 IN+, CMP2 IN+ vs. Temperature	$T_A = -40^\circ\text{C}$ to 125°C			15	nA
INPUT IMPEDANCE						
	Pins 3 and 6 (14-pin packages only)			10		k Ω
INPUT RANGE						
	CMP1 IN+ and CMP2 IN+			0 V to $V_S - 1.5\text{ V}$		V
	Pins 3 and 6 (14-pin packages only) ⁽³⁾			0 V to $V_S - 1.5\text{ V}$		V
OUTPUT						
	Large-Signal Differential Voltage Gain	CMP V_{OUT} 1 V to 4 V, $R_L \geq 15\text{ k}\Omega$ Connected to 5 V		200		V/mV

At $T_A = 25^\circ\text{C}$, $V_S = 12\text{ V}$, $V_{CM} = 12\text{ V}$, $V_{SENSE} = 100\text{ mV}$, $R_L = 10\text{ k}\Omega$ to GND, and $R_{pullup} = 5.1\text{ k}\Omega$ each connected from CMP1 OUT and CMP2 OUT to V_S , unless otherwise noted.

PARAMETER	TEST CONDITIONS	MIN	TYP	MAX	UNIT
High-Level Output Current	$V_{ID} = 0.4\text{ V}$, $V_{OH} = V_S$		0.0001	1	μA
Low-Level Output Voltage	$V_{ID} = -0.6\text{ V}$, $I_{OL} = 2.35\text{ mA}$		220	300	mV
RESPONSE TIME ⁽⁴⁾					
Comparator 1	R_L to 5 V, $C_L = 15\text{ pF}$, 100-mV Input Step with 5-mV Overdrive		1.3		μs
Comparator 2	R_L to 5 V, $C_L = 15\text{ pF}$, 100-mV Input Step with 5-mV Overdrive, C_{DELAY} Pin Open		1.3		μs
RESET					
RESET Threshold ⁽⁵⁾			1.1		V
Logic Input Impedance			2		M Ω
Minimum RESET Pulse Width			1.5		μs
RESET Propagation Delay			3		μs
Comparator 2 Delay Equation ⁽⁶⁾			$C_{DELAY} = t_D/5$		μF
t_D Comparator 2 Delay	$C_{DELAY} = 0.1\text{ }\mu\text{F}$		0.5		s

- (1) Hysteresis refers to the threshold (the threshold specification applies to a rising edge of a noninverting input) of a falling edge on the noninverting input of the comparator; refer to [Figure 6-1](#).
- (2) Specified by design; not production tested.
- (3) See the [Comparator Maximum Input Voltage Range](#) section in the [Application and Implementation](#).
- (4) The comparator response time specified is the interval between the input step function and the instant when the output crosses 1.4 V.
- (5) The CMP1 RESET input has an internal 2-M Ω (typical) pulldown. Leaving the CMP1 RESET open results in a LOW state, with transparent comparator operation.
- (6) The Comparator 2 delay applies to both rising and falling edges of the comparator output.

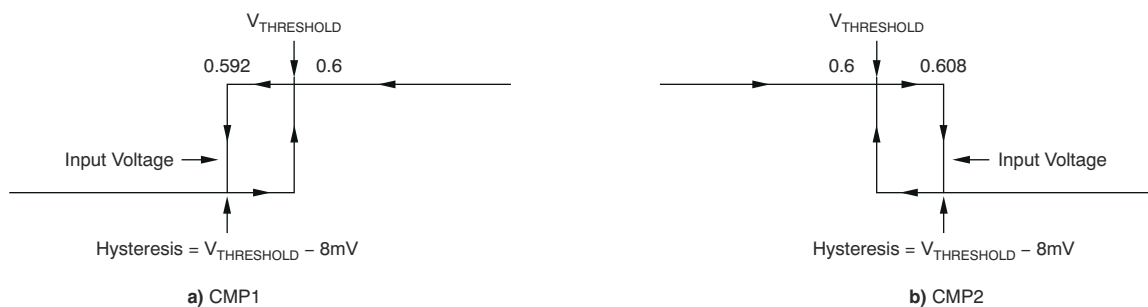

Figure 6-1. Comparator Hysteresis

6.7 Electrical Characteristics: Reference

At $T_A = 25^\circ\text{C}$, $V_S = 12\text{ V}$, $V_{CM} = 12\text{ V}$, $V_{SENSE} = 100\text{ mV}$, $R_L = 10\text{ k}\Omega$ to GND, and $R_{pullup} = 5.1\text{ k}\Omega$ each connected from CMP1 OUT and CMP2 OUT to V_S , unless otherwise noted.

PARAMETER	TEST CONDITIONS	MIN	TYP	MAX	UNIT
REFERENCE VOLTAGE					
1.2- V_{REFOUT} Output Voltage		1.188	1.2	1.212	V
dV_{OUT}/dT Reference Drift	$T_A = -40^\circ\text{C}$ to 85°C		40	100	ppm/ $^\circ\text{C}$
0.6- V_{REF} Output Voltage	Pins 3 and 6 of 14-pin packages only		0.6		V
dV_{OUT}/dT Reference Drift	$T_A = -40^\circ\text{C}$ to 85°C		40	100	ppm/ $^\circ\text{C}$
LOAD REGULATION dV_{OUT}/dI_{LOAD}					
Sourcing	$0\text{mA} < I_{SOURCE} < 0.5\text{mA}$		0.4	2	mV/mA
Sinking	$0\text{mA} < I_{SINK} < 0.5\text{mA}$		0.4		mV/mA
I_{LOAD} Load Current			1		mA
dV_{OUT}/dV_S Line Regulation	$2.7\text{ V} < V_S < 18\text{ V}$		30		$\mu\text{V}/\text{V}$
CAPACITIVE LOAD					
Reference Output Maximum Capacitive Load	No Sustained Oscillations		10		nF
OUTPUT IMPEDANCE					
Output Impedance	Pins 3 and 6 of 14-Pin Packages Only		10		k Ω

6.8 Electrical Characteristics: General

All specifications at $T_A = 25^\circ\text{C}$, $V_S = 12\text{ V}$, $V_{CM} = 12\text{ V}$, $V_{SENSE} = 100\text{ mV}$, $R_L = 10\text{ k}\Omega$ to GND, $R_{pullup} = 5.1\text{ k}\Omega$ each connected from CMP1 OUT and CMP2 OUT to V_S , and CMP1 IN+ = 1 V and CMP2 IN- = GND, unless otherwise noted.

PARAMETER	TEST CONDITIONS	MIN	TYP	MAX	UNIT
POWER SUPPLY					
V_S Operating power supply	$T_A = -40^\circ\text{C}$ to 125°C	2.7		18	V
I_Q Quiescent current	$V_{OUT} = 2\text{ V}$		1.8	2.2	mA
Quiescent current over temperature	$V_{SENSE} = 0\text{ mV}$			2.8	mA
Comparator power-on reset threshold ⁽¹⁾			1.5		V
TEMPERATURE					
Specified temperature		-40		125	$^\circ\text{C}$
Operating temperature		-55		150	$^\circ\text{C}$

- (1) The INA203, INA204, and INA205 are designed to power-up with the comparator in a defined reset state as long as CMP1 $\overline{\text{RESET}}$ is open or grounded. The comparator will be in reset as long as the power supply is below the voltage shown here. The comparator assumes a state based on the comparator input above this supply voltage. If CMP1 $\overline{\text{RESET}}$ is high at power-up, the comparator output comes up high and requires a reset to assume a low state, if appropriate.

6.9 Typical Characteristics

All specifications at $T_A = 25^\circ\text{C}$, $V_S = 12\text{ V}$, $V_{CM} = 12\text{ V}$, and $V_{SENSE} = 100\text{ mV}$, unless otherwise noted.

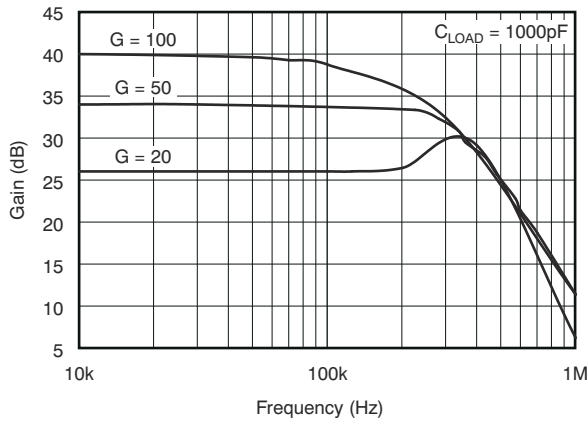

Figure 6-2. Gain vs. Frequency

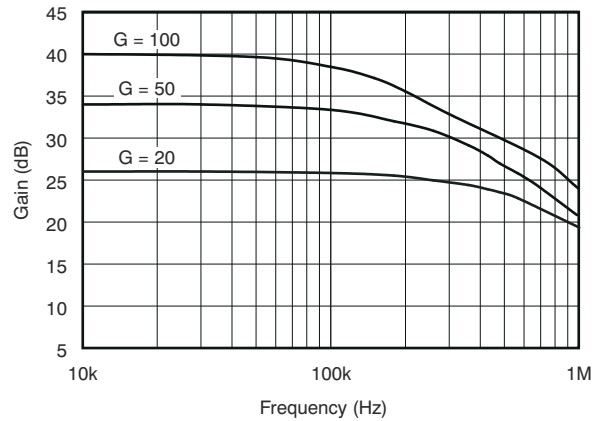

Figure 6-3. Gain vs. Frequency

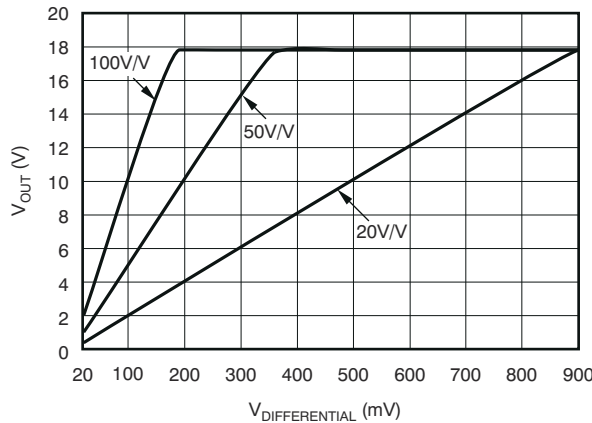

Figure 6-4. Gain Plot

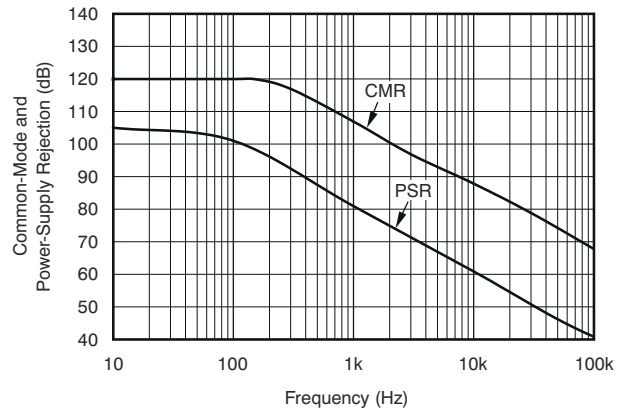

Figure 6-5. Common-Mode and Power-Supply Rejection vs. Frequency

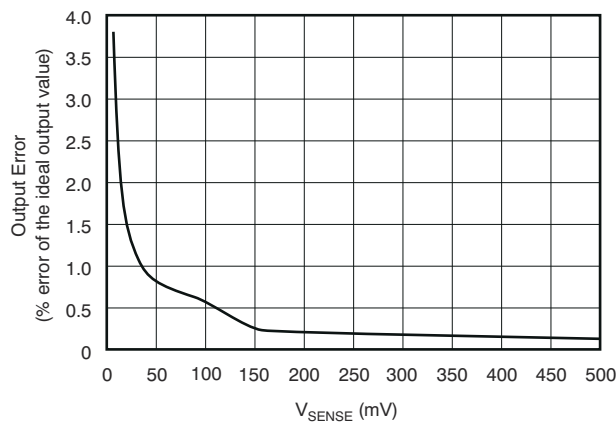

Figure 6-6. Total Output Error vs. V_{SENSE}

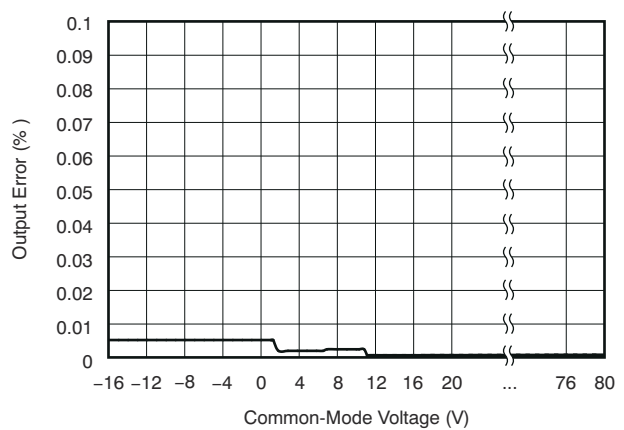

Figure 6-7. Total Output Error vs. Common-Mode Voltage

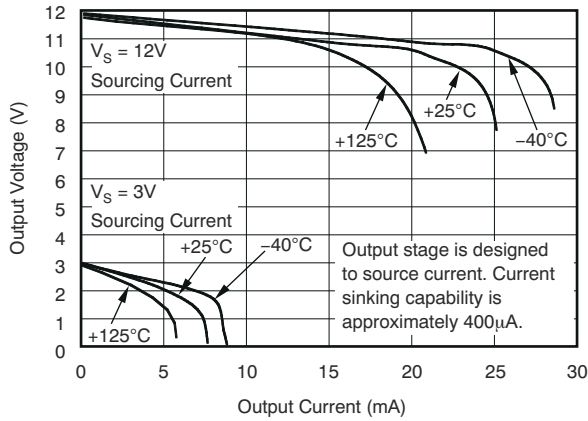

Figure 6-8. Positive Output Voltage Swing vs. Output Current

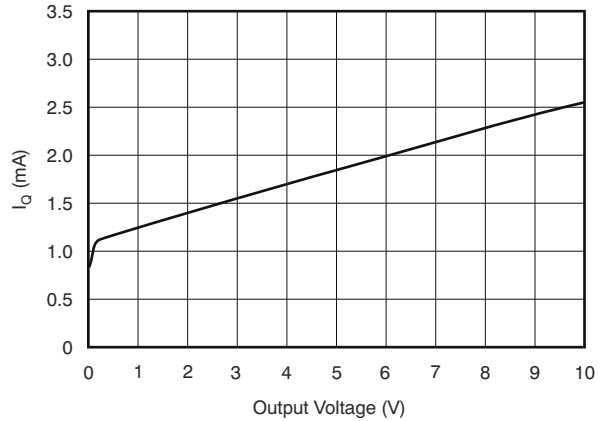

Figure 6-9. Quiescent Current vs. Output Voltage

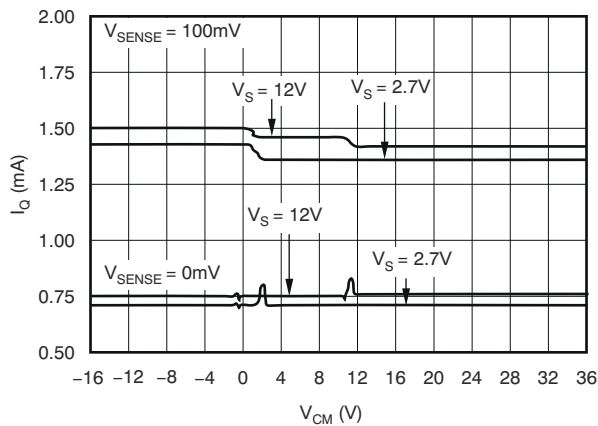

Figure 6-10. Quiescent Current vs. Common-Mode Voltage

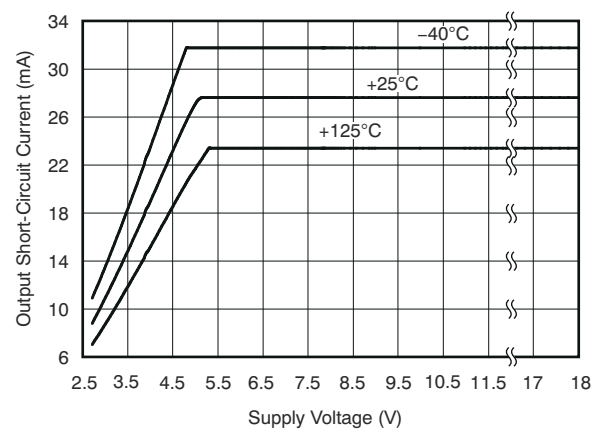

Figure 6-11. Output Short-Circuit Current vs. Supply Voltage

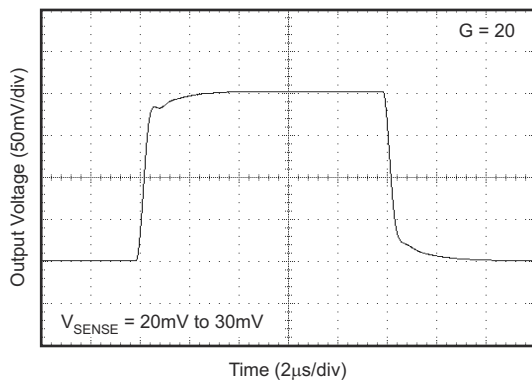

Figure 6-12. Step Response

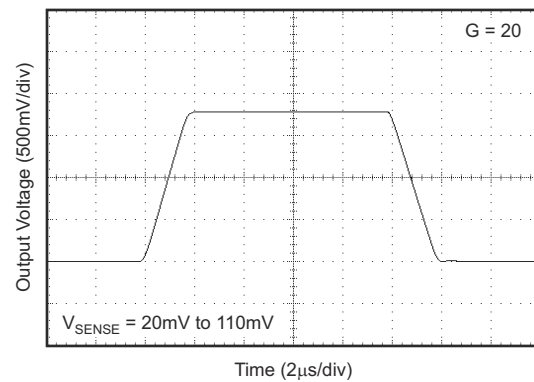

Figure 6-13. Step Response

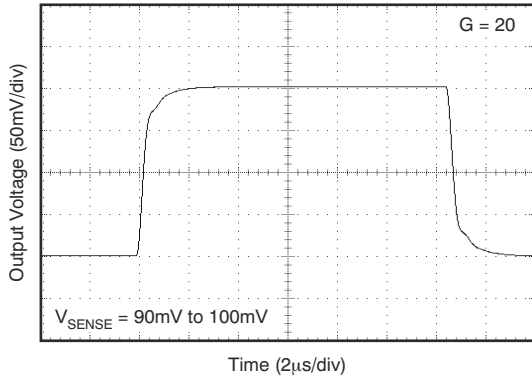

Figure 6-14. Step Response

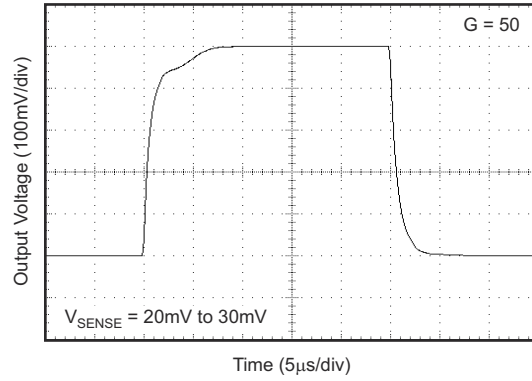

Figure 6-15. Step Response

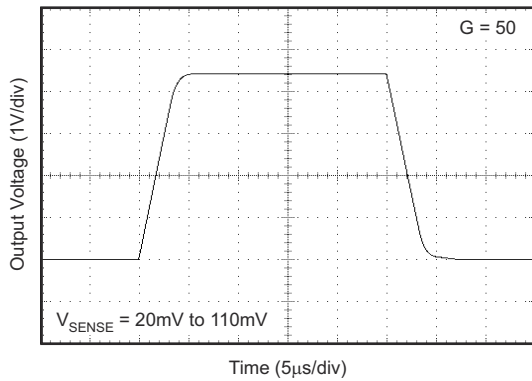

Figure 6-16. Step Response

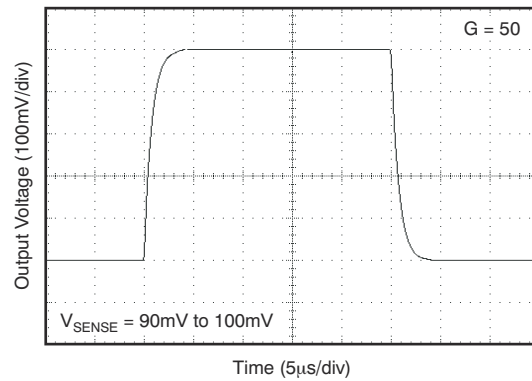

Figure 6-17. Step Response

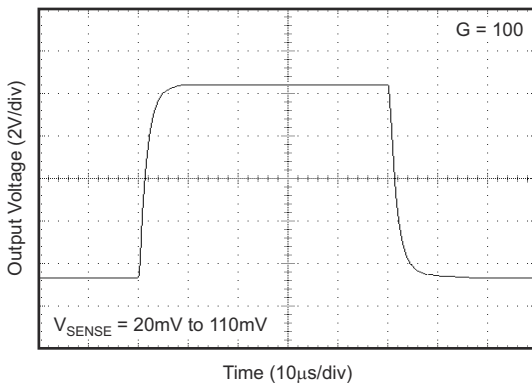

Figure 6-18. Step Response

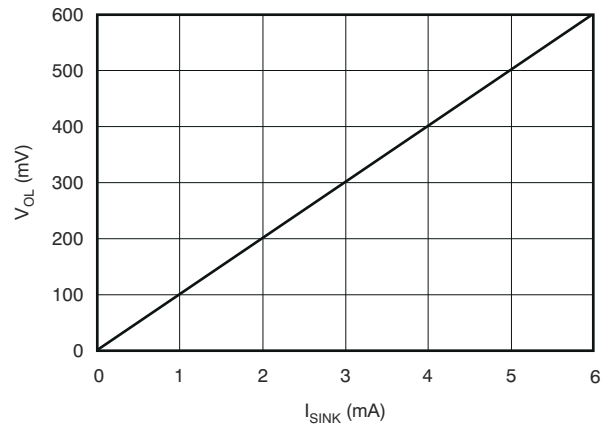

Figure 6-19. Comparator V_{OL} vs. I_{SINK}

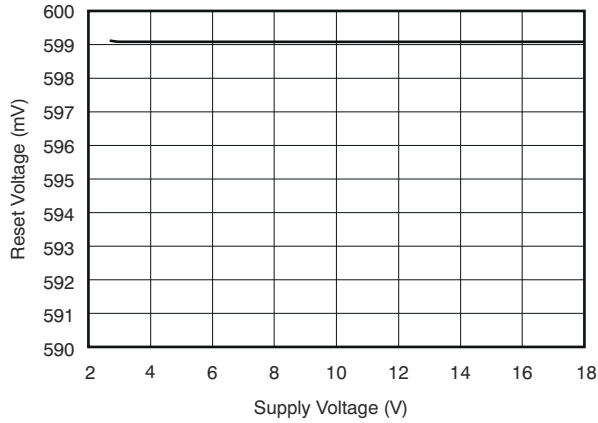

Figure 6-20. Comparator Trip Point vs. Supply Voltage

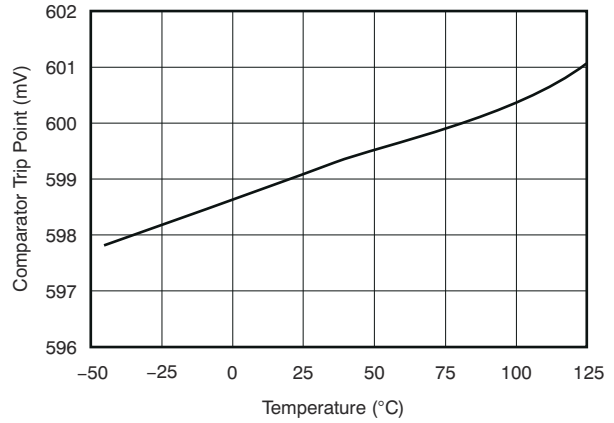

Figure 6-21. Comparator Trip Point vs. Temperature

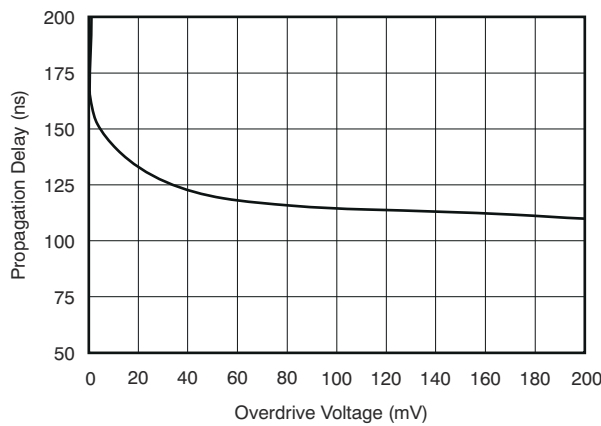

Figure 6-22. Comparator 1 Propagation Delay vs. Overdrive Voltage

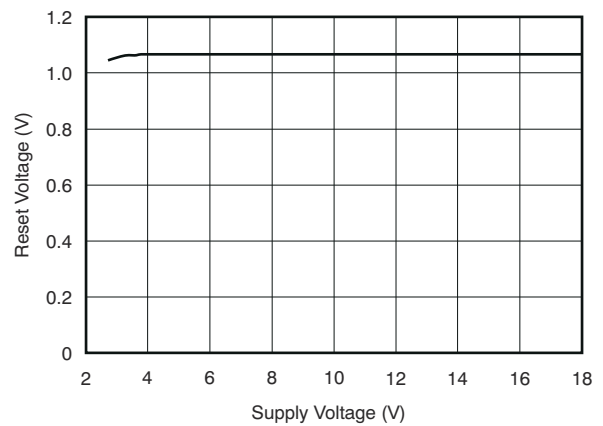

Figure 6-23. Comparator Reset Voltage vs. supply Voltage

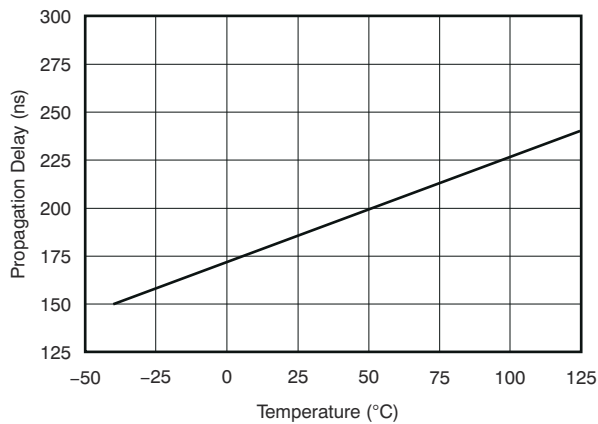

Figure 6-24. Comparator Propagation Delay vs. Temperature

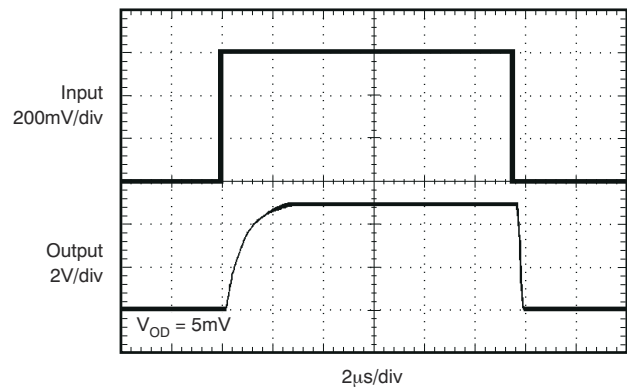

Figure 6-25. Comparator Propagation Delay

7 Detailed Description

7.1 Overview

The INA203, INA204, and INA205 are a family of unidirectional current-shunt monitors with voltage output, dual comparators, and voltage reference. The INA203, INA204, and INA205 can sense drops across shunts at common-mode voltages from -16 V to 80 V . The INA203, INA204, and INA205 are available with three output voltage scales: 20 V/V , 50 V/V , and 100 V/V , with up to 500-kHz bandwidth. The INA203, INA204, and INA205 also incorporate two open-drain comparators with internal 0.6-V references. On 14-pin versions, the comparator references can be overridden by external inputs. Comparator 1 includes a latching capability, and Comparator 2 has a user-programmable delay. 14-pin versions also provide a 1.2-V reference output. The INA203, INA204, and INA205 operate from a single 2.7-V to 18-V supply. They are specified over the extended operating temperature range of -40°C to 125°C .

7.2 Functional Block Diagrams

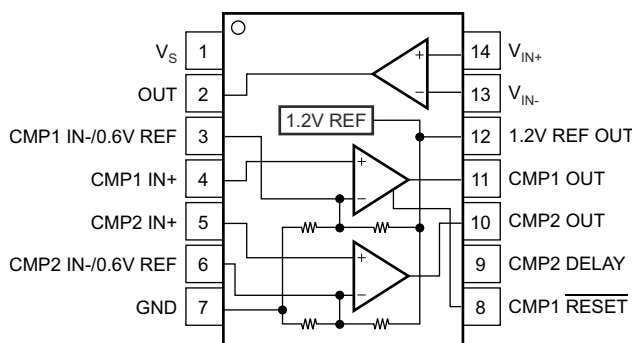

Figure 7-1. SO-14, TSSOP-14 Functional Block Diagram

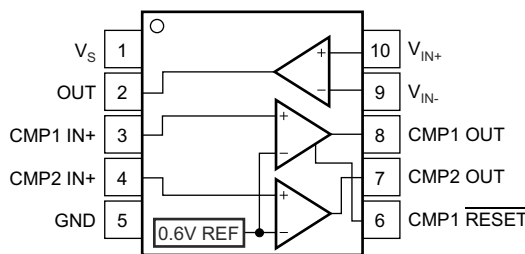

Figure 7-2. VSSOP-10 Functional Block Diagram

7.3 Feature Description

7.3.1 Basic Connections

Figure 7-3 shows the basic connections of the INA203, INA204, and INA205. The input pins, V_{IN+} and V_{IN-} , should be connected as closely as possible to the shunt resistor to minimize any resistance in series with the shunt resistance.

Power-supply bypass capacitors are required for stability. Applications with noisy or high-impedance power supplies may require additional decoupling capacitors to reject power-supply noise. Connect bypass capacitors close to the device pins.

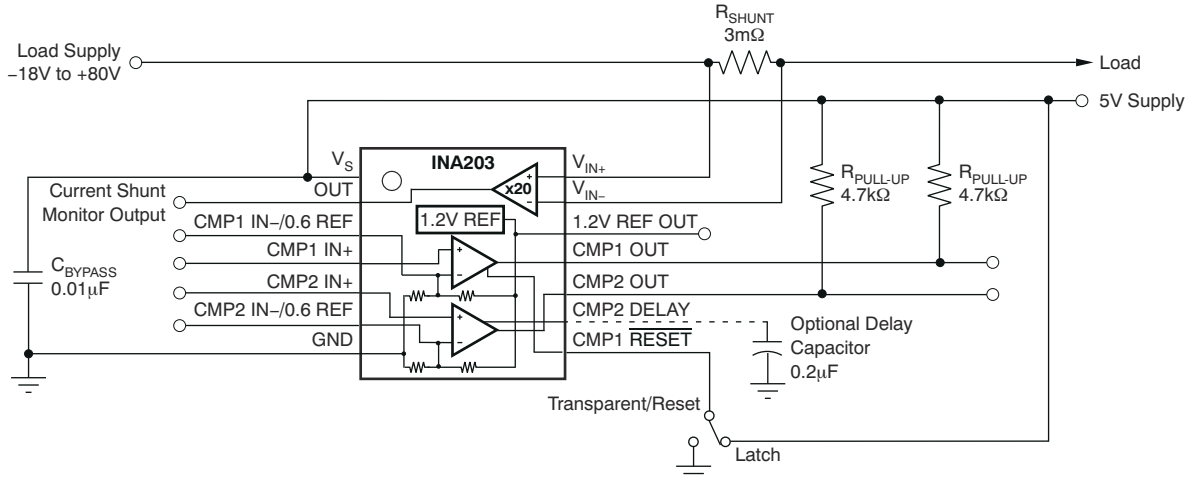

Figure 7-3. INA20x Basic Connection

7.3.2 Selecting R_{SHUNT}

The value chosen for the shunt resistor, R_{SHUNT} , depends on the application and is a compromise between small-signal accuracy and maximum permissible voltage loss in the measurement line. High values of R_{SHUNT} provide better accuracy at lower currents by minimizing the effects of offset, while low values of R_{SHUNT} minimize voltage loss in the supply line. For most applications, best performance is attained with an R_{SHUNT} value that provides a full-scale shunt voltage range of 50 mV to 100 mV. Maximum input voltage for accurate measurements is $(V_{OUT} - 0.25) / \text{Gain}$.

7.3.3 Comparator

The INA203, INA204, and INA205 devices incorporate two open-drain comparators. These comparators typically have 2 mV of offset and a 1.3- μs (typical) response time. The output of Comparator 1 latches and is reset through the $\text{CMP1 } \overline{\text{RESET}}$ pin, as shown in Figure 7-5. This configuration applies to both the 10- and 14-pin versions. Figure 7-4 illustrates the comparator delay.

The 14-pin versions of the INA203, INA204, and INA205 devices include additional features for comparator functions. The comparator reference voltage of both Comparator 1 and Comparator 2 can be overridden by external inputs for increased design flexibility. Comparator 2 has a programmable delay.

7.3.4 Comparator Delay (14-Pin Version Only)

The Comparator 2 programmable delay is controlled by a capacitor connected to the CMP2 Delay Pin ; see Figure 7-3. The capacitor value (in μF) is selected by using Equation 1:

$$C_{\text{DELAY}} \text{ (in } \mu\text{F)} = \frac{t_D}{5} \quad (1)$$

A simplified version of the delay circuit for Comparator 2 is shown in Figure 7-4. The delay comparator consists of two comparator stages with the delay between them. I1 and I2 cannot be turned on simultaneously; I1 corresponds to a U1 low output and I2 corresponds to a U1 high output. Using an initial assumption that the U1 output is low, I1 is on, then U2 +IN is zero. If U1 goes high, I2 supplies 120 nA to C_{DELAY} . The voltage at U2 +IN begins to ramp toward a 0.6-V threshold. When the voltage crosses this threshold, the U2 output goes high while the voltage at U2 +IN continues to ramp up to a maximum of 1.2 V when given sufficient time (twice the value of the delay specified for C_{DELAY}). This entire sequence is reversed when the comparator outputs go low, so that returning to low exhibits the same delay.

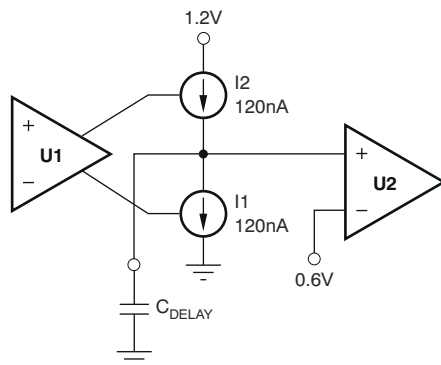

Figure 7-4. Simplified Model of the Comparator 2 Delay Circuit

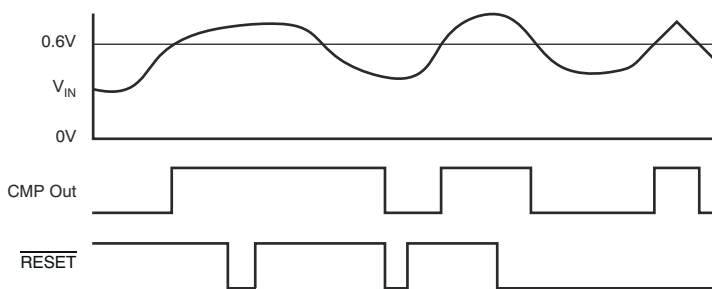

Figure 7-5. Comparator Latching Capability

Take care to note what will happen if events occur more rapidly than the delay timeout; for example, when the U1 output goes high (turning on I2), but returns low (turning I1 back on) prior to reaching the 0.6-V transition for U2. The voltage at U2 +IN ramps back down at a rate determined by the value of C_{DELAY}, and only returns to zero if given sufficient time.

In essence, when analyzing Comparator 2 for behavior with events more rapid than its delay setting, use the model shown in [Figure 7-4](#).

7.3.5 Comparator Maximum Input Voltage Range

The maximum voltage at the comparator input for normal operation is up to (V_s) – 1.5 V. There are special considerations when overdriving the reference inputs (pins 3 and 6). Driving either or both inputs high enough to drive 1 mA back into the reference introduces errors into the reference. [Figure 7-6](#) shows the basic input structure. A general guideline is to limit the voltage on both inputs to a total of 20 V. The exact limit depends on the available voltage and whether either or both inputs are subject to the large voltage. When making this determination, consider the 20 kΩ from each input back to the comparator. [Figure 7-7](#) shows the maximum input voltage that avoids creating a reference error when driving both inputs (an equivalent resistance back into the reference of 10 kΩ).

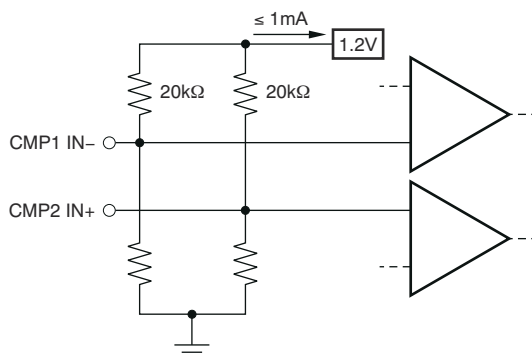

Figure 7-6. Limit Current Into Reference ≤ 1 mA

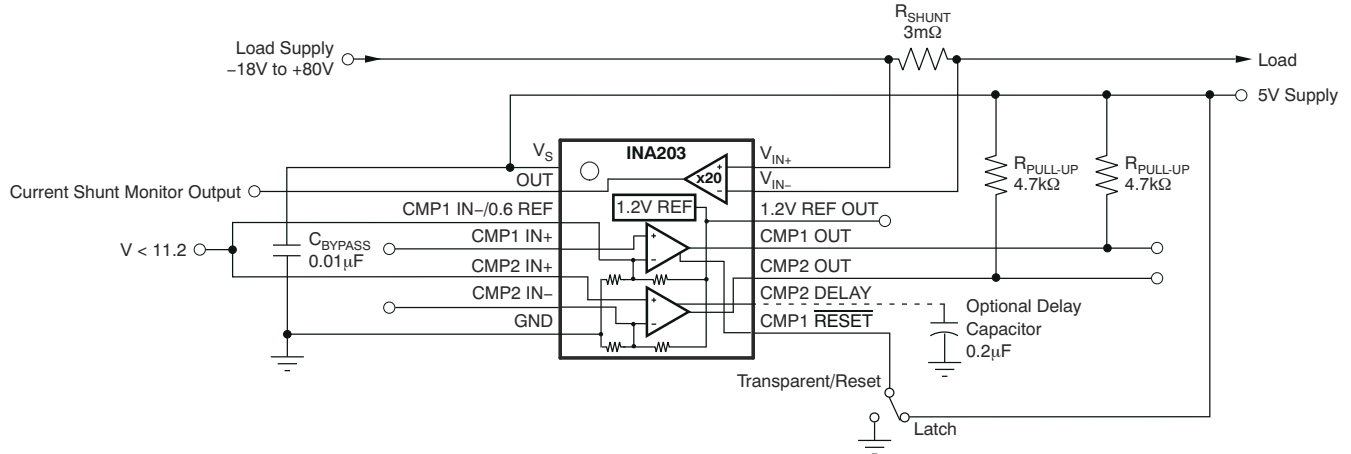
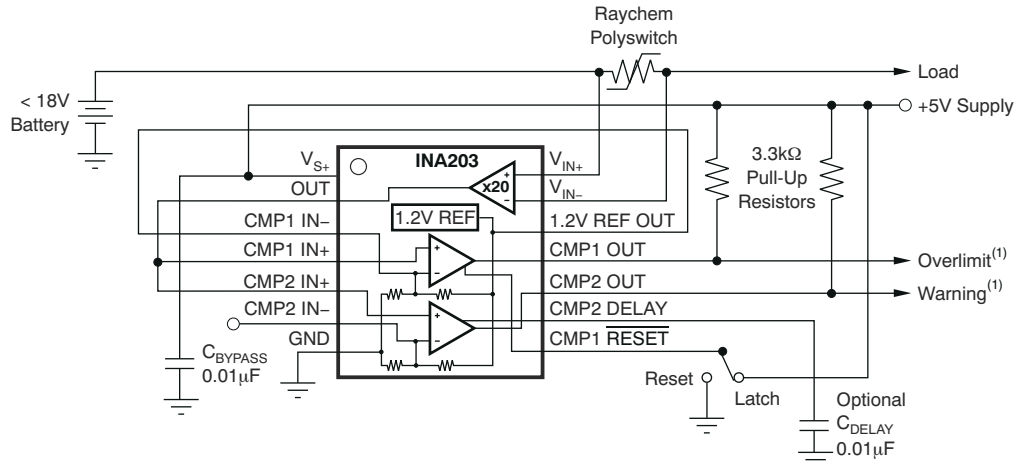

Figure 7-7. Overdriving Comparator Inputs Without Generating a Reference Error



NOTE: (1) Warning at half current (with optional delay). Overlimit latches when Polyswitch opens.

Figure 7-8. Polyswitch Warning and Fault Detection Circuit

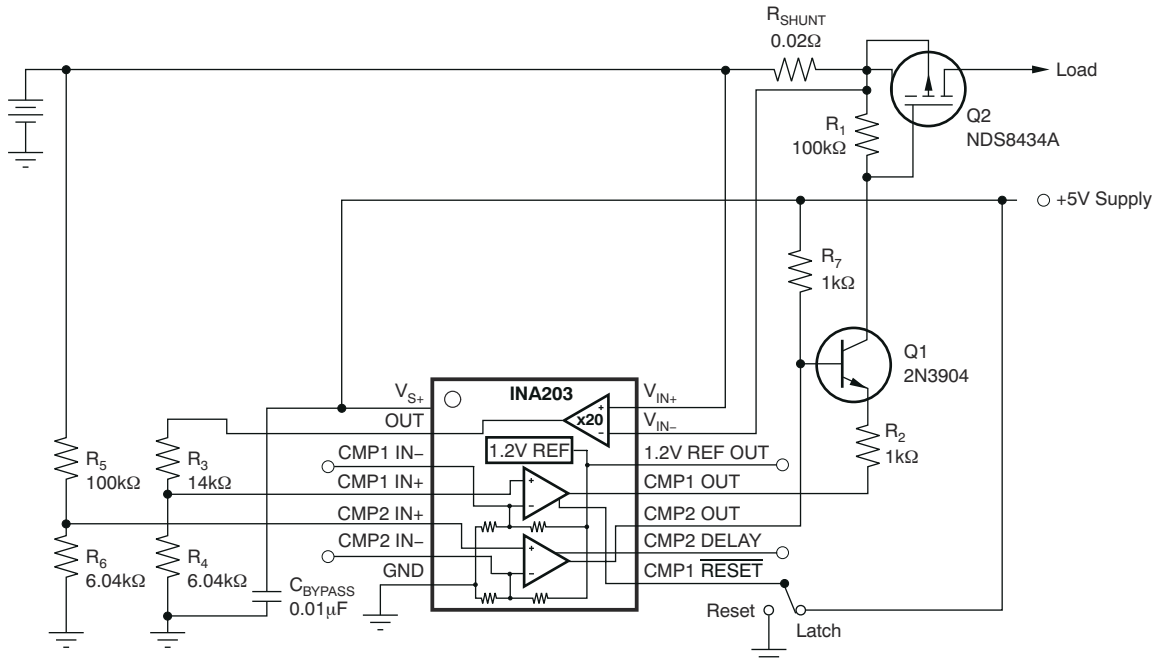

Figure 7-9. Lead-Acid Battery Protection Circuit

7.4 Device Functional Modes

7.4.1 Input Filtering

An obvious and straightforward location for filtering is at the output of the INA203, INA204, and INA205 series; however, this location negates the advantage of the low output impedance of the internal buffer. The only other option for filtering is at the input pins of the INA203, INA204, and INA205, which is complicated by the internal 5 kΩ + 30% input impedance; this configuration is illustrated in [Figure 7-10](#). Using the lowest possible resistor values minimizes both the initial shift in gain and effects of tolerance. Use [Equation 2](#) to calculate the effect on initial gain.

$$\text{Gain Error \%} = 100 - \left(100 \times \frac{5\text{k}\Omega}{5\text{k}\Omega + R_{\text{FILT}}} \right) \quad (2)$$

Total effect on gain error can be calculated by replacing the 5-kΩ term with 5 kΩ – 30%, (or 3.5 kΩ) or 5 kΩ + 30% (or 6.5 kΩ). The tolerance extremes of R_{FILT} can also be inserted into the equation. If a pair of 100 Ω 1% resistors are used on the inputs, the initial gain error will be 1.96%. Worst-case tolerance conditions will always occur at the lower excursion of the internal 5-kΩ resistor (3.5 kΩ), and the higher excursion of R_{FILT} – 3% in this case.

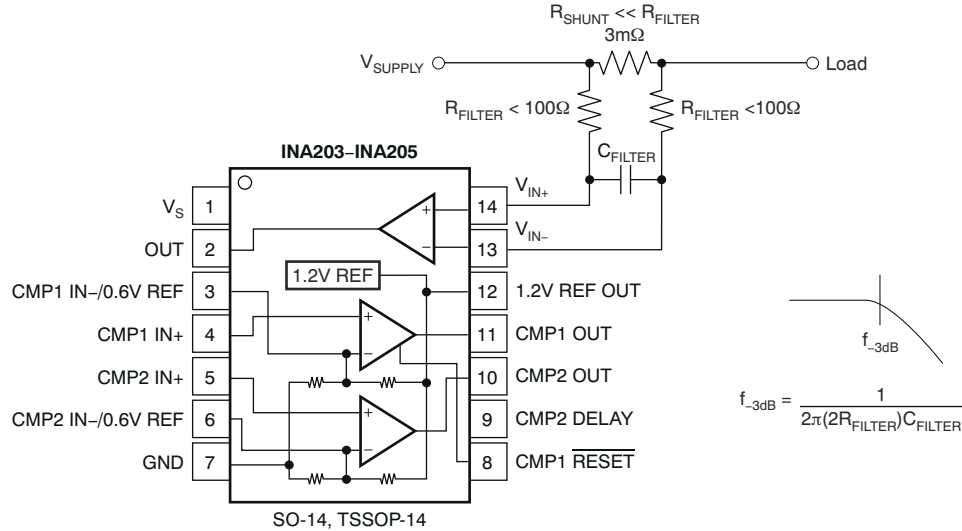

Figure 7-10. Input Filter (Gain Error: 1.5% to -2.2%)

The specified accuracy of the INA203, INA204, and INA205 must then be combined in addition to these tolerances. While this discussion treated accuracy worst-case conditions by combining the extremes of the resistor values, it is appropriate to use geometric mean or root sum square calculations to total the effects of accuracy variations.

7.4.2 Accuracy Variations as a Result Of V_{SENSE} and Common-Mode Voltage

The accuracy of the INA203, INA204, and INA205 current shunt monitors is a function of two main variables: V_{SENSE} ($V_{IN+} - V_{IN-}$) and common-mode voltage, V_{CM} , relative to the supply voltage, V_S . V_{CM} is expressed as $(V_{IN+} + V_{IN-}) / 2$; however, in practice, V_{CM} is seen as the voltage at V_{IN+} because the voltage drop across V_{SENSE} is usually small.

This section addresses the accuracy of these specific operating regions:

- Normal Case 1: $V_{SENSE} \geq 20$ mV, $V_{CM} \geq V_S$
- Normal Case 2: $V_{SENSE} \geq 20$ mV, $V_{CM} < V_S$
- Low V_{SENSE} Case 1: $V_{SENSE} < 20$ mV, -16 V $\leq V_{CM} < 0$
- Low V_{SENSE} Case 2: $V_{SENSE} < 20$ mV, 0 V $\leq V_{CM} \leq V_S$
- Low V_{SENSE} Case 3: $V_{SENSE} < 20$ mV, $V_S < V_{CM} \leq 80$ V

7.4.2.1 Normal Case 1: $V_{SENSE} \geq 20$ mV, $V_{CM} \geq V_S$

This region of operation provides the highest accuracy. Here, the input offset voltage is characterized and measured using a two-step method. First, the gain is determined by Equation 3.

$$G = \frac{V_{OUT1} - V_{OUT2}}{100\text{mV} - 20\text{mV}} \quad (3)$$

where

- V_{OUT1} = Output Voltage with $V_{SENSE} = 100$ mV.
- V_{OUT2} = Output Voltage with $V_{SENSE} = 20$ mV.

Then the offset voltage is measured at $V_{SENSE} = 100$ mV and referred to the input (RTI) of the current shunt monitor, as shown in Equation 4.

$$V_{OS,RTI} \text{ (Referred-To-Input)} = \left[\frac{V_{OUT1}}{G} \right] - 100\text{mV} \quad (4)$$

In the *Typical Characteristics*, [Total Output Error vs. Common-Mode Voltage](#) shows the highest accuracy for this region of operation. In this plot, $V_S = 12\text{ V}$; for $V_{CM} \geq 12\text{ V}$, the output error is at its minimum. This case is also used to create the $V_{SENSE} \geq 20\text{-mV}$ output specifications in the *Electrical Characteristics: Current-Shunt Monitor* table.

7.4.2.2 Normal Case 2: $V_{SENSE} \geq 20\text{ mV}$, $V_{CM} < V_S$

This region of operation has slightly less accuracy than Normal Case 1 as a result of the common-mode operating area in which the part functions, as seen in [Total Output Error vs. Common-Mode Voltage](#). As noted, for this graph $V_S = 12\text{ V}$; for $V_{CM} < 12\text{ V}$, the Output Error increases as V_{CM} becomes less than 12 V , with a typical maximum error of 0.005% at the most negative $V_{CM} = -16\text{ V}$.

7.4.2.3 Low V_{SENSE} Case 1

- $V_{SENSE} < 20\text{ mV}$, $-16\text{ V} \leq V_{CM} < 0$;
- Low V_{SENSE} Case 3:
- $V_{SENSE} < 20\text{ mV}$, $V_S < V_{CM} \leq 80\text{ V}$

Although the INA203 family of devices are not designed for accurate operation in either of these regions, some applications are exposed to these conditions; for example, when monitoring power supplies that are switched on and off while V_S is still applied to the INA203, INA204, or INA205. Take care to know what the behavior of the devices will be in these regions.

As V_{SENSE} approaches 0 mV , in these V_{CM} regions, the device output accuracy degrades. A larger-than-normal offset can appear at the current shunt monitor output with a typical maximum value of $V_{OUT} = 300\text{ mV}$ for $V_{SENSE} = 0\text{ mV}$. As V_{SENSE} approaches 20 mV , V_{OUT} returns to the expected output value with accuracy as specified in the *Electrical Characteristics: Current-Shunt Monitor*. [Figure 7-11](#) illustrates this effect using the INA205 (Gain = 100).

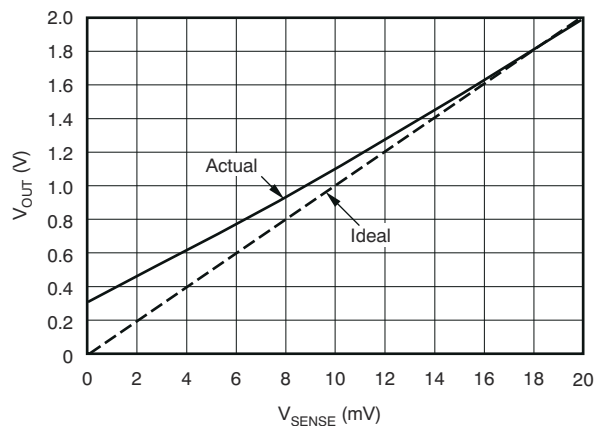
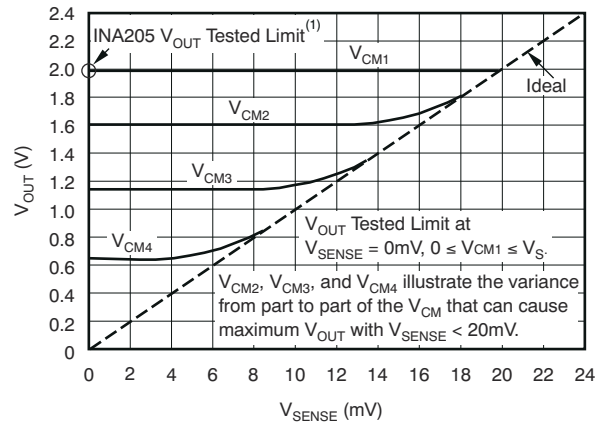

Figure 7-11. Example for Low V_{SENSE} Cases 1 and 3 (INA205, Gain = 100)

7.4.2.4 Low V_{SENSE} Case 2: $V_{SENSE} < 20\text{ mV}$, $0\text{ V} \leq V_{CM} \leq V_S$

This region of operation is the least accurate for the INA203 family. To achieve the wide input common-mode voltage range, these devices use two op amp front ends in parallel. One operational amplifier front end operates in the positive input common-mode voltage range, and the other in the negative input region. For this case, neither of these two internal amplifiers dominates and overall loop gain is very low. Within this region, V_{OUT} approaches voltages close to linear operation levels for Normal Case 2. This deviation from linear operation becomes greatest the closer V_{SENSE} approaches 0 V . Within this region, as V_{SENSE} approaches 20 mV , device operation is closer to that described by Normal Case 2. [Figure 7-12](#) illustrates this behavior for the INA205. The V_{OUT} maximum peak for this case is tested by maintaining a constant V_S , setting $V_{SENSE} = 0\text{ mV}$, and sweeping V_{CM} from 0 V to V_S . The exact V_{CM} at which V_{OUT} peaks during this test varies from part to part, but the V_{OUT} maximum peak is tested to be less than the specified V_{OUT} Tested Limit.



NOTE: (1) INA203 V_{OUT} Tested Limit = 0.4V. INA204 V_{OUT} Tested Limit = 1V.

Figure 7-12. Example For Low V_{SENSE} Case 2 (INA205, Gain = 100)

7.4.3 Transient Protection

The -16 V to 80 V common-mode range of the INA203, INA204, and INA205 is ideal for withstanding automotive fault conditions ranging from 12-V battery reversal up to 80-V transients, since no additional protective components are needed up to those levels. In the event that the INA203, INA204, and INA205 are exposed to transients on the inputs in excess of their ratings, then external transient absorption with semiconductor transient absorbers (Zeners or *Transzorbs*) are necessary. Use of metal oxide varistors (MOVs) or video disk recorders (VDRs) is not recommended except when they are used in addition to a semiconductor transient absorber. Select the transient absorber such that it will never allow the INA203, INA204, and INA205 to be exposed to transients greater than 80 V (that is, allow for transient absorber tolerance, as well as additional voltage because of transient absorber dynamic impedance). Despite the use of internal Zener-type ESD protection, the INA203, INA204, and INA205 do not lend themselves to using external resistors in series with the inputs because the internal gain resistors can vary up to $\pm 30\%$ but are closely matched. (If gain accuracy is not important, then resistors can be added in series with the INA203, INA204, and INA205 inputs with two equal resistors on each input.)

7.4.4 Output Voltage Range

The output of the INA203, INA204, and INA205 is accurate within the output voltage swing range set by the power-supply pin, V_S . This performance is best illustrated when using the INA205 (a gain of 100 version), where a 100-mV full-scale input from the shunt resistor requires an output voltage swing of 10 V, and a power-supply voltage sufficient to achieve 10 V on the output.

7.4.5 Reference

The INA203, INA204, and INA205 include an internal voltage reference that has a load regulation of 0.4 mV/mA (typical), and not more than 100 ppm/ $^{\circ}\text{C}$ of drift. Only the 14-pin package allows external access to reference voltages, where voltages of 1.2 V and 0.6 V are both available. Output current versus output voltage is illustrated in the [Typical Characteristics](#) section.

8 Application and Implementation

Note

Information in the following applications sections is not part of the TI component specification, and TI does not warrant its accuracy or completeness. TI's customers are responsible for determining suitability of components for their purposes, as well as validating and testing their design implementation to confirm system functionality.

8.1 Application Information

The INA203, INA204, and INA205 series is designed to enable easy configuration for detecting overcurrent conditions and current monitoring in an application. This device is also incorporate two open-drain comparators with internal 0.6-V references. On 14-pin versions, the comparator references can be overridden by external inputs. Comparator 1 includes a latching capability, and Comparator 2 has a user-programmable delay. 14-pin versions also provide a 1.2-V reference output. This device can also be paired with minimum additional devices to create more sophisticated monitoring functional blocks.

8.2 Typical Application

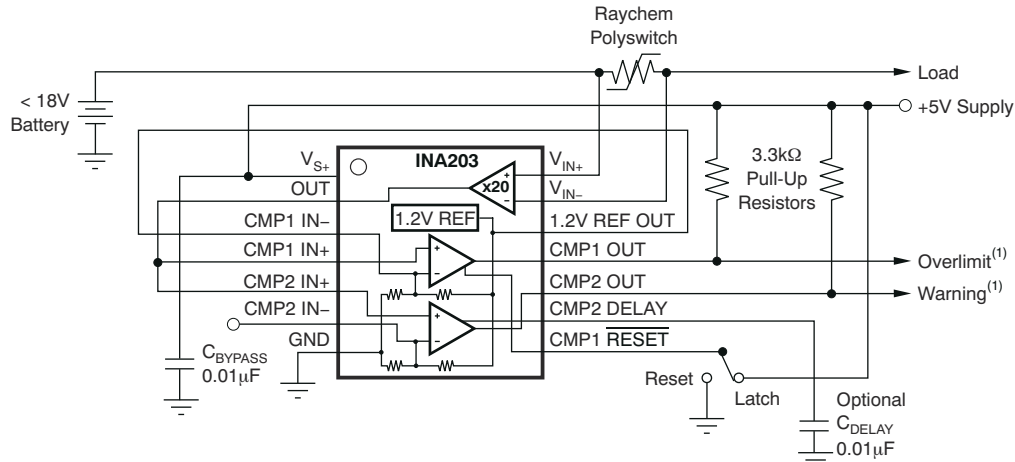

NOTE: (1) Warning at half current (with optional delay). Overlimit latches when Polyswitch opens.

Figure 8-1. Polyswitch Warning and Fault Detection Circuit

8.2.1 Design Requirements

The device measures current through a resistive shunt with current flowing in one direction, thus enabling detection of an overlimit or warning event only when the differential input voltage exceeds the corresponding threshold limits. When the current reaches the warning limit of 0.6 V, the output of CMP2 will transition high indicating a warning condition. When the current further increases to or past the overlimit limit of 1.2 V, the output of CMP1 will transition high indicating an overlimit condition. Optional C_{DELAY} can be sized to add delay to CMP1.

8.2.2 Detailed Design Procedure

Figure 8-1 shows the basic connections of the device. The input terminals, IN+ and IN-, should be connected as closely as possible to the current-sensing resistor or polymeric switch to minimize any resistance in series with the shunt resistance. Additional resistance between the current-sensing resistor and input terminals can result in errors in the measurement. When input current flows through this external input resistance, the voltage developed across the shunt resistor can differ from the voltage reaching the input terminals.

8.2.3 Application Curves

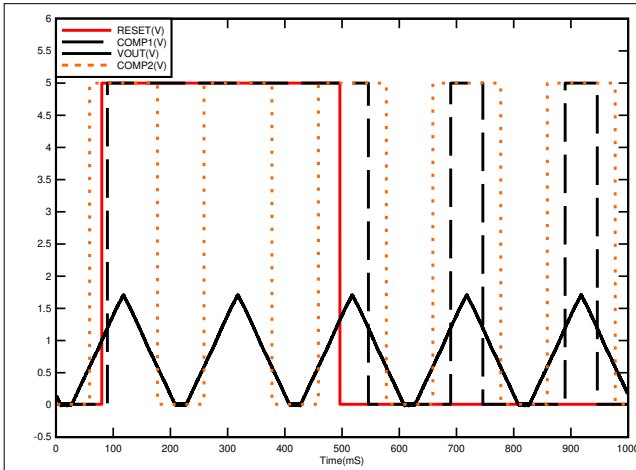

Figure 8-2. Polyswitch Warning and Fault Detection Circuit Response

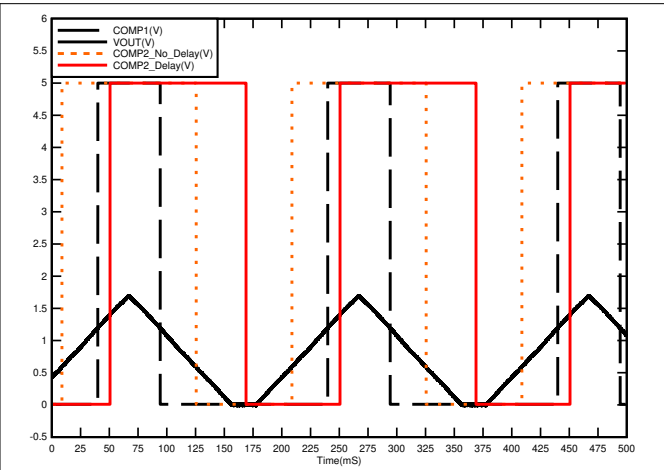

Figure 8-3. Polyswitch Warning and Fault Detection Circuit With Delay Response

9 Power Supply Recommendations

The input circuitry of the INA203, INA204, and INA205 can accurately measure beyond the power-supply voltage, V_S . For example, the V_S power supply can be 5 V, whereas the load power-supply voltage is up to 80 V. The output voltage range of the OUT terminal, however, is limited by the voltages on the power-supply pin.

10 Layout

10.1 Layout Guidelines

- Connect the input pins to the sensing resistor using a Kelvin or 4-wire connection. This connection technique ensures that only the current-sensing resistor impedance is detected between the input pins. Poor routing of the current-sensing resistor commonly results in additional resistance present between the input pins. Given the very low ohmic value of the current resistor, any additional high-current carrying impedance can cause significant measurement errors.
- The power-supply bypass capacitor should be placed as closely as possible to the supply and ground pins. The recommended value of this bypass capacitor is 0.1 μF . Additional decoupling capacitance can be added to compensate for noisy or high-impedance power supplies.

10.2 Layout Example

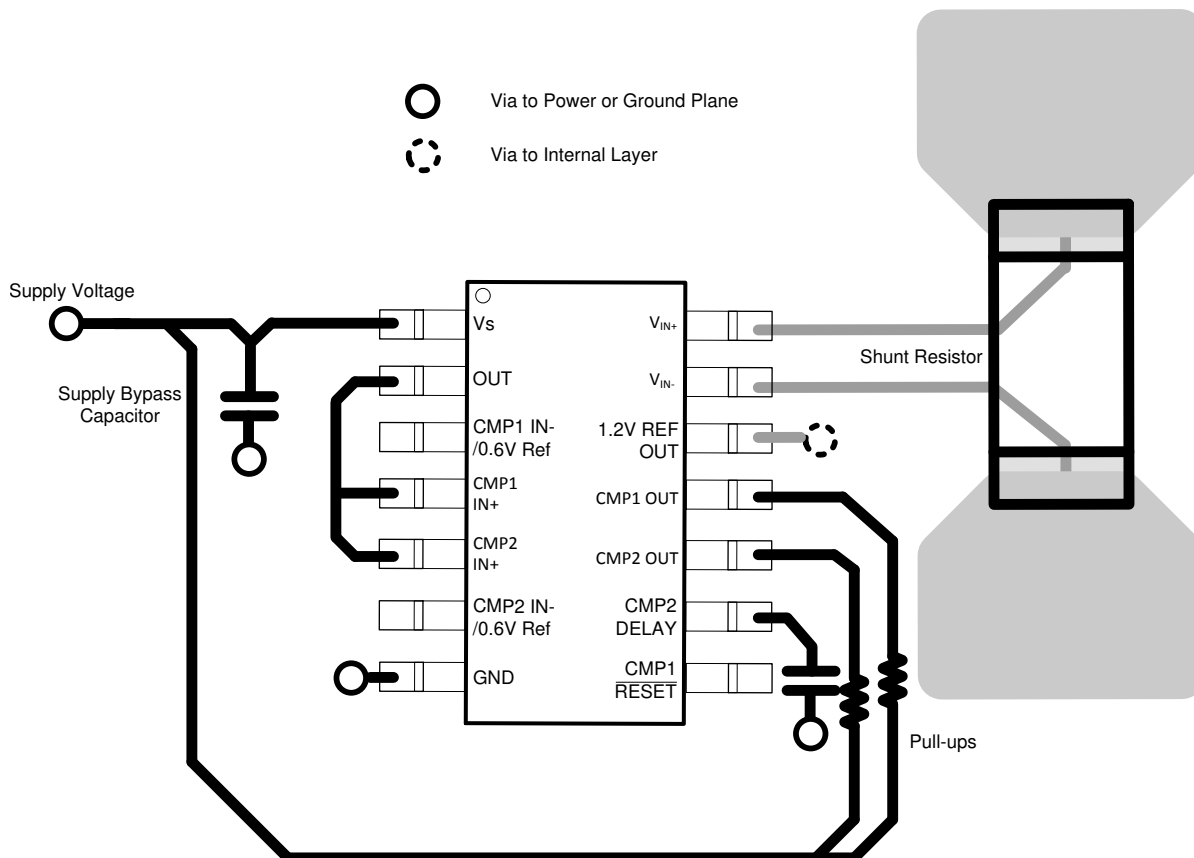

Figure 10-1. Layout Recommendation

11 Device and Documentation Support

11.1 Related Links

The table below lists quick access links. Categories include technical documents, support and community resources, tools and software, and quick access to sample or buy.

Table 11-1. Related Links

PARTS	PRODUCT FOLDER	SAMPLE & BUY	TECHNICAL DOCUMENTS	TOOLS & SOFTWARE	SUPPORT & COMMUNITY
INA203	Click here	Click here	Click here	Click here	Click here
INA204	Click here	Click here	Click here	Click here	Click here
INA205	Click here	Click here	Click here	Click here	Click here

11.2 Receiving Notification of Documentation Updates

To receive notification of documentation updates, navigate to the device product folder on [ti.com](#). Click on *Subscribe to updates* to register and receive a weekly digest of any product information that has changed. For change details, review the revision history included in any revised document.

11.3 Support Resources

[TI E2E™ support forums](#) are an engineer's go-to source for fast, verified answers and design help — straight from the experts. Search existing answers or ask your own question to get the quick design help you need.

Linked content is provided "AS IS" by the respective contributors. They do not constitute TI specifications and do not necessarily reflect TI's views; see TI's [Terms of Use](#).

11.4 Trademarks

TI E2E™ is a trademark of Texas Instruments.
All trademarks are the property of their respective owners.

11.5 Electrostatic Discharge Caution



This integrated circuit can be damaged by ESD. Texas Instruments recommends that all integrated circuits be handled with appropriate precautions. Failure to observe proper handling and installation procedures can cause damage.

ESD damage can range from subtle performance degradation to complete device failure. Precision integrated circuits may be more susceptible to damage because very small parametric changes could cause the device not to meet its published specifications.

11.6 Glossary

[TI Glossary](#) This glossary lists and explains terms, acronyms, and definitions.

12 Mechanical, Packaging, and Orderable Information

The following pages include mechanical, packaging, and orderable information. This information is the most current data available for the designated devices. This data is subject to change without notice and revision of this document. For browser-based versions of this data sheet, refer to the left-hand navigation.

PACKAGING INFORMATION

Orderable Device	Status (1)	Package Type	Package Drawing	Pins	Package Qty	Eco Plan (2)	Lead finish/ Ball material (6)	MSL Peak Temp (3)	Op Temp (°C)	Device Marking (4/5)	Samples
INA203AID	LIFEBUY	SOIC	D	14	50	RoHS & Green	NIPDAU	Level-2-260C-1 YEAR	-40 to 125	INA203A	
INA203AIDGSR	ACTIVE	VSSOP	DGS	10	2500	RoHS & Green	NIPDAU NIPDAUAG	Level-2-260C-1 YEAR	-40 to 125	BQN	Samples
INA203AIDGST	ACTIVE	VSSOP	DGS	10	250	RoHS & Green	NIPDAU NIPDAUAG	Level-2-260C-1 YEAR	-40 to 125	BQN	Samples
INA203AIDR	ACTIVE	SOIC	D	14	2500	RoHS & Green	NIPDAU	Level-2-260C-1 YEAR	-40 to 125	INA203A	Samples
INA203AIPW	ACTIVE	TSSOP	PW	14	90	RoHS & Green	NIPDAU	Level-2-260C-1 YEAR	-40 to 125	INA203A	Samples
INA203AIPWR	ACTIVE	TSSOP	PW	14	2000	RoHS & Green	NIPDAU	Level-2-260C-1 YEAR	-40 to 125	INA203A	Samples
INA204AID	LIFEBUY	SOIC	D	14	50	RoHS & Green	NIPDAU	Level-2-260C-1 YEAR	-40 to 125	INA204A	
INA204AIDGSR	ACTIVE	VSSOP	DGS	10	2500	RoHS & Green	Call TI NIPDAUAG	Level-2-260C-1 YEAR	-40 to 125	BQO	Samples
INA204AIDGST	ACTIVE	VSSOP	DGS	10	250	RoHS & Green	Call TI NIPDAUAG	Level-2-260C-1 YEAR	-40 to 125	BQO	Samples
INA204AIDR	ACTIVE	SOIC	D	14	2500	RoHS & Green	NIPDAU	Level-2-260C-1 YEAR	-40 to 125	INA204A	Samples
INA205AID	ACTIVE	SOIC	D	14	50	RoHS & Green	NIPDAU	Level-2-260C-1 YEAR	-40 to 125	INA205A	Samples
INA205AIDGSR	ACTIVE	VSSOP	DGS	10	2500	RoHS & Green	Call TI NIPDAUAG	Level-2-260C-1 YEAR	-40 to 125	BQP	Samples
INA205AIDGST	LIFEBUY	VSSOP	DGS	10	250	RoHS & Green	NIPDAU NIPDAUAG	Level-2-260C-1 YEAR	-40 to 125	BQP	
INA205AIDR	ACTIVE	SOIC	D	14	2500	RoHS & Green	NIPDAU	Level-2-260C-1 YEAR	-40 to 125	INA205A	Samples
INA205AIPW	LIFEBUY	TSSOP	PW	14	90	RoHS & Green	NIPDAU	Level-2-260C-1 YEAR	-40 to 125	INA205A	
INA205AIPWR	ACTIVE	TSSOP	PW	14	2000	RoHS & Green	NIPDAU	Level-2-260C-1 YEAR	-40 to 125	INA205A	Samples

(1) The marketing status values are defined as follows:

ACTIVE: Product device recommended for new designs.

LIFEBUY: TI has announced that the device will be discontinued, and a lifetime-buy period is in effect.

NRND: Not recommended for new designs. Device is in production to support existing customers, but TI does not recommend using this part in a new design.

PREVIEW: Device has been announced but is not in production. Samples may or may not be available.

OBSELETE: TI has discontinued the production of the device.

(2) **RoHS:** TI defines "RoHS" to mean semiconductor products that are compliant with the current EU RoHS requirements for all 10 RoHS substances, including the requirement that RoHS substance do not exceed 0.1% by weight in homogeneous materials. Where designed to be soldered at high temperatures, "RoHS" products are suitable for use in specified lead-free processes. TI may reference these types of products as "Pb-Free".

RoHS Exempt: TI defines "RoHS Exempt" to mean products that contain lead but are compliant with EU RoHS pursuant to a specific EU RoHS exemption.

Green: TI defines "Green" to mean the content of Chlorine (Cl) and Bromine (Br) based flame retardants meet JS709B low halogen requirements of ≤ 1000 ppm threshold. Antimony trioxide based flame retardants must also meet the ≤ 1000 ppm threshold requirement.

(3) MSL, Peak Temp. - The Moisture Sensitivity Level rating according to the JEDEC industry standard classifications, and peak solder temperature.

(4) There may be additional marking, which relates to the logo, the lot trace code information, or the environmental category on the device.

(5) Multiple Device Markings will be inside parentheses. Only one Device Marking contained in parentheses and separated by a "~" will appear on a device. If a line is indented then it is a continuation of the previous line and the two combined represent the entire Device Marking for that device.

(6) Lead finish/Ball material - Orderable Devices may have multiple material finish options. Finish options are separated by a vertical ruled line. Lead finish/Ball material values may wrap to two lines if the finish value exceeds the maximum column width.

Important Information and Disclaimer: The information provided on this page represents TI's knowledge and belief as of the date that it is provided. TI bases its knowledge and belief on information provided by third parties, and makes no representation or warranty as to the accuracy of such information. Efforts are underway to better integrate information from third parties. TI has taken and continues to take reasonable steps to provide representative and accurate information but may not have conducted destructive testing or chemical analysis on incoming materials and chemicals. TI and TI suppliers consider certain information to be proprietary, and thus CAS numbers and other limited information may not be available for release.

In no event shall TI's liability arising out of such information exceed the total purchase price of the TI part(s) at issue in this document sold by TI to Customer on an annual basis.

OTHER QUALIFIED VERSIONS OF INA203 :

- Automotive : [INA203-Q1](#)

NOTE: Qualified Version Definitions:

- Automotive - Q100 devices qualified for high-reliability automotive applications targeting zero defects

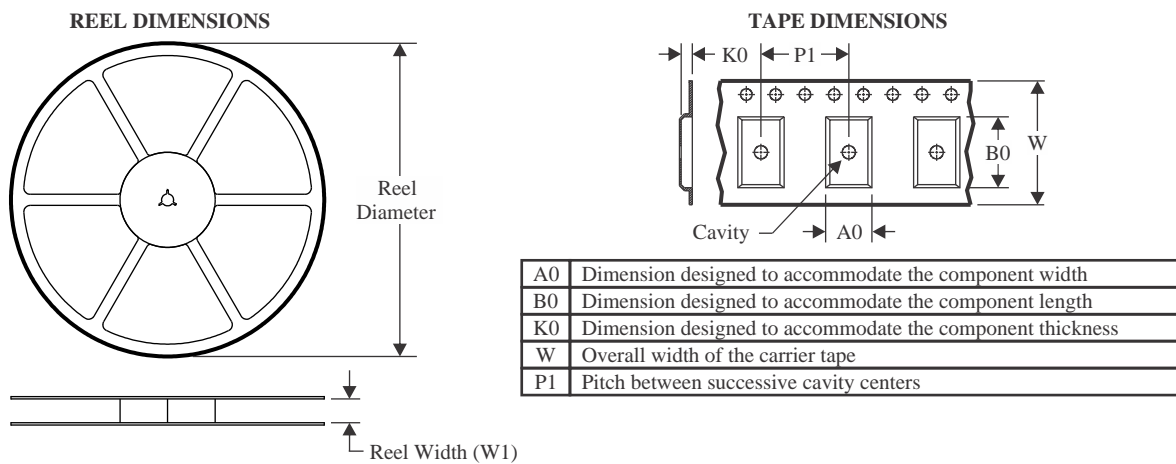
TAPE AND REEL INFORMATION

QUADRANT ASSIGNMENTS FOR PIN 1 ORIENTATION IN TAPE

*All dimensions are nominal

Device	Package Type	Package Drawing	Pins	SPQ	Reel Diameter (mm)	Reel Width W1 (mm)	A0 (mm)	B0 (mm)	K0 (mm)	P1 (mm)	W (mm)	Pin1 Quadrant
INA203AIDGSR	VSSOP	DGS	10	2500	330.0	12.4	5.3	3.4	1.4	8.0	12.0	Q1
INA203AIDR	SOIC	D	14	2500	330.0	16.4	6.5	9.0	2.1	8.0	16.0	Q1
INA203AIPWR	TSSOP	PW	14	2000	330.0	12.4	6.9	5.6	1.6	8.0	12.0	Q1
INA204AIDR	SOIC	D	14	2500	330.0	16.4	6.5	9.0	2.1	8.0	16.0	Q1
INA205AIDGST	VSSOP	DGS	10	250	180.0	12.4	5.3	3.4	1.4	8.0	12.0	Q1
INA205AIDR	SOIC	D	14	2500	330.0	16.4	6.5	9.0	2.1	8.0	16.0	Q1
INA205AIPWR	TSSOP	PW	14	2000	330.0	12.4	6.9	5.6	1.6	8.0	12.0	Q1

TAPE AND REEL BOX DIMENSIONS

*All dimensions are nominal

Device	Package Type	Package Drawing	Pins	SPQ	Length (mm)	Width (mm)	Height (mm)
INA203AIDGSR	VSSOP	DGS	10	2500	367.0	367.0	35.0
INA203AIDR	SOIC	D	14	2500	356.0	356.0	35.0
INA203AIPWR	TSSOP	PW	14	2000	367.0	367.0	35.0
INA204AIDR	SOIC	D	14	2500	356.0	356.0	35.0
INA205AIDGST	VSSOP	DGS	10	250	210.0	185.0	35.0
INA205AIDR	SOIC	D	14	2500	356.0	356.0	35.0
INA205AIPWR	TSSOP	PW	14	2000	367.0	367.0	35.0

TUBE

*All dimensions are nominal

Device	Package Name	Package Type	Pins	SPQ	L (mm)	W (mm)	T (μm)	B (mm)
INA203AID	D	SOIC	14	50	506.6	8	3940	4.32
INA203AIPW	PW	TSSOP	14	90	530	10.2	3600	3.5
INA204AID	D	SOIC	14	50	506.6	8	3940	4.32
INA205AID	D	SOIC	14	50	506.6	8	3940	4.32
INA205AIPW	PW	TSSOP	14	90	530	10.2	3600	3.5

DGS0010A



PACKAGE OUTLINE

VSSOP - 1.1 mm max height

SMALL OUTLINE PACKAGE

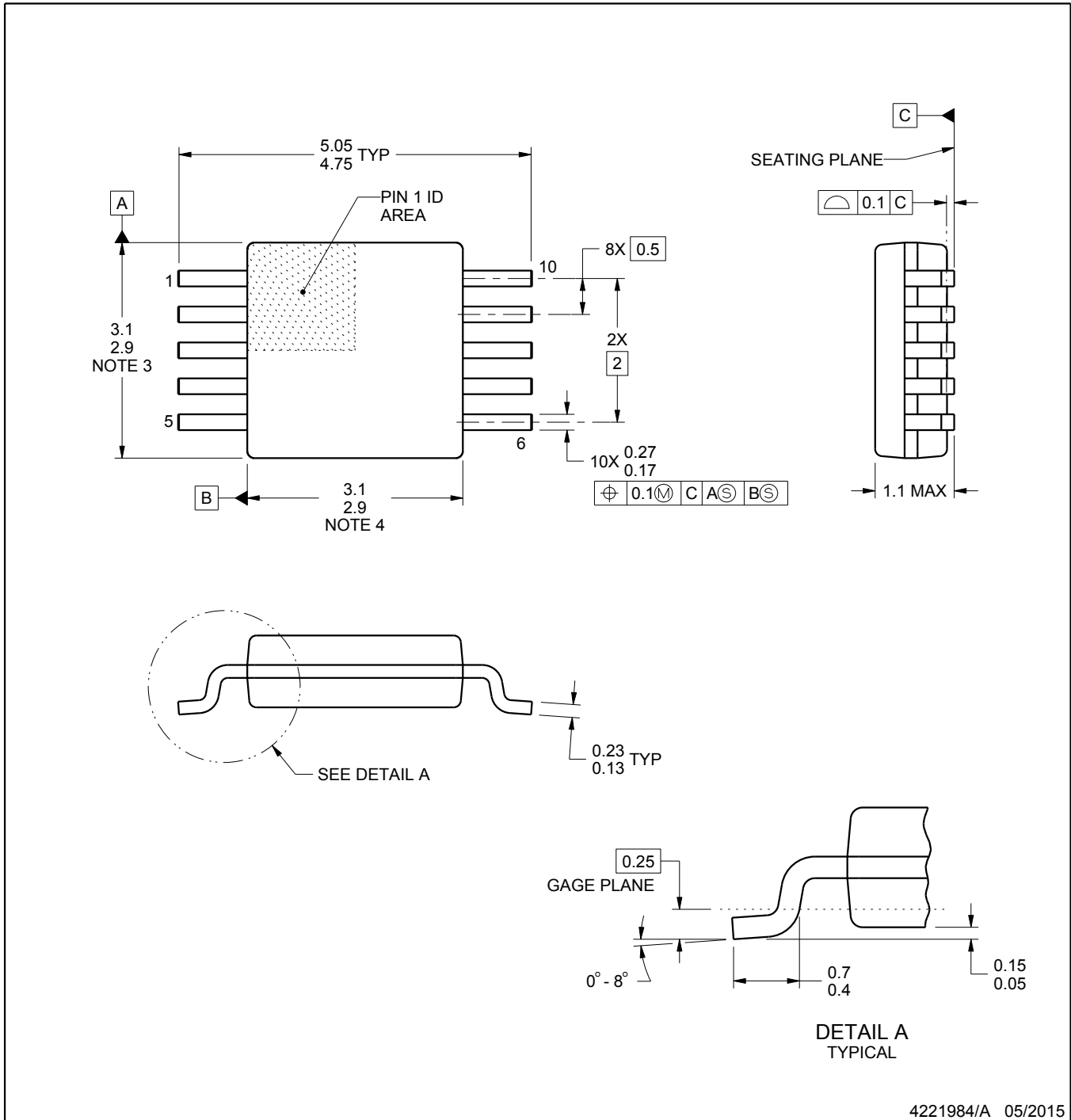

4221984/A 05/2015

NOTES:

1. All linear dimensions are in millimeters. Any dimensions in parenthesis are for reference only. Dimensioning and tolerancing per ASME Y14.5M.
2. This drawing is subject to change without notice.
3. This dimension does not include mold flash, protrusions, or gate burrs. Mold flash, protrusions, or gate burrs shall not exceed 0.15 mm per side.
4. This dimension does not include interlead flash. Interlead flash shall not exceed 0.25 mm per side.
5. Reference JEDEC registration MO-187, variation BA.

EXAMPLE BOARD LAYOUT

DGS0010A

VSSOP - 1.1 mm max height

SMALL OUTLINE PACKAGE



LAND PATTERN EXAMPLE
SCALE:10X

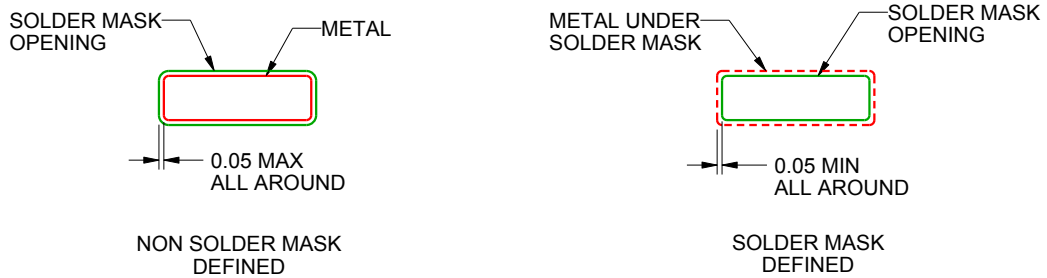

SOLDER MASK DETAILS
NOT TO SCALE

4221984/A 05/2015

NOTES: (continued)

- 6. Publication IPC-7351 may have alternate designs.
- 7. Solder mask tolerances between and around signal pads can vary based on board fabrication site.

EXAMPLE STENCIL DESIGN

DGS0010A

VSSOP - 1.1 mm max height

SMALL OUTLINE PACKAGE



SOLDER PASTE EXAMPLE
BASED ON 0.125 mm THICK STENCIL
SCALE:10X

4221984/A 05/2015

NOTES: (continued)

8. Laser cutting apertures with trapezoidal walls and rounded corners may offer better paste release. IPC-7525 may have alternate design recommendations.
9. Board assembly site may have different recommendations for stencil design.

D (R-PDSO-G14)

PLASTIC SMALL OUTLINE



- NOTES:
- A. All linear dimensions are in inches (millimeters).
 - B. This drawing is subject to change without notice.
 -  Body length does not include mold flash, protrusions, or gate burrs. Mold flash, protrusions, or gate burrs shall not exceed 0.006 (0,15) each side.
 -  Body width does not include interlead flash. Interlead flash shall not exceed 0.017 (0,43) each side.
 - E. Reference JEDEC MS-012 variation AB.

D (R-PDSO-G14)

PLASTIC SMALL OUTLINE



- NOTES:
- All linear dimensions are in millimeters.
 - This drawing is subject to change without notice.
 - Publication IPC-7351 is recommended for alternate designs.
 - Laser cutting apertures with trapezoidal walls and also rounding corners will offer better paste release. Customers should contact their board assembly site for stencil design recommendations. Refer to IPC-7525 for other stencil recommendations.
 - Customers should contact their board fabrication site for solder mask tolerances between and around signal pads.

PW (R-PDSO-G14)

PLASTIC SMALL OUTLINE



4040064-3/G 02/11

- NOTES:
- A. All linear dimensions are in millimeters. Dimensioning and tolerancing per ASME Y14.5M-1994.
 - B. This drawing is subject to change without notice.
 -  C. Body length does not include mold flash, protrusions, or gate burrs. Mold flash, protrusions, or gate burrs shall not exceed 0,15 each side.
 -  D. Body width does not include interlead flash. Interlead flash shall not exceed 0,25 each side.
 - E. Falls within JEDEC MO-153

PW (R-PDSO-G14)

PLASTIC SMALL OUTLINE



4211284-2/G 08/15

- NOTES:
- A. All linear dimensions are in millimeters.
 - B. This drawing is subject to change without notice.
 - C. Publication IPC-7351 is recommended for alternate designs.
 - D. Laser cutting apertures with trapezoidal walls and also rounding corners will offer better paste release. Customers should contact their board assembly site for stencil design recommendations. Refer to IPC-7525 for other stencil recommendations.
 - E. Customers should contact their board fabrication site for solder mask tolerances between and around signal pads.

IMPORTANT NOTICE AND DISCLAIMER

TI PROVIDES TECHNICAL AND RELIABILITY DATA (INCLUDING DATA SHEETS), DESIGN RESOURCES (INCLUDING REFERENCE DESIGNS), APPLICATION OR OTHER DESIGN ADVICE, WEB TOOLS, SAFETY INFORMATION, AND OTHER RESOURCES "AS IS" AND WITH ALL FAULTS, AND DISCLAIMS ALL WARRANTIES, EXPRESS AND IMPLIED, INCLUDING WITHOUT LIMITATION ANY IMPLIED WARRANTIES OF MERCHANTABILITY, FITNESS FOR A PARTICULAR PURPOSE OR NON-INFRINGEMENT OF THIRD PARTY INTELLECTUAL PROPERTY RIGHTS.

These resources are intended for skilled developers designing with TI products. You are solely responsible for (1) selecting the appropriate TI products for your application, (2) designing, validating and testing your application, and (3) ensuring your application meets applicable standards, and any other safety, security, regulatory or other requirements.

These resources are subject to change without notice. TI grants you permission to use these resources only for development of an application that uses the TI products described in the resource. Other reproduction and display of these resources is prohibited. No license is granted to any other TI intellectual property right or to any third party intellectual property right. TI disclaims responsibility for, and you will fully indemnify TI and its representatives against, any claims, damages, costs, losses, and liabilities arising out of your use of these resources.

TI's products are provided subject to [TI's Terms of Sale](#) or other applicable terms available either on [ti.com](https://www.ti.com) or provided in conjunction with such TI products. TI's provision of these resources does not expand or otherwise alter TI's applicable warranties or warranty disclaimers for TI products.

TI objects to and rejects any additional or different terms you may have proposed.

Mailing Address: Texas Instruments, Post Office Box 655303, Dallas, Texas 75265
Copyright © 2023, Texas Instruments Incorporated