

Product Overview

The MSMCG(J)5.0A through MXLSMCG(J)170A series of 1500 watt high-reliability Transient Voltage Suppressors (TVSs) protects a variety of voltage-sensitive components. The SMCG gull-wing design in the DO-215AB package allows for visible solder connections. The SMCJ J-bend design in the DO-214AB package allows for greater PC board mounting density. Selections include unidirectional and bidirectional as well as RoHS compliant versions. These are available with a variety of upscreening options for enhanced reliability. They can protect against the secondary effects of lightning per IEC61000-4-5 and against voltage pulses from inductive switching environments and induced by RF radiation. Since their response time is virtually instantaneous, they can also be used in protection from ESD and EFT per IEC61000-4-2 and IEC61000-4-4.

Features

- High reliability devices with fabrication and assembly lot traceability for all M prefix devices
- All devices are 100% surge tested.
- 3σ lot norm screening performed on standby current (I_D) for all M prefix devices
- Available in both unidirectional and bidirectional versions
- Suppress transients up to 1,500W at 10/1000 μ s (see [Figure 4-1](#))
- Moisture classification is “Level 1” with no dry pack required per IPC/JEDEC J-STD-020B for all M prefix devices
- Enhanced reliability screening options available in reference to MIL-PRF-19500. Refer to [High Reliability Up-Screened Plastic Products Portfolio](#) for more details on the screening options (See [Part Nomenclature](#) for all available options)
- RoHS compliant versions available
- Axial-lead equivalent packages for thru-hole mounting are available as 1.5KE6.8A to 1.5KE200CA or 1N6267 thru 1N6303A and 1N5908 (contact Microchip for other surface mount options.)

Figure 1. DO-215AB (SMCG) Package

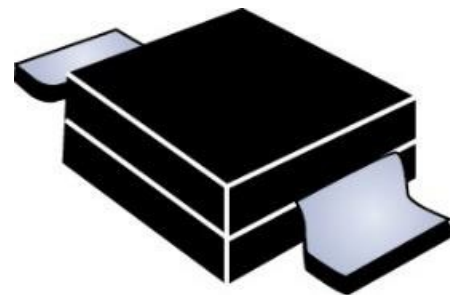

Applications/Benefits

- High-reliability devices
- Available in working stand-off voltage range of 5.0 to 170V
- Protection from switching transients and induced RF
- Protection from ESD and EFT per IEC 61000-4-2 and IEC 61000-4-4
- Secondary lightning protection per IEC61000-4-5 with 42 ohms source impedance:
 - Class 1: MSMC 5.0A to MXLSMC 170CA
 - Class 2: MSMC 5.0A to MXLSMC 150CA
 - Class 3: MSMC 5.0A to MXLSMC 75CA
 - Class 4: MSMC 5.0A to MXLSMC 36CA
- Secondary lightning protection per IEC61000-4-5 with 12 ohms source impedance:
 - Class 1: MSMC 5.0A to MXLSMC 90CA
 - Class 2: MSMC 5.0A to MXLSMC 45CA
 - Class 3: MSMC 5.0A to MXLSMC 24CA
 - Class 4: MSMC 5.0A to MXLSMC 11CA
- Secondary lightning protection per IEC61000-4-5 with 2 ohms source impedance:
 - Class 2: MSMC 5.0A to MXLSMC 22CA
 - Class 3: MSMC 5.0A to MXLSMC 10CA

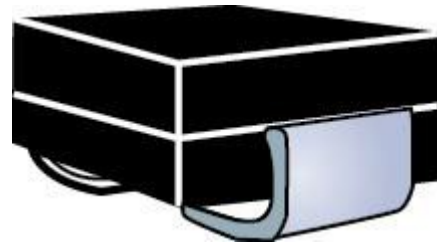
Figure 2. DO-214AB (SMCJ) Package

All SMC series are equivalent to prior SMM package identifications.

Also available:

Commercial Grade: [SMCG\(J\)5.0A – SMCG\(J\)170CAe3](#)

Axial-Lead: [M1.5KE6.8A-MXL1.5KE200CA](#)

Table of Contents

Product Overview.....	1
1. Maximum Ratings.....	4
1.1. Mechanical and Packaging.....	4
2. Part Nomenclature.....	5
2.1. Symbols and Definitions.....	5
3. Electrical Characteristics.....	6
4. Graphs.....	8
5. Package Dimensions.....	10
6. Pad Layout.....	11
7. Revision History.....	12
Microchip Information.....	13
The Microchip Website.....	13
Product Change Notification Service.....	13
Customer Support.....	13
Microchip Devices Code Protection Feature.....	13
Legal Notice.....	13
Trademarks.....	14
Quality Management System.....	15
Worldwide Sales and Service.....	16

1. Maximum Ratings

Table 1-1. Maximum Ratings

Parameters/Test Conditions		Symbol	Value	Unit
Junction and storage temperature		T_J and T_{STG}	-65 to +150	°C
Thermal resistance junction-to-lead		$R_{\theta JL}$	20	°C/W
Thermal resistance junction-to-ambient ¹		$R_{\theta JA}$	80	°C/W
Peak pulse power dissipation at 25 °C (at 10/1000 μ s, see Figure 4-1 , Figure 4-2 , and Figure 4-3)		P_{PP}	1500	W
Impulse repetition rate (duty factor)		df	0.01	%
$t_{clamping}$ (0 volts to V(BR) min.)	Unidirectional	$t_{clamping}$	< 100	ps
	Bidirectional		< 5	ns
Average power dissipation	TL = +30 °C	$P_{M(AV)}$	6	W
	TA = +25 °C		1.56 ¹	
Maximum forward surge current ²		I_{FSM}	200	A (pk)
Solder temperature at 10 s		T_{SP}	260	°C

Notes:

1. When mounted on FR4 PC board (1 oz Cu) with recommended footprint
2. Peak impulse of 8.3 ms half-sine wave at 25 °C (unidirectional only)

1.1 Mechanical and Packaging

- Case: Void-free transfer molded thermosetting epoxy body meeting UL94V-0
- Terminals: Tin-lead or RoHS compliant annealed matte-tin plating. Solderable to MIL-STD-750, method 2026
- Marking: Reliability level, part number, and date code
- Polarity: Cathode indicated by band. No cathode band on bi-directional devices
- Tape and reel option: Standard per EIA-481-2 with 16 mm tape (add "TR" suffix to part number). Consult factory for quantities.
- Weight: Approximately 0.25 grams
- See [Package Dimensions](#)

2. Part Nomenclature

Figure 2-1. Part Nomenclature

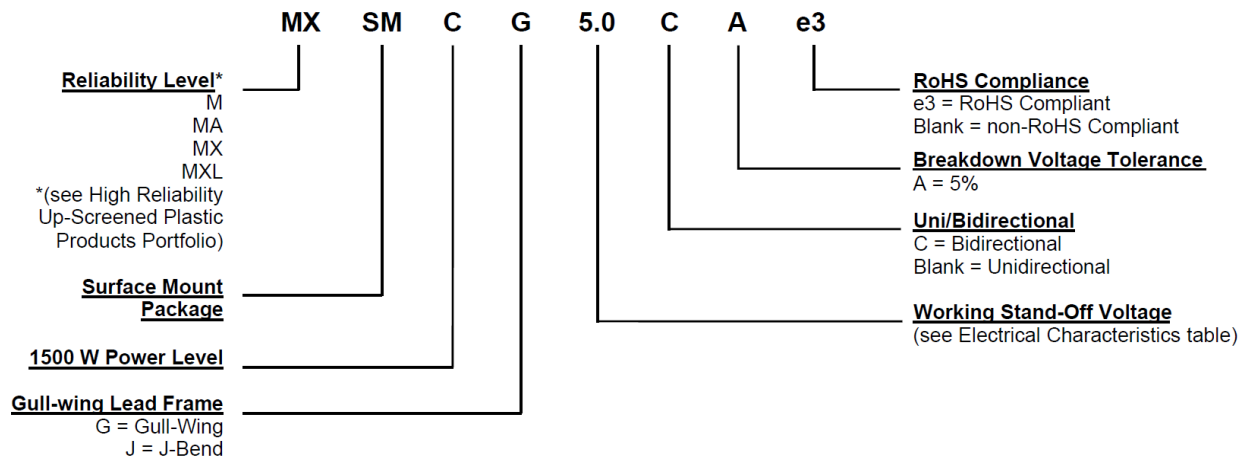

2.1 Symbols and Definitions

Table 2-1. Symbols and Definitions

Symbol	Definition
$I_{(BR)}$	Breakdown current: The current used for measuring breakdown voltage $V_{(BR)}$.
I_D	Standby current: The current at the rated stand-off voltage (V_{WM}).
I_F	Forward current: The forward current DC value, no alternating component.
I_{PP}	Peak impulse current: The peak current during the impulse.
P_{PP}	Peak pulse power: The peak power that can be applied for a specific pulse width and waveform. The product of V_C and I_{PP} .
$V_{(BR)}$	Breakdown voltage: The voltage across the device at a specified current $I_{(BR)}$ in the breakdown region.
V_C	Clamping voltage: The voltage across the device in a region of low differential resistance during the application of an impulse current (I_{PP}) for a specified waveform.
V_{WM}	Working stand-off voltage: The maximum-rated value of DC or repetitive peak positive cathode to anode voltage that may be continuously applied over the standard operating temperature.

3. Electrical Characteristics

Table 3-1. Electrical Characteristics at 25 °C Unless Otherwise Stated

Microchip Part Number		Working Stand-Off Voltage V_{WM} Volts	Breakdown Voltage $V_{(BR)}$ at $I_{(BR)}$ Volts		Maximum Clamping Voltage at I_{PP} Volts	Peak Impulse Current at 10/1000 μs (See Figure 4-2) I_{PP} Amps	Maximum Standby Current at V_{WM} I_D μA	
Gull-Wing	J-Bend		Min.	Max.				$I_{(BR)}$ mA
MSMCG5.0(C)A	MSMCJ5.0(C)A	5.0	6.40	7.00	10	9.2	163.0	1000
MSMCG6.0(C)A	MSMCJ6.0(C)A	6.0	6.67	7.37	10	10.3	145.6	1000
MSMCG6.5(C)A	MSMCJ6.5(C)A	6.5	7.22	7.98	10	11.2	133.9	500
MSMCG7.0(C)A	MSMCJ7.0(C)A	7.0	7.78	8.60	10	12.0	125.0	200
MSMCG7.5(C)A	MSMCJ7.5(C)A	7.5	8.33	9.21	1	12.9	116.3	100
MSMCG8.0(C)A	MSMCJ8.0(C)A	8.0	8.89	9.83	1	13.6	110.3	50
MSMCG8.5(C)A	MSMCJ8.5(C)A	8.5	9.44	10.4	1	14.4	104.2	20
MSMCG9.0(C)A	MSMCJ9.0(C)A	9.0	10.0	11.1	1	15.4	97.4	10
MSMCG10(C)A	MSMCJ10(C)A	10	11.1	12.3	1	17.0	88.2	5
MSMCG11(C)A	MSMCJ11(C)A	11	12.2	13.5	1	18.2	82.4	5
MSMCG12(C)A	MSMCJ12(C)A	12	13.3	14.7	1	19.9	75.3	5
MSMCG13(C)A	MSMCJ13(C)A	13	14.4	15.9	1	21.5	69.7	1
MSMCG14(C)A	MSMCJ14(C)A	14	15.6	17.2	1	23.2	64.7	1
MSMCG15(C)A	MSMCJ15(C)A	15	16.7	18.5	1	24.4	61.5	1
MSMCG16(C)A	MSMCJ16(C)A	16	17.8	19.7	1	26.0	57.7	1
MSMCG17(C)A	MSMCJ17(C)A	17	18.9	20.9	1	27.6	53.3	1
MSMCG18(C)A	MSMCJ18(C)A	18	20.0	22.1	1	29.2	51.4	1
MSMCG20(C)A	MSMCJ20(C)A	20	22.2	24.5	1	32.4	46.3	1
MSMCG22(C)A	MSMCJ22(C)A	22	24.4	26.9	1	35.5	42.2	1
MSMCG24(C)A	MSMCJ24(C)A	24	26.7	29.5	1	38.9	38.6	1
MSMCG26(C)A	MSMCJ26(C)A	26	28.9	31.9	1	42.1	35.6	1
MSMCG28(C)A	MSMCJ28(C)A	28	31.1	34.4	1	45.4	33.0	1
MSMCG30(C)A	MSMCJ30(C)A	30	33.3	36.8	1	48.4	31.0	1
MSMCG33(C)A	MSMCJ33(C)A	33	36.7	40.6	1	53.3	28.1	1
MSMCG36(C)A	MSMCJ36(C)A	36	40.0	44.2	1	58.1	25.8	1
MSMCG40(C)A	MSMCJ40(C)A	40	44.4	49.1	1	64.5	23.2	1
MSMCG43(C)A	MSMCJ43(C)A	43	47.8	52.8	1	69.4	21.6	1
MSMCG45(C)A	MSMCJ45(C)A	45	50.0	55.3	1	72.7	20.6	1
MSMCG48(C)A	MSMCJ48(C)A	48	53.3	58.9	1	77.4	19.4	1
MSMCG51(C)A	MSMCJ51(C)A	51	56.7	62.7	1	82.4	18.2	1
MSMCG54(C)A	MSMCJ54(C)A	54	60.0	66.3	1	87.1	17.2	1
MSMCG58(C)A	MSMCJ58(C)A	58	64.4	71.2	1	93.6	16.0	1

.....continued

Microchip Part Number		Working Stand-Off Voltage V_{WM} Volts	Breakdown Voltage $V_{(BR)}$ at $I_{(BR)}$ Volts		Maximum Clamping Voltage at I_{PP} Volts	Peak Impulse Current at 10/1000 μ s (See Figure 4-2) I_{PP} Amps	Maximum Standby Current at V_{WM} I_D μ A	
Gull-Wing	J-Bend		Min.	Max.				$I_{(BR)}$ mA
MSMCG60(C)A	MSMCJ60(C)A	60	66.7	73.7	1	96.8	15.5	1
MSMCG64(C)A	MSMCJ64(C)A	64	71.1	78.6	1	103.0	14.6	1
MSMCG70(C)A	MSMCJ70(C)A	70	77.8	86.0	1	113	13.3	1
MSMCG75(C)A	MSMCJ75(C)A	75	83.3	92.1	1	121	12.4	1
MSMCG78(C)A	MSMCJ78(C)A	78	86.7	95.8	1	126	11.4	1
MSMCG85(C)A	MSMCJ85(C)A	85	94.4	104.0	1	137	10.4	1
MSMCG90(C)A	MSMCJ90(C)A	90	100	111	1	146	10.3	1
MSMCG100(C)A	MSMCJ100(C)A	100	111	123	1	162	9.3	1
MSMCG110(C)A	MSMCJ110(C)A	110	122	135	1	177	8.4	1
MSMCG120(C)A	MSMCJ120(C)A	120	133	147	1	193	7.8	1
MSMCG130(C)A	MSMCJ130(C)A	130	144	159	1	209	7.2	1
MSMCG150(C)A	MSMCJ150(C)A	150	167	185	1	243	6.2	1
MSMCG160(C)A	MSMCJ160(C)A	160	178	197	1	259	5.8	1
MSMCG170(C)A	MSMCJ170(C)A	170	189	209	1	275	5.5	1

4. Graphs

Figure 4-1. Peak Pulse Power Vs. Pulse Time

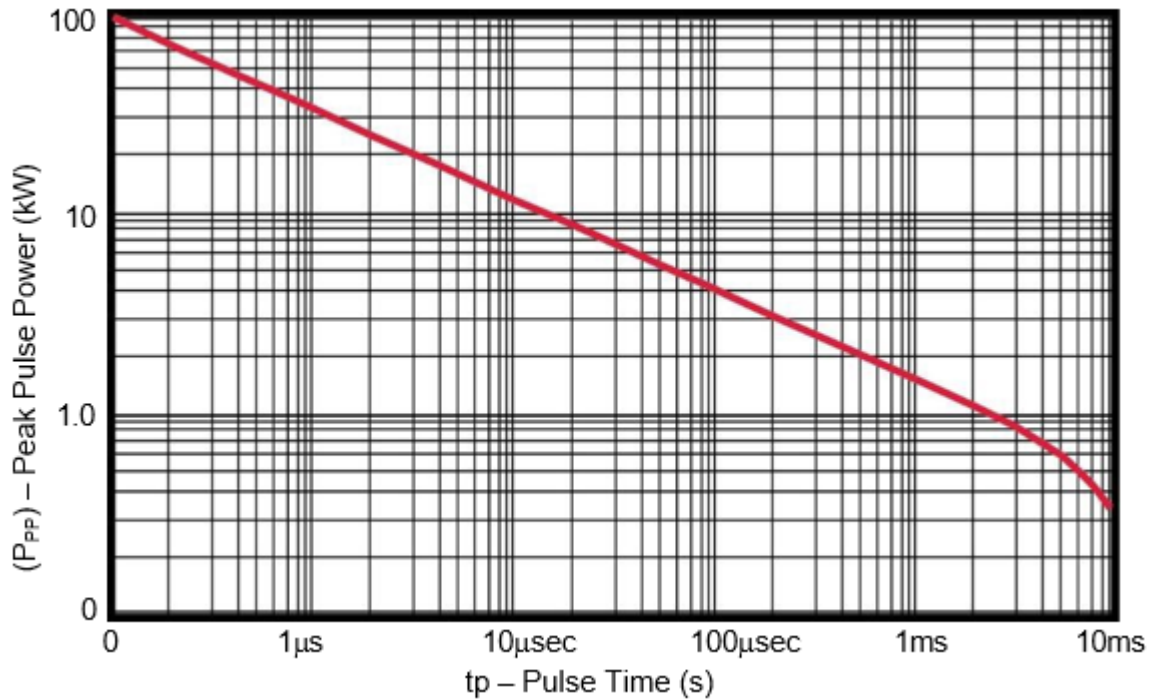

Figure 4-2. Pulse Waveform

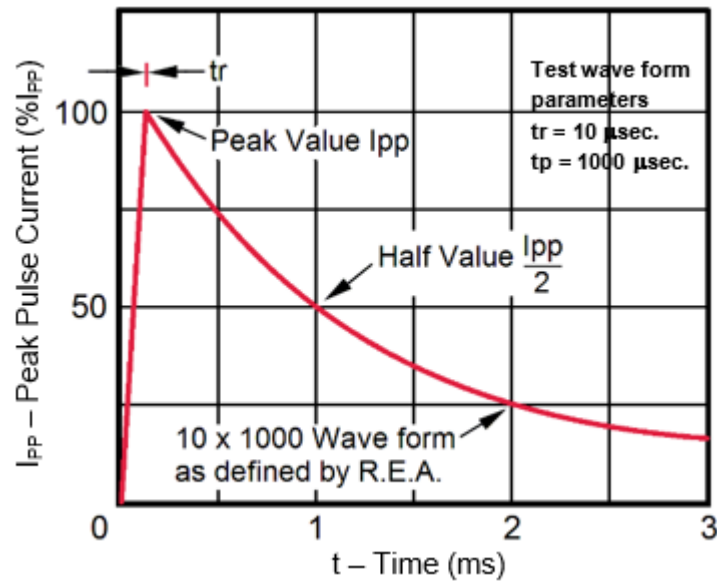

Figure 4-3. Derating Curve

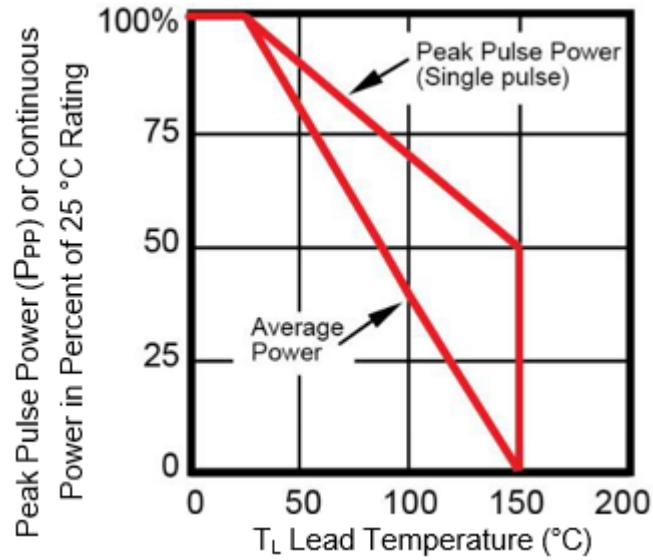
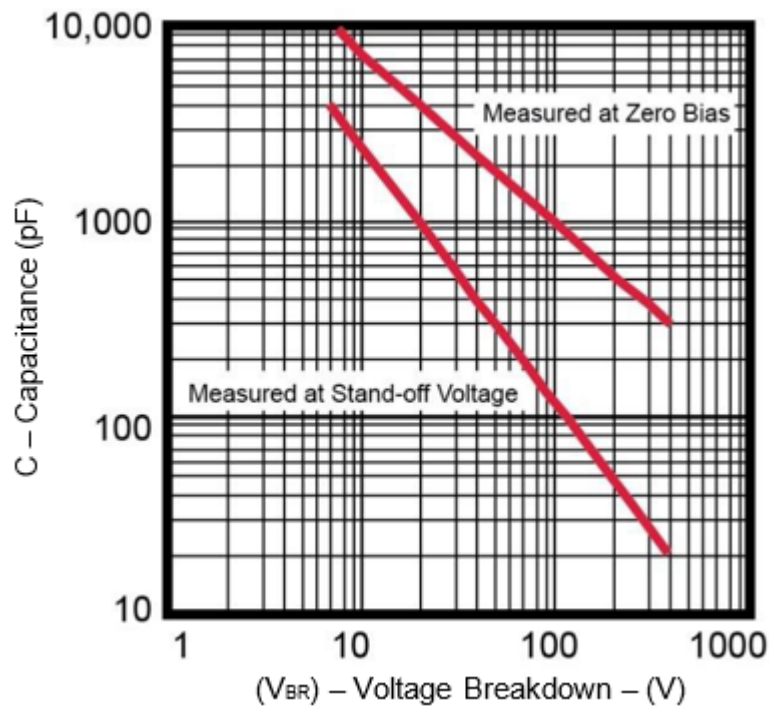

Figure 4-4. Typical Capacitance Vs. Breakdown Voltage (Unidirectional Configuration)¹



Note:

1. Bidirectional capacitance is half that shown at zero volts.

5. Package Dimensions

Figure 5-1. SMCG (DO-215AB)

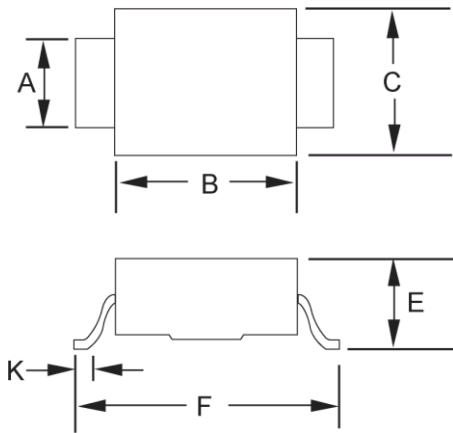

Ltr	Dimensions			
	Inch		Millimeters	
	Min.	Max.	Min.	Max.
A	0.115	0.121	2.92	3.07
B	0.260	0.280	6.60	7.11
C	0.220	0.245	5.59	6.22
E ¹	0.077	0.110	1.95	2.80
F	0.380	0.400	9.65	10.16
K	0.025	0.040	0.635	1.016

Note:

1. Dimension "E" exceeds the JEDEC outline as shown. Typical stand-off height: 0.004"–0.008" (0.1 mm – 0.2 mm).

Figure 5-2. SMCJ (DO-214AB)

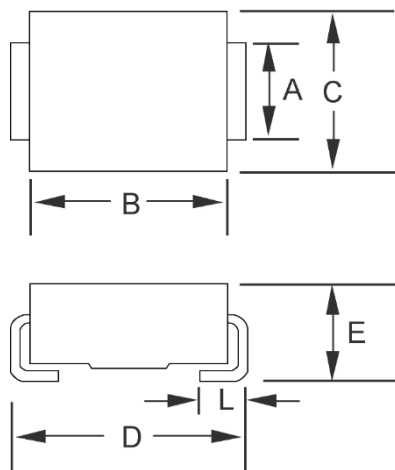

Ltr	Dimensions			
	Inch		Millimeters	
	Min.	Max.	Min.	Max.
A	0.115	0.121	2.92	3.07
B	0.260	0.280	6.60	7.11
C	0.220	0.245	5.59	6.22
D	0.305	0.320	7.75	8.13
E ¹	0.077	0.110	1.95	2.80
L	0.030	0.060	0.760	1.52

Note:

1. Dimension "E" exceeds the JEDEC outline in height as shown. Typical stand-off height: 0.004"–0.008" (0.1 mm – 0.2 mm).

6. Pad Layout

Figure 6-1. Pad Layout

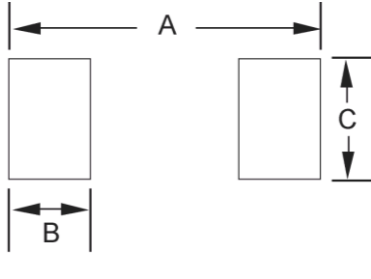

SMCG (DO-215AB)		
Ltr	Inch	Millimeters
A	0.510	12.95
B	0.110	2.79
C	0.150	3.81

SMCJ (DO-214AB)		
Ltr	Inch	Millimeters
A	0.390	9.90
B	0.110	2.79
C	0.150	3.81

7. Revision History

The revision history describes the changes that were implemented in the document. The changes are listed by revision, starting with the most current publication.

Revision	Date	Description
A	10/2023	Initial revision.

Microchip Information

The Microchip Website

Microchip provides online support via our website at www.microchip.com/. This website is used to make files and information easily available to customers. Some of the content available includes:

- **Product Support** – Data sheets and errata, application notes and sample programs, design resources, user’s guides and hardware support documents, latest software releases and archived software
- **General Technical Support** – Frequently Asked Questions (FAQs), technical support requests, online discussion groups, Microchip design partner program member listing
- **Business of Microchip** – Product selector and ordering guides, latest Microchip press releases, listing of seminars and events, listings of Microchip sales offices, distributors and factory representatives

Product Change Notification Service

Microchip’s product change notification service helps keep customers current on Microchip products. Subscribers will receive email notification whenever there are changes, updates, revisions or errata related to a specified product family or development tool of interest.

To register, go to www.microchip.com/pcn and follow the registration instructions.

Customer Support

Users of Microchip products can receive assistance through several channels:

- Distributor or Representative
- Local Sales Office
- Embedded Solutions Engineer (ESE)
- Technical Support

Customers should contact their distributor, representative or ESE for support. Local sales offices are also available to help customers. A listing of sales offices and locations is included in this document.

Technical support is available through the website at: www.microchip.com/support

Microchip Devices Code Protection Feature

Note the following details of the code protection feature on Microchip products:

- Microchip products meet the specifications contained in their particular Microchip Data Sheet.
- Microchip believes that its family of products is secure when used in the intended manner, within operating specifications, and under normal conditions.
- Microchip values and aggressively protects its intellectual property rights. Attempts to breach the code protection features of Microchip product is strictly prohibited and may violate the Digital Millennium Copyright Act.
- Neither Microchip nor any other semiconductor manufacturer can guarantee the security of its code. Code protection does not mean that we are guaranteeing the product is “unbreakable”. Code protection is constantly evolving. Microchip is committed to continuously improving the code protection features of our products.

Legal Notice

This publication and the information herein may be used only with Microchip products, including to design, test, and integrate Microchip products with your application. Use of this information in any other manner violates these terms. Information regarding device applications is provided only for your convenience and may be superseded by updates. It is your responsibility to ensure

that your application meets with your specifications. Contact your local Microchip sales office for additional support or, obtain additional support at www.microchip.com/en-us/support/design-help/client-support-services.

THIS INFORMATION IS PROVIDED BY MICROCHIP "AS IS". MICROCHIP MAKES NO REPRESENTATIONS OR WARRANTIES OF ANY KIND WHETHER EXPRESS OR IMPLIED, WRITTEN OR ORAL, STATUTORY OR OTHERWISE, RELATED TO THE INFORMATION INCLUDING BUT NOT LIMITED TO ANY IMPLIED WARRANTIES OF NON-INFRINGEMENT, MERCHANTABILITY, AND FITNESS FOR A PARTICULAR PURPOSE, OR WARRANTIES RELATED TO ITS CONDITION, QUALITY, OR PERFORMANCE.

IN NO EVENT WILL MICROCHIP BE LIABLE FOR ANY INDIRECT, SPECIAL, PUNITIVE, INCIDENTAL, OR CONSEQUENTIAL LOSS, DAMAGE, COST, OR EXPENSE OF ANY KIND WHATSOEVER RELATED TO THE INFORMATION OR ITS USE, HOWEVER CAUSED, EVEN IF MICROCHIP HAS BEEN ADVISED OF THE POSSIBILITY OR THE DAMAGES ARE FORESEEABLE. TO THE FULLEST EXTENT ALLOWED BY LAW, MICROCHIP'S TOTAL LIABILITY ON ALL CLAIMS IN ANY WAY RELATED TO THE INFORMATION OR ITS USE WILL NOT EXCEED THE AMOUNT OF FEES, IF ANY, THAT YOU HAVE PAID DIRECTLY TO MICROCHIP FOR THE INFORMATION.

Use of Microchip devices in life support and/or safety applications is entirely at the buyer's risk, and the buyer agrees to defend, indemnify and hold harmless Microchip from any and all damages, claims, suits, or expenses resulting from such use. No licenses are conveyed, implicitly or otherwise, under any Microchip intellectual property rights unless otherwise stated.

Trademarks

The Microchip name and logo, the Microchip logo, Adaptec, AVR, AVR logo, AVR Freaks, BesTime, BitCloud, CryptoMemory, CryptoRF, dsPIC, flexPWR, HELDO, IGLOO, JukeBlox, KeeLoq, Kleer, LANCheck, LinkMD, maXStylus, maXTouch, MediaLB, megaAVR, Microsemi, Microsemi logo, MOST, MOST logo, MPLAB, OptoLyzer, PIC, picoPower, PICSTART, PIC32 logo, PolarFire, Prochip Designer, QTouch, SAM-BA, SenGenuity, SpyNIC, SST, SST Logo, SuperFlash, Symmetricom, SyncServer, Tachyon, TimeSource, tinyAVR, UNI/O, Vectron, and XMEGA are registered trademarks of Microchip Technology Incorporated in the U.S.A. and other countries.

AgileSwitch, ClockWorks, The Embedded Control Solutions Company, EtherSynch, Flashtec, Hyper Speed Control, HyperLight Load, Libero, motorBench, mTouch, Powermite 3, Precision Edge, ProASIC, ProASIC Plus, ProASIC Plus logo, Quiet-Wire, SmartFusion, SyncWorld, TimeCesium, TimeHub, TimePictra, TimeProvider, and ZL are registered trademarks of Microchip Technology Incorporated in the U.S.A.

Adjacent Key Suppression, AKS, Analog-for-the-Digital Age, Any Capacitor, AnyIn, AnyOut, Augmented Switching, BlueSky, BodyCom, Clockstudio, CodeGuard, CryptoAuthentication, CryptoAutomotive, CryptoCompanion, CryptoController, dsPICDEM, dsPICDEM.net, Dynamic Average Matching, DAM, ECAN, Espresso T1S, EtherGREEN, EyeOpen, GridTime, IdealBridge, IGaT, In-Circuit Serial Programming, ICSP, INICnet, Intelligent Paralleling, IntelliMOS, Inter-Chip Connectivity, JitterBlocker, Knob-on-Display, MarginLink, maxCrypto, maxView, memBrain, Mindi, MiWi, MPASM, MPF, MPLAB Certified logo, MPLIB, MPLINK, mSiC, MultiTRAK, NetDetach, Omniscient Code Generation, PICDEM, PICDEM.net, PICKit, PICtail, Power MOS IV, Power MOS 7, PowerSmart, PureSilicon, QMatrix, REAL ICE, Ripple Blocker, RTAX, RTG4, SAM-ICE, Serial Quad I/O, simpleMAP, SimpliPHY, SmartBuffer, SmartHLS, SMART-I.S., storClad, SQI, SuperSwitcher, SuperSwitcher II, Switchtec, SynchroPHY, Total Endurance, Trusted Time, TSHARC, Turing, USBCheck, VariSense, VectorBlox, VeriPHY, ViewSpan, WiperLock, XpressConnect, and ZENA are trademarks of Microchip Technology Incorporated in the U.S.A. and other countries.

SQTP is a service mark of Microchip Technology Incorporated in the U.S.A.

The Adaptec logo, Frequency on Demand, Silicon Storage Technology, and Symmcom are registered trademarks of Microchip Technology Inc. in other countries.

GestIC is a registered trademark of Microchip Technology Germany II GmbH & Co. KG, a subsidiary of Microchip Technology Inc., in other countries.

All other trademarks mentioned herein are property of their respective companies.

© 2021-2023, Microchip Technology Incorporated and its subsidiaries. All Rights Reserved.

ISBN: 978-1-6683-3329-7

Quality Management System

For information regarding Microchip's Quality Management Systems, please visit www.microchip.com/quality.

Worldwide Sales and Service

AMERICAS	ASIA/PACIFIC	ASIA/PACIFIC	EUROPE
<p>Corporate Office 2355 West Chandler Blvd. Chandler, AZ 85224-6199 Tel: 480-792-7200 Fax: 480-792-7277 Technical Support: www.microchip.com/support Web Address: www.microchip.com</p> <p>Atlanta Duluth, GA Tel: 678-957-9614 Fax: 678-957-1455</p> <p>Austin, TX Tel: 512-257-3370</p> <p>Boston Westborough, MA Tel: 774-760-0087 Fax: 774-760-0088</p> <p>Chicago Itasca, IL Tel: 630-285-0071 Fax: 630-285-0075</p> <p>Dallas Addison, TX Tel: 972-818-7423 Fax: 972-818-2924</p> <p>Detroit Novi, MI Tel: 248-848-4000</p> <p>Houston, TX Tel: 281-894-5983</p> <p>Indianapolis Noblesville, IN Tel: 317-773-8323 Fax: 317-773-5453 Tel: 317-536-2380</p> <p>Los Angeles Mission Viejo, CA Tel: 949-462-9523 Fax: 949-462-9608 Tel: 951-273-7800</p> <p>Raleigh, NC Tel: 919-844-7510</p> <p>New York, NY Tel: 631-435-6000</p> <p>San Jose, CA Tel: 408-735-9110 Tel: 408-436-4270</p> <p>Canada - Toronto Tel: 905-695-1980 Fax: 905-695-2078</p>	<p>Australia - Sydney Tel: 61-2-9868-6733</p> <p>China - Beijing Tel: 86-10-8569-7000</p> <p>China - Chengdu Tel: 86-28-8665-5511</p> <p>China - Chongqing Tel: 86-23-8980-9588</p> <p>China - Dongguan Tel: 86-769-8702-9880</p> <p>China - Guangzhou Tel: 86-20-8755-8029</p> <p>China - Hangzhou Tel: 86-571-8792-8115</p> <p>China - Hong Kong SAR Tel: 852-2943-5100</p> <p>China - Nanjing Tel: 86-25-8473-2460</p> <p>China - Qingdao Tel: 86-532-8502-7355</p> <p>China - Shanghai Tel: 86-21-3326-8000</p> <p>China - Shenyang Tel: 86-24-2334-2829</p> <p>China - Shenzhen Tel: 86-755-8864-2200</p> <p>China - Suzhou Tel: 86-186-6233-1526</p> <p>China - Wuhan Tel: 86-27-5980-5300</p> <p>China - Xian Tel: 86-29-8833-7252</p> <p>China - Xiamen Tel: 86-592-2388138</p> <p>China - Zhuhai Tel: 86-756-3210040</p>	<p>India - Bangalore Tel: 91-80-3090-4444</p> <p>India - New Delhi Tel: 91-11-4160-8631</p> <p>India - Pune Tel: 91-20-4121-0141</p> <p>Japan - Osaka Tel: 81-6-6152-7160</p> <p>Japan - Tokyo Tel: 81-3-6880-3770</p> <p>Korea - Daegu Tel: 82-53-744-4301</p> <p>Korea - Seoul Tel: 82-2-554-7200</p> <p>Malaysia - Kuala Lumpur Tel: 60-3-7651-7906</p> <p>Malaysia - Penang Tel: 60-4-227-8870</p> <p>Philippines - Manila Tel: 63-2-634-9065</p> <p>Singapore Tel: 65-6334-8870</p> <p>Taiwan - Hsin Chu Tel: 886-3-577-8366</p> <p>Taiwan - Kaohsiung Tel: 886-7-213-7830</p> <p>Taiwan - Taipei Tel: 886-2-2508-8600</p> <p>Thailand - Bangkok Tel: 66-2-694-1351</p> <p>Vietnam - Ho Chi Minh Tel: 84-28-5448-2100</p>	<p>Austria - Wels Tel: 43-7242-2244-39 Fax: 43-7242-2244-393</p> <p>Denmark - Copenhagen Tel: 45-4485-5910 Fax: 45-4485-2829</p> <p>Finland - Espoo Tel: 358-9-4520-820</p> <p>France - Paris Tel: 33-1-69-53-63-20 Fax: 33-1-69-30-90-79</p> <p>Germany - Garching Tel: 49-8931-9700</p> <p>Germany - Haan Tel: 49-2129-3766400</p> <p>Germany - Heilbronn Tel: 49-7131-72400</p> <p>Germany - Karlsruhe Tel: 49-721-625370</p> <p>Germany - Munich Tel: 49-89-627-144-0 Fax: 49-89-627-144-44</p> <p>Germany - Rosenheim Tel: 49-8031-354-560</p> <p>Israel - Ra'anana Tel: 972-9-744-7705</p> <p>Italy - Milan Tel: 39-0331-742611 Fax: 39-0331-466781</p> <p>Italy - Padova Tel: 39-049-7625286</p> <p>Netherlands - Drunen Tel: 31-416-690399 Fax: 31-416-690340</p> <p>Norway - Trondheim Tel: 47-72884388</p> <p>Poland - Warsaw Tel: 48-22-3325737</p> <p>Romania - Bucharest Tel: 40-21-407-87-50</p> <p>Spain - Madrid Tel: 34-91-708-08-90 Fax: 34-91-708-08-91</p> <p>Sweden - Gothenberg Tel: 46-31-704-60-40</p> <p>Sweden - Stockholm Tel: 46-8-5090-4654</p> <p>UK - Wokingham Tel: 44-118-921-5800 Fax: 44-118-921-5820</p>