

## Three-Output Low Power MEMS Clock Generator

### Features

- MEMS-Based Clock Generator Eliminates the Need for External Crystal or Reference Clock
- Three LVCMOS Output Clocks: 2 kHz to 100 MHz
- Low Power Consumption: 5.2 mA (All Outputs Active)
- Wide Supply Voltage Range: 1.71V to 3.63V
- Ultra-Small Package Sizes:
  - 1.6 mm x 1.2 mm
  - 2.0 mm x 1.6 mm
  - 2.5 mm x 2.0 mm
- High Frequency Stability:  $\pm 20$  ppm,  $\pm 25$  ppm,  $\pm 50$  ppm
- Wide Temperature Range:
  - Automotive:  $-40^{\circ}\text{C}$  to  $+125^{\circ}\text{C}$
  - Ext. Industrial:  $-40^{\circ}\text{C}$  to  $+105^{\circ}\text{C}$
  - Industrial:  $-40^{\circ}\text{C}$  to  $+85^{\circ}\text{C}$
  - Commercial:  $-20^{\circ}\text{C}$  to  $+70^{\circ}\text{C}$
- Excellent Shock and Vibration Immunity:
  - Shock: Qualified to MIL-STD-883E Method 2002.3, Test Condition G (30,000g)
  - Vibration: Qualified to MIL-STD-883E Method 2007.2, Test Condition C (70g)
- High Reliability
- Lead-Free and RoHS-Compliant
- Automotive Option AEC-Q100 Available

### Applications

- Low Power/Portable Applications: IoT, Embedded/Smart Devices
- Consumer: Home Healthcare, Fitness Devices, Home Automation
- Industrial: Building/Factory Automation, Surveillance Cameras

### General Description

The DSC613 is a MEMS low power, ultra-small footprint, crystal-less family of clock generators. The DSC613 family is factory-configurable and generates up to three LVCMOS outputs from two PLLs. Each output can be configured to generate frequencies from 2 kHz to 100 MHz.

The DSC613 implements Microchip's proven PureSilicon™ MEMS technology to provide low jitter and high stability across a wide range of supply voltages and temperatures. By eliminating the external quartz crystal, Microchip's crystal-less™ clock generators significantly enhance reliability and accelerate product development.

The DSC613 has one control input that can be configured to function as output enable/disable, standby, sleep, spread spectrum enable, and frequency select. The DSC613 is available in space saving 6-pin, 1.6 mm x 1.2 mm, 2.0 mm x 1.6 mm, and 2.5 mm x 2.0 mm VFLGA plastic packages.

The DSC613 spread spectrum function includes both center and down spreading, and is explained further in the [Spread Spectrum](#) section.

The DSC613 is a highly configurable device and is factory programmed to meet the customer's needs. Microchip's [ClockWorks Configurator](#) must be used to choose the necessary options, create the final part number, data sheet, and order samples.

### Package Type

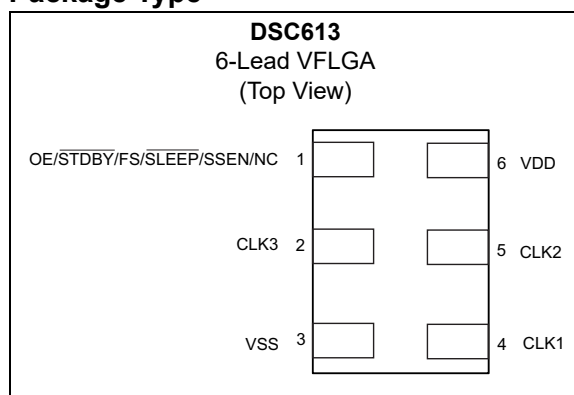

# DSC613

## Functional Block Diagram

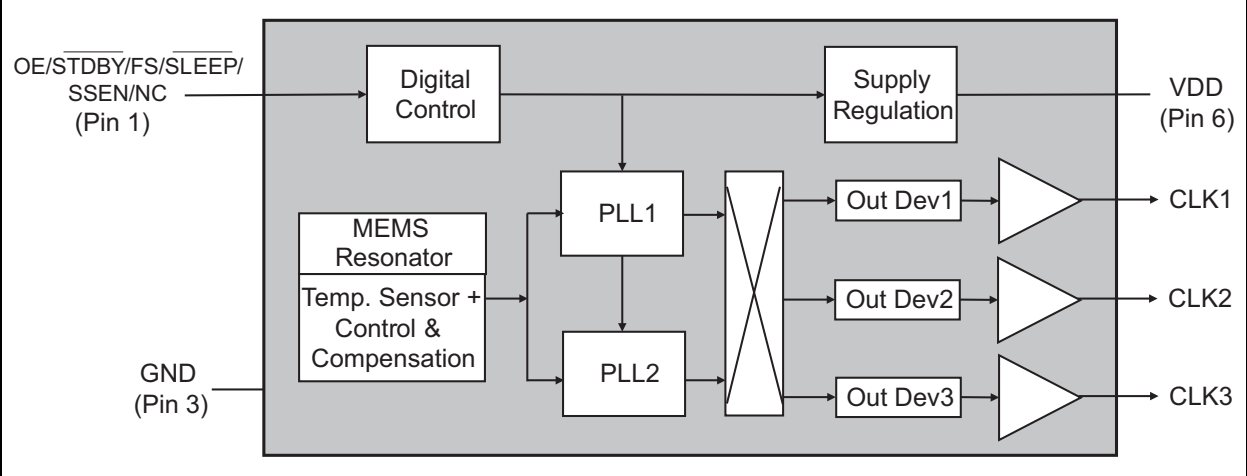

## 1.0 ELECTRICAL CHARACTERISTICS

### Absolute Maximum Ratings †

Supply Voltage .....	-0.3V to +4.0V
Input Voltage .....	-0.3V to $V_{DD} + 0.3V$
ESD Protection (HBM) .....	4 kV
ESD Protection (MM) .....	400V
ESD Protection (CDM) .....	2 kV

† **Notice:** Stresses above those listed under “Absolute Maximum Ratings” may cause permanent damage to the device. This is a stress rating only and functional operation of the device at those or any other conditions above those indicated in the operational sections of this specification is not intended. Exposure to maximum rating conditions for extended periods may affect device reliability.

### ELECTRICAL CHARACTERISTICS

**Electrical Characteristics:**  $V_{DD} = 1.8V \pm 5\%$  to  $3.3V \pm 10\%$ ;  $T_A = -40^\circ C$  to  $+125^\circ C$ , unless noted.

Parameter	Symbol	Min.	Typ.	Max.	Units	Conditions
Supply Voltage	$V_{DD}$	1.71	—	3.63	V	Note 1
Active Supply Current	$I_{DD}$	—	5.2	6.5	mA	$f_{CLK1} = 24$ MHz, $f_{CLK2} = 27$ MHz, $f_{CLK3} = 12$ MHz, $V_{DD} = 1.8V$ , No Load
Active Supply Current (Sleep Mode, 1 PLL Off)	$I_{DDSL}$	—	3	—	mA	CLK2 = SLEEP, $f_{CLK1} = 25$ MHz, $V_{DD} = 1.8V$ , No Load
Active Supply Current (32.768 kHz Output Only)	$I_{DD32k}$	—	1.4	—	mA	$f_{CLK3} = 32.768$ kHz, $V_{DD} = 1.8V$ , No Load
Standby Supply Current, Note 2	$I_{STDBY}$	—	1.0	—	$\mu A$	$V_{DD} = 1.8V/2.5V$
		—	1.5	—		$V_{DD} = 3.3V$
Frequency Stability, Note 3	$\Delta f$	—	—	$\pm 20$	ppm	All temperature ranges
		—	—	$\pm 25$		
		—	—	$\pm 50$		
Aging	$\Delta f$	—	—	$\pm 5$	ppm	1st year @ $+25^\circ C$
		—	—	$\pm 1$		Per year after the first year
Startup Time	$t_{SU}$	—	—	1.5	ms	From 90% $V_{DD}$ to valid clock output, $T = +25^\circ C$
Input Logic Levels, Note 4	$V_{IH}$	$0.7 \times V_{DD}$	—	—	V	Input logic high
	$V_{IL}$	—	—	$0.3 \times V_{DD}$		Input logic low
Output Disable Time	$t_{DA}$	—	—	$200 + 2$ Periods	ns	Note 5
Output Enable Time	$t_{EN}$	—	1.0	—	$\mu s$	Note 6
Enable Pull-Up Resistor	—	—	300	—	k $\Omega$	If configured. Note 7
Output Logic Levels	$V_{OHY}$	$0.8 \times V_{DD}$	—	—	V	$I = 6$ mA (high drive) or $I = 3$ mA (standard drive)
	$V_{OLY}$	—	—	$0.2 \times V_{DD}$		$I = -6$ mA (high drive) or $I = -3$ mA (standard drive)
	$V_{OHX}$	$0.8 \times V_{DD}$	—	—		$I = 1$ mA (low drive)
	$V_{OLX}$	—	—	$0.2 \times V_{DD}$		$I = -1$ mA (low drive)

# DSC613

## ELECTRICAL CHARACTERISTICS (CONTINUED)

Electrical Characteristics:  $V_{DD} = 1.8V \pm 5\%$  to  $3.3V \pm 10\%$ ;  $T_A = -40^\circ C$  to  $+125^\circ C$ , unless noted.

Parameter	Symbol	Min.	Typ.	Max.	Units	Conditions
Output Transition Time, Rise Time/Fall Time	$t_{RY1}/t_{FY1}$	—	1.2	2.0	ns	$V_{DD} = 1.8V$ , Standard drive 20% - 80% $C_L = 10$ pF (CLK1/CLK2)
		—	0.6	1.2		$V_{DD} = 2.5V/3.3V$ , Standard drive 20% - 80% $C_L = 10$ pF (CLK1/CLK2)
	$t_{RY2}/t_{FY2}$	—	1.0	1.5		$V_{DD} = 1.8V$ , High drive 20% - 80% $C_L = 15$ pF (CLK1/CLK2)
		—	0.5	1.0		$V_{DD} = 2.5V/3.3V$ , High drive 20% - 80% $C_L = 15$ pF (CLK1/CLK2)
	$t_{RX}/t_{FX}$	—	2.5	3.5		$V_{DD} = 1.8V$ , Low drive 20% - 80% $C_L = 5$ pF (CLK3)
		—	1.5	2.2		$V_{DD} = 2.5V/3.3V$ , Low drive 20% - 80% $C_L = 5$ pF (CLK3)
Frequency	f0	0.002	—	100	MHz	Note 8
Output Duty Cycle	SYM	45	—	55	%	—
Period Jitter, RMS CLK1/CLK2	$J_{PER}$	—	20	—	ps	$f_{CLK1} = 24$ MHz, $f_{CLK2} = 27$ MHz, $f_{CLK3} = 12$ MHz, $V_{DD} = 1.8V$
		—	14	—		$f_{CLK1} = 24$ MHz, $f_{CLK2} = 27$ MHz, $f_{CLK3} = 12$ MHz, $V_{DD} = 3.3V$
		—	10	—		$f_{CLK1} = 24$ MHz, $f_{CLK2} = 12$ MHz, $f_{CLK3} = 32.768$ kHz, $V_{DD} = 3.3V$
Period Jitter, Peak-to-Peak CLK1/CLK2	$J_{PER}$	—	170	—	ps	$f_{CLK1} = 24$ MHz, $f_{CLK2} = 27$ MHz, $f_{CLK3} = 12$ MHz, $V_{DD} = 1.8V$
		—	140	—		$f_{CLK1} = 24$ MHz, $f_{CLK2} = 27$ MHz, $f_{CLK3} = 12$ MHz, $V_{DD} = 3.3V$
		—	80	—		$f_{CLK1} = 24$ MHz, $f_{CLK2} = 12$ MHz, $f_{CLK3} = 32.768$ kHz, $V_{DD} = 3.3V$
Cycle-to-Cycle Jitter, Peak CLK1/CLK2	$J_{CY-CY}$	—	150	—	ps	$f_{CLK1} = 24$ MHz, $f_{CLK2} = 27$ MHz, $f_{CLK3} = 12$ MHz, $V_{DD} = 1.8V$
		—	120	—		$f_{CLK1} = 24$ MHz, $f_{CLK2} = 27$ MHz, $f_{CLK3} = 12$ MHz, $V_{DD} = 3.3V$
		—	70	—		$f_{CLK1} = 24$ MHz, $f_{CLK2} = 12$ MHz, $f_{CLK3} = 32.768$ kHz, $V_{DD} = 3.3V$

## ELECTRICAL CHARACTERISTICS (CONTINUED)

Electrical Characteristics:  $V_{DD} = 1.8V \pm 5\%$  to  $3.3V \pm 10\%$ ;  $T_A = -40^\circ C$  to  $+125^\circ C$ , unless noted.

Parameter	Symbol	Min.	Typ.	Max.	Units	Conditions
Period Jitter, RMS CLK3	$J_{PER}$	—	40	—	ps	$f_{CLK1} = 24 \text{ MHz}$ , $f_{CLK2} = 27 \text{ MHz}$ , $f_{CLK3} = 12 \text{ MHz}$ , $V_{DD} = 1.8V$
		—	35	—		$f_{CLK1} = 24 \text{ MHz}$ , $f_{CLK2} = 27 \text{ MHz}$ , $f_{CLK3} = 12 \text{ MHz}$ , $V_{DD} = 3.3V$
Period Jitter, Peak-to-Peak CLK3	$J_{PER}$	—	270	—	ps	$f_{CLK1} = 24 \text{ MHz}$ , $f_{CLK2} = 27 \text{ MHz}$ , $f_{CLK3} = 12 \text{ MHz}$ , $V_{DD} = 1.8V$
		—	220	—		$f_{CLK1} = 24 \text{ MHz}$ , $f_{CLK2} = 27 \text{ MHz}$ , $f_{CLK3} = 12 \text{ MHz}$ , $V_{DD} = 3.3V$
Cycle-to-Cycle Jitter, Peak CLK3	$J_{CY-CY}$	—	235	—	ps	$f_{CLK1} = 24 \text{ MHz}$ , $f_{CLK2} = 27 \text{ MHz}$ , $f_{CLK3} = 12 \text{ MHz}$ , $V_{DD} = 1.8V$
		—	190	—		$f_{CLK1} = 24 \text{ MHz}$ , $f_{CLK2} = 27 \text{ MHz}$ , $f_{CLK3} = 12 \text{ MHz}$ , $V_{DD} = 3.3V$

- Note 1:**  $V_{DD}$  pin should be filtered with a 0.1  $\mu F$  capacitor.
- 2:** Excludes pull-up current.
- 3:** Includes frequency variations due to initial tolerance, temperature, and power supply voltage.
- 4:** Input waveform must be monotonic with rise/fall time < 10 ns.
- 5:** Output disable time takes up to two Periods of the output waveform, plus 200 ns.
- 6:** For parts configured with OE, not Standby.
- 7:** Output is enabled if pad is floated or not connected.
- 8:** CLK3 maximum frequency is 80 MHz.

# DSC613

---

---

## TEMPERATURE SPECIFICATIONS (Note 1)

Parameters	Sym.	Min.	Typ.	Max.	Units	Conditions
<b>Temperature Ranges</b>						
Junction Operating Temperature	$T_J$	—	—	+150	°C	—
Storage Temperature Range	$T_S$	-55	—	+150	°C	—
Lead Temperature	—	—	+260	—	°C	Soldering, 40s

**Note 1:** The maximum allowable power dissipation is a function of ambient temperature, the maximum allowable junction temperature and the thermal resistance from junction to air (i.e.,  $T_A$ ,  $T_J$ ,  $\theta_{JA}$ ). Exceeding the maximum allowable power dissipation will cause the device operating junction temperature to exceed the maximum +150°C rating. Sustained junction temperatures above +150°C can impact the device reliability.

## 2.0 PIN DESCRIPTIONS

The DSC613 is a highly configurable device and can be factory programmed in many different ways to meet the customer's needs. Microchip's ClockWorks Configurator <http://clockworks.microchip.com/Timing/> must be used to choose the necessary options, create the final part number, data sheet, and order samples. The descriptions of the pins are listed in [Table 2-1](#).

**TABLE 2-1: DSC613 PIN FUNCTION TABLE**

Pin Number	Pin Name	Description
1	OE	Output Enable: H = Active, L = Disabled (High Impedance).
	$\overline{\text{STDBY}}$	Standby: H = Device is active, L = Device is in standby (Low Power Mode).
	FS	Frequency Select: H = Output Frequency 1, L = Output Frequency 2.
	$\overline{\text{SLEEP}}$	Sleep: H= Output Enabled, L= Output and associated PLL Disabled.
	SSEN	Spread Spectrum: H = Enabled, L = Disabled.
2	CLK3	Factory configurable LVCMOS clock output 3: 2 kHz to 80 MHz, low drive.
3	VSS	Ground.
4	CLK1	Factory configurable LVCMOS clock output 1: 1 MHz to 100 MHz, standard drive or high drive.
5	CLK2	Factory configurable LVCMOS clock output 2: 1 MHz to 100 MHz, standard drive or high drive.
6	VDD	Power Supply: 1.71V to 3.63V.

An explanation of the different options listed in [Table 2-1](#) follows.

### 2.1 Pin 1

This is a control pin and may be configured to fulfill one of six different functions. If not actively driven, a 10 k $\Omega$  pull-up resistor is recommended.

#### 2.1.1 OUTPUT ENABLE (OE)

Pin 1 may be configured as OE. Any combination of outputs may be turned on and off according to the state of this pin (one, two, or all three outputs).

#### 2.1.2 $\overline{\text{STANDBY}}$

Pin 1 may be configured as Standby. When the pin is low, all outputs will be off and the device will enter a low power mode.

#### 2.1.3 $\overline{\text{SLEEP}}$

Pin 1 may be configured as Sleep. When the pin is low, one phase locked loop (PLL) will shut down, enabling power saving. Any outputs driven by that PLL will be turned off.

#### 2.1.4 SPREAD SPECTRUM ENABLE (SSEN)

Pin 1 may be configured as Spread Spectrum Enable. When the pin is high, the associated output will be spread in frequency. When low, no spreading will occur.

#### 2.1.5 FREQUENCY SELECT (FS)

Pin 1 may be configured as FS. Each output may be set to one of two pre-programmed frequencies (six pre-programmed frequencies in all).

#### 2.1.6 NC

Pin 1 may be configured as NC. In this case, the pin is non-functional, and the device is programmed and fixed according to the choices in ClockWorks Configurator.

## 2.2 Pins 2 through 6

Pins 3 and 6 are the supply terminals,  $V_{SS}$  and  $V_{DD}$  respectively. Pins 2, 4, and 5 are the three clock outputs, CLK3, CLK1, and CLK2 respectively. CLK1 and CLK2 outputs are programmable to Standard and High Drive strengths settings. CLK3 is a fixed strength, low drive output. Visit [ClockWorks Configurator](#) to customize your device.

## 3.0 SPREAD SPECTRUM

Spread spectrum is a slow modulation of the clock frequency over time. The PLL inside the MEMS oscillator is modulated with a triangular wave at 33 kHz. With such a slow modulation, the peak spectral energy of both the fundamental and all the harmonics is spread over a wider frequency range. This significantly reduces peak energy density, thus providing an EMI reduction. The triangular wave is chosen because of its flat spectral density.

The DSC613 MEMS oscillator family offers several modulation options: the spreading is either center spread or down spread with respect to the clock frequency. Center spreading ranges from  $\pm 0.25\%$  to  $\pm 2.5\%$ , while down spreading ranges from  $-0.25\%$  to  $-3\%$ .

If the clock frequency is 100 MHz and center spreading with  $\pm 1\%$  is chosen, the output clock will range from 99 MHz to 101 MHz. If down spreading with  $-2\%$  is chosen, the output clock will range from 98 MHz to 100 MHz.

Figure 3-1 and Figure 3-2 show a spectrum example of the DSC613 with a 33.333 MHz clock, modulated with central spread of  $\pm 1\%$ .

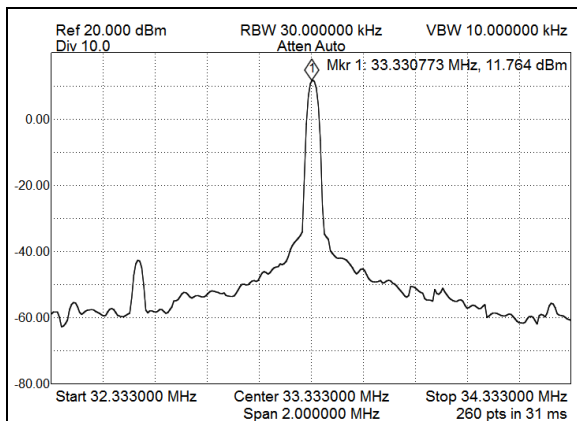

**FIGURE 3-1:** DSC613 Spectrum at 33.333 MHz with Modulation Turned Off.

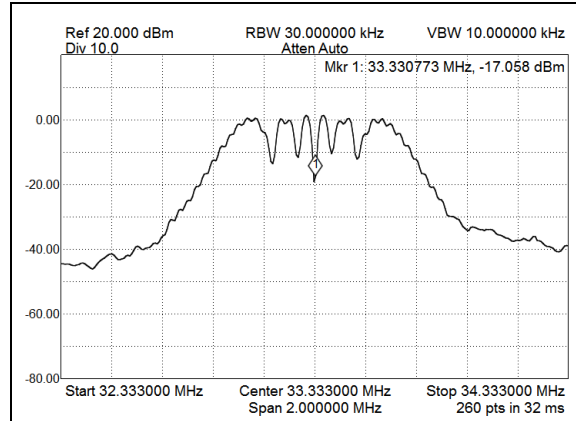

**FIGURE 3-2:** DSC613 Spectrum at 33.333 MHz with Modulation Turned On.

It is noticeable that the spread spectrum provides a reduction of about 10 dB from the peak power. Such a reduction may also be estimated by the following equation:

### EQUATION 3-1:

$$EMI \text{ Reduction} = 10 \times \text{Log}_{10}(|S| \times f_c \div RBW)$$

Where:

- S Peak-to-peak spread percentage (0.01, this example).
- $f_c$  Carrier frequency (33.333 MHz, this example).
- RBW Resolution bandwidth of the spectrum analyzer (30 kHz, this example).

The theoretical calculation for this example provides 10.45 dB, which is consistent with the measurement.

Similarly to the fundamental frequency, all the harmonics are spread and attenuated in similar fashion. Figure 3-3 shows how the DSC613 fundamental at 33.333 MHz and its odd harmonics are attenuated when various types of modulations are selected. For picture clarity, only the center spread options are shown. However, down spread with corresponding percentage provides the same level of harmonic attenuation (e.g. central spread of  $\pm 1\%$  provides the same harmonics attenuation of down spread with  $-2\%$ ).



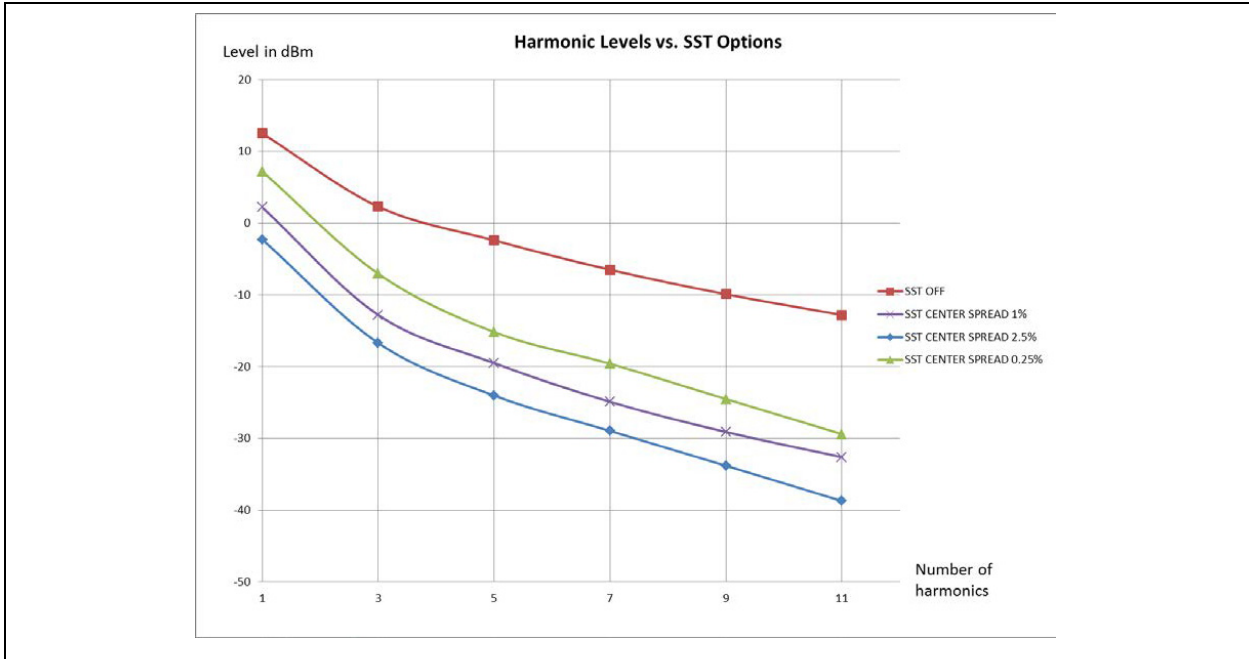
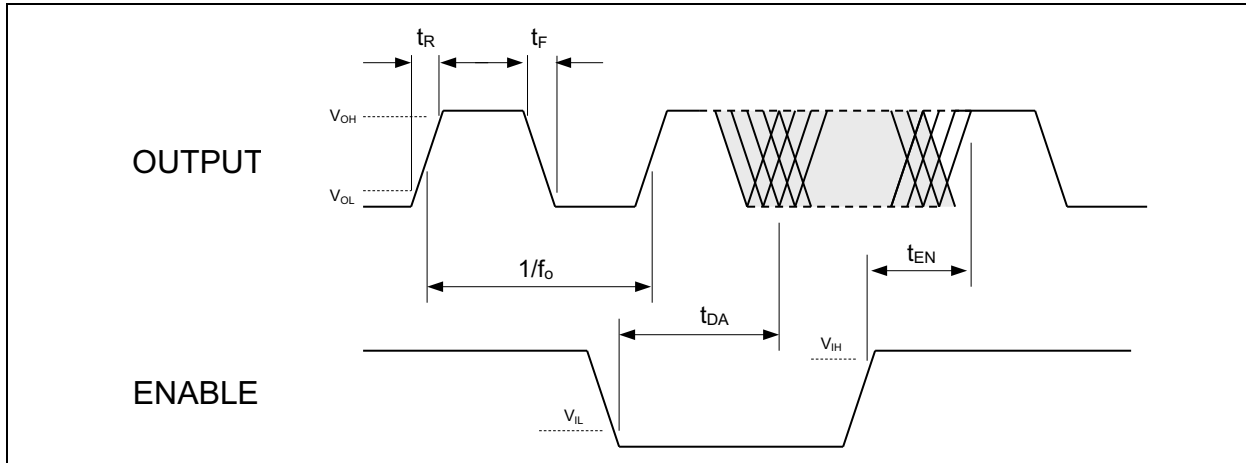

**FIGURE 3-3:** DSC613 Harmonic Levels with Various Spread Spectrum Options.

Visit Microchip's [ClockWorks Configurator](#) to select Spread Spectrum options.

# DSC613

## 4.0 OUTPUT WAVEFORM



**FIGURE 4-1:** DSC613 Output Waveform.

## 5.0 BOARD LAYOUT

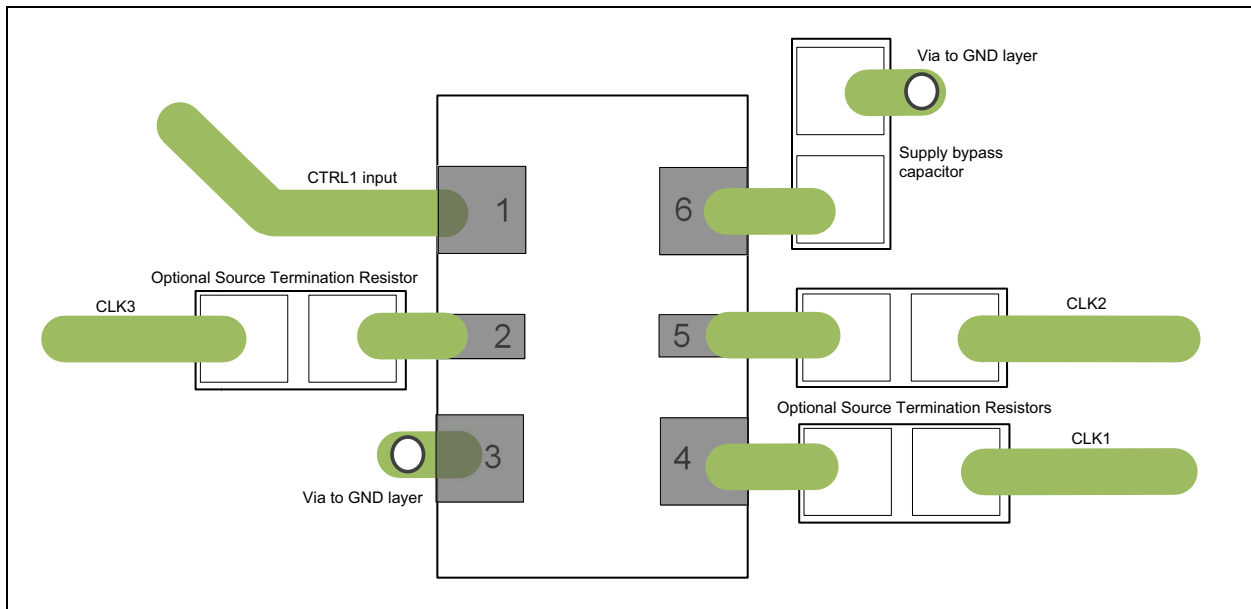

**FIGURE 5-1:** DSC613 Board Layout.

# DSC613

## 6.0 SOLDER REFLOW PROFILE

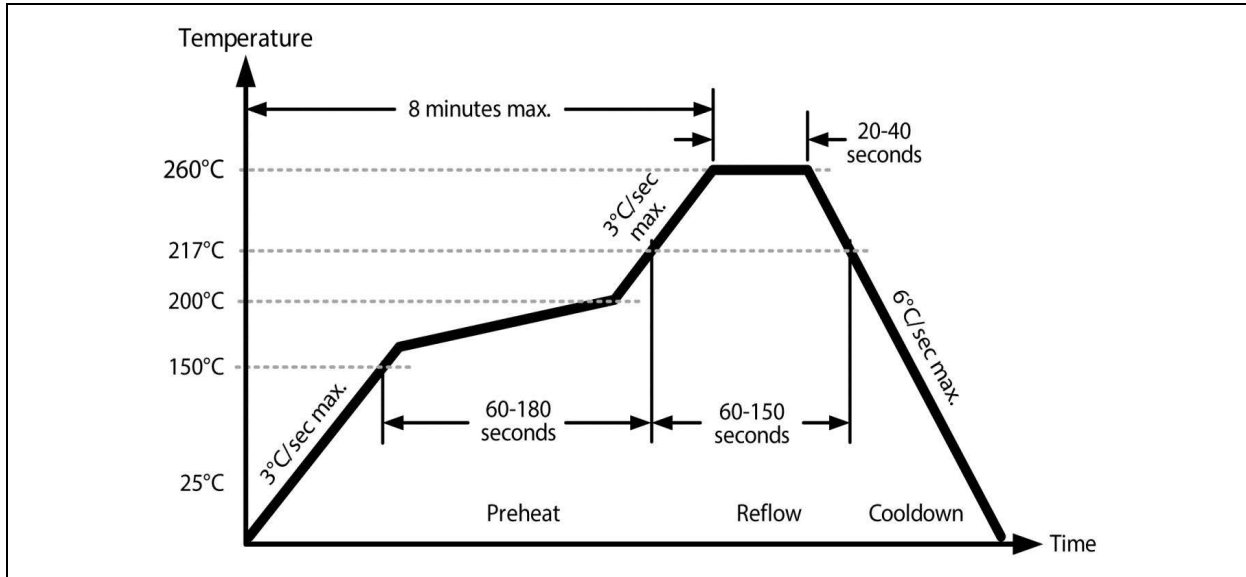

**FIGURE 6-1:** Solder Reflow Profile.

**TABLE 6-1: SOLDER REFLOW**

MSL 1 @ 260°C Refer to JSTD-020C	
Ramp-Up Rate (200°C to Peak Temp.)	3°C/sec. max.
Preheat Time 150°C to 200°C	60 to 180 sec.
Time Maintained above 217°C	60 to 150 sec.
Peak Temperature	255°C to 260°C
Time within 5°C of Actual Peak	20 to 40 sec.
Ramp-Down Rate	6°C/sec. max.
Time 25°C to Peak Temperature	8 minutes max.

## 7.0 PACKAGING INFORMATION

### 7.1 Package Marking Information

6-Lead VFLGA\*  
(2.5mm x 2.0mm)

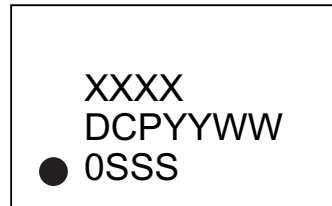

Example



6-Lead VFLGA\*  
(1.2mm x 1.6mm)  
(1.6mm x 2.0mm)



Example

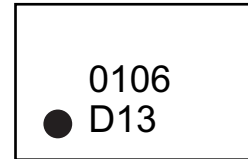

<b>Legend:</b>	XX...X	Product code or customer-specific information
	Y	Year code (last digit of calendar year)
	YY	Year code (last 2 digits of calendar year)
	WW	Week code (week of January 1 is week '01')
	SSS	Alphanumeric traceability code
	(e3)	Pb-free JEDEC® designator for Matte Tin (Sn)
	*	This package is Pb-free. The Pb-free JEDEC designator ((e3)) can be found on the outer packaging for this package.
	●, ▲, ▼	Pin one index is identified by a dot, delta up, or delta down (triangle mark).

**Note:** In the event the full Microchip part number cannot be marked on one line, it will be carried over to the next line, thus limiting the number of available characters for customer-specific information. Package may or may not include the corporate logo.

Underbar ( ) and/or Overbar ( ) symbol may not be to scale.

# DSC613

## 6-Lead Very Thin Fine Pitch Land Grid Array (AVA) - 1.6x1.2 mm Body [VFLGA]

**Note:** For the most current package drawings, please see the Microchip Packaging Specification located at <http://www.microchip.com/packaging>

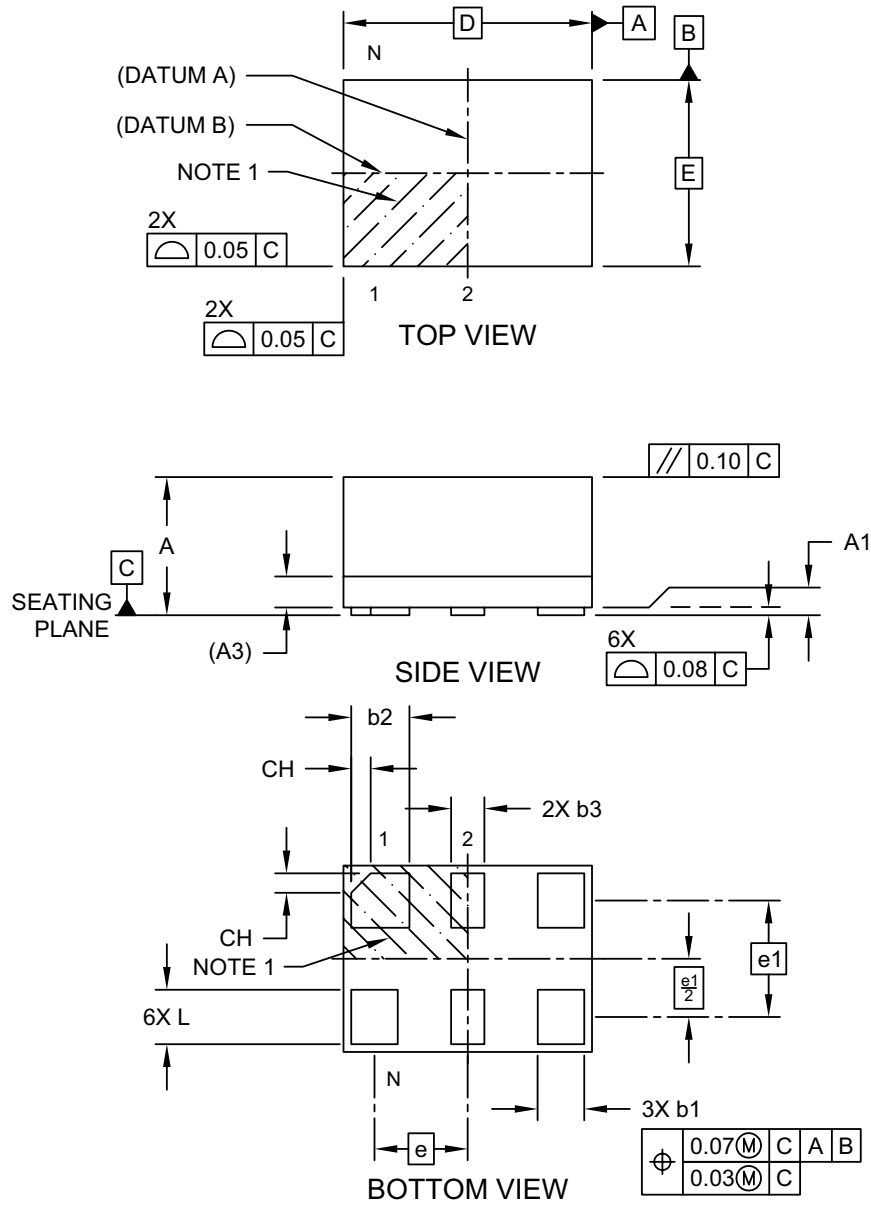

Microchip Technology Drawing C04-1203A Sheet 1 of 2

## 6-Lead Very Thin Fine Pitch Land Grid Array (AVA) - 1.6x1.2 mm Body [VFLGA]

**Note:** For the most current package drawings, please see the Microchip Packaging Specification located at <http://www.microchip.com/packaging>

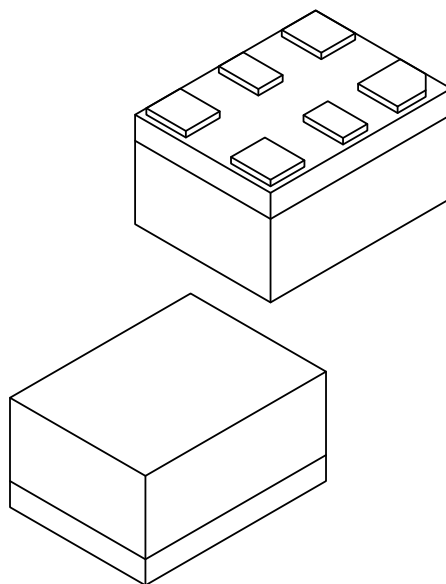

Dimension Limits	Units	MILLIMETERS		
		MIN	NOM	MAX
Number of Terminals	N	6		
Terminal Pitch	e	0.60 BSC		
Terminal Pitch	e1	0.75 BSC		
Overall Height	A	0.79	0.84	0.89
Standoff	A1	0.00	0.02	0.05
Substrate Thickness (with Terminals)	A3	0.20 REF		
Overall Length	D	1.60 BSC		
Overall Width	E	1.20 BSC		
Terminal Width	b1	0.25	0.30	0.35
Terminal Width	b2	0.325	0.375	0.425
Terminal Width	b3	0.20	0.25	0.30
Terminal Length	L	0.30	0.35	0.40
Terminal 1 Index Chamfer	CH	-	0.125	-

**Notes:**

- Pin 1 visual index feature may vary, but must be located within the hatched area.
- Package is saw singulated
- Dimensioning and tolerancing per ASME Y14.5M

BSC: Basic Dimension. Theoretically exact value shown without tolerances.

REF: Reference Dimension, usually without tolerance, for information purposes only.

Microchip Technology Drawing C04-1203A Sheet 2 of 2

## 6-Lead Very Thin Fine Pitch Land Grid Array (AVA) - 1.6x1.2 mm Body [VFLGA]

**Note:** For the most current package drawings, please see the Microchip Packaging Specification located at <http://www.microchip.com/packaging>

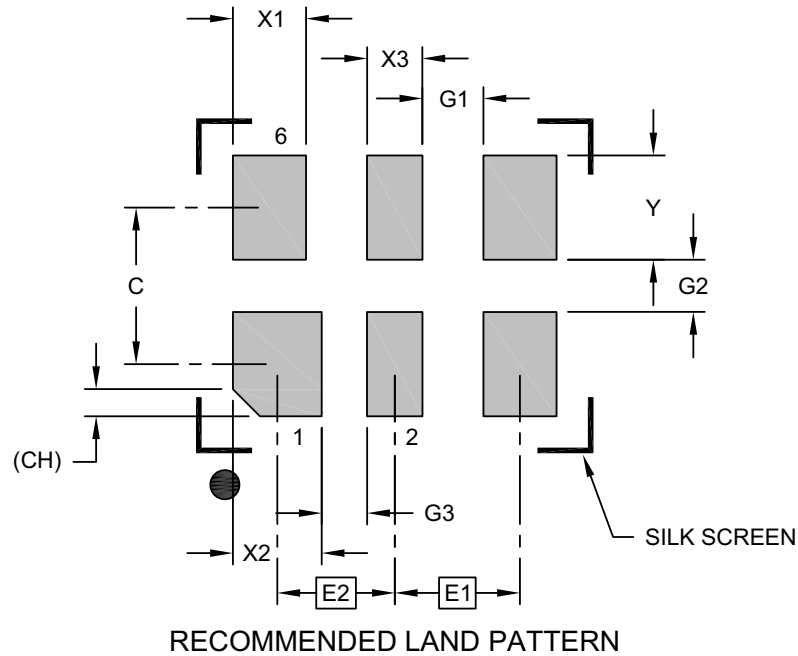

Dimension Limits	Units	MILLIMETERS		
		MIN	NOM	MAX
Contact Pitch (X3)	E1	0.60 BSC		
Contact Pitch	E2	0.56 BSC		
Contact Spacing	C	0.75		
Contact Width (X3)	X1			0.35
Contact Width	X2			0.43
Contact Width (X2)	X3			0.27
Contact Pad Length (X6)	Y			0.50
Space Between Contacts (X4)	G1	0.29		
Space Between Contacts (X3)	G2	0.25		
Space Between Contacts	G3	0.22		
Contact 1 Index Chamfer	CH	0.13 X 45° REF		

**Notes:**

1. Dimensioning and tolerancing per ASME Y14.5M

BSC: Basic Dimension. Theoretically exact value shown without tolerances.

Microchip Technology Drawing C04-3203A



## 6-Lead Very Thin Fine Pitch Land Grid Array (ATA) - 2.0x1.6 mm Body [VFLGA]

**Note:** For the most current package drawings, please see the Microchip Packaging Specification located at <http://www.microchip.com/packaging>

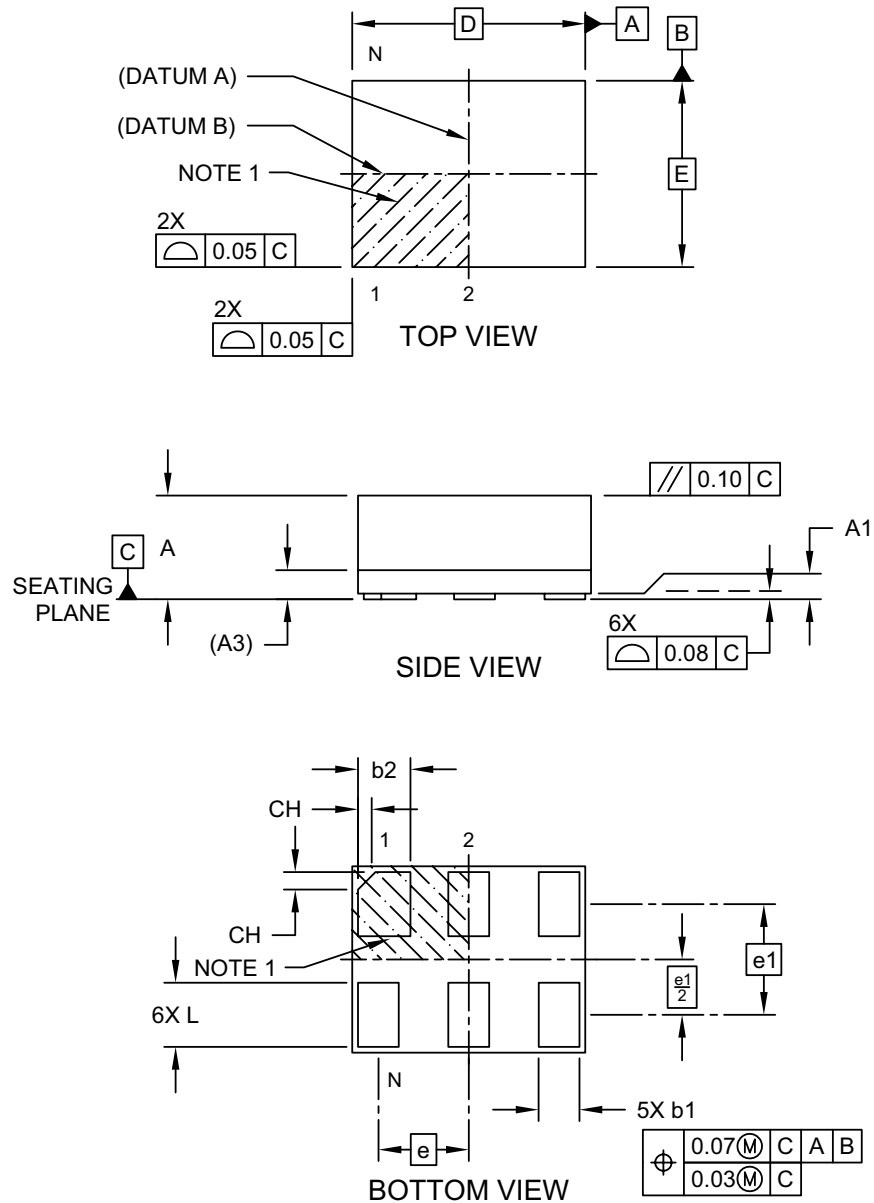

Microchip Technology Drawing C04-1201A Sheet 1 of 2

# DSC613

## 6-Lead Very Thin Fine Pitch Land Grid Array (ATA) - 2.0x1.6 mm Body [VFLGA]

**Note:** For the most current package drawings, please see the Microchip Packaging Specification located at <http://www.microchip.com/packaging>

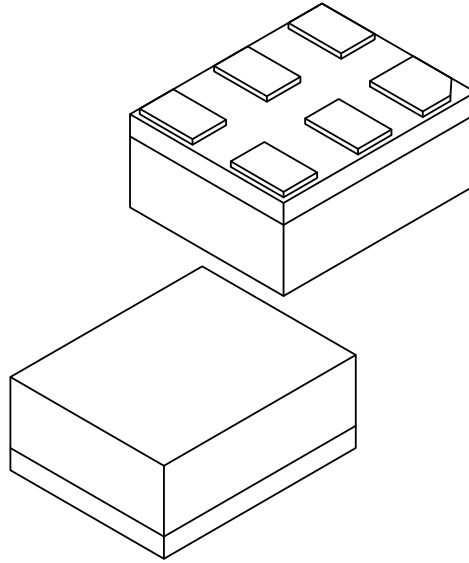

Units		MILLIMETERS		
Dimension Limits		MIN	NOM	MAX
Number of Terminals	N	6		
Terminal Pitch	e	0.775 BSC		
Terminal Pitch	e1	0.95 BSC		
Overall Height	A	0.79	0.84	0.89
Standoff	A1	0.00	0.02	0.05
Substrate Thickness (with Terminals)	A3	0.20 REF		
Overall Length	D	2.00 BSC		
Overall Width	E	1.60 BSC		
Terminal Width	b1	0.30	0.35	0.40
Terminal Width	b2	0.40	0.45	0.50
Terminal Length	L	0.50	0.55	0.60
Terminal 1 Index Chamfer	CH	-	0.15	-

**Notes:**

1. Pin 1 visual index feature may vary, but must be located within the hatched area.
2. Package is saw singulated
3. Dimensioning and tolerancing per ASME Y14.5M

BSC: Basic Dimension. Theoretically exact value shown without tolerances.

REF: Reference Dimension, usually without tolerance, for information purposes only.

Microchip Technology Drawing C04-1201A Sheet 2 of 2

## 6-Lead Very Thin Fine Pitch Land Grid Array (ATA) - 2.0x1.6 mm Body [VFLGA]

**Note:** For the most current package drawings, please see the Microchip Packaging Specification located at <http://www.microchip.com/packaging>

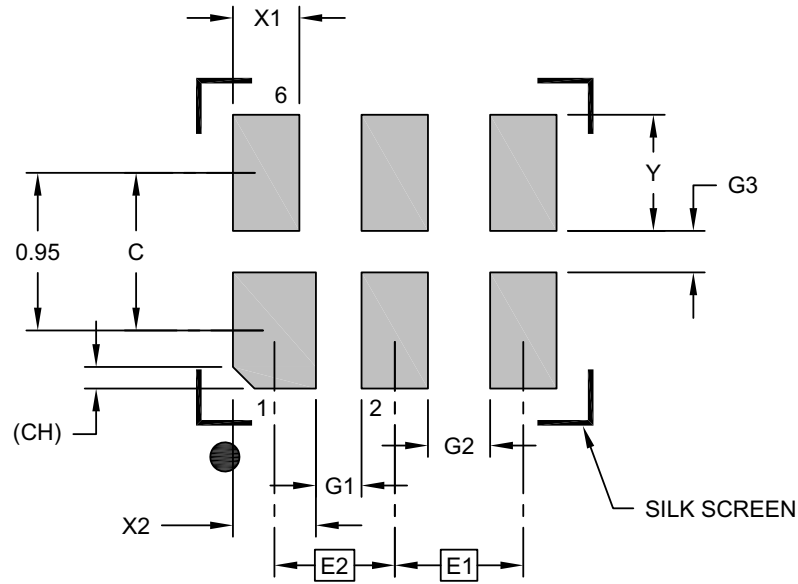

RECOMMENDED LAND PATTERN

Dimension Limits	Units	MILLIMETERS		
		MIN	NOM	MAX
Contact Pitch	E1		0.78 BSC	
Contact Pitch	E2		0.73 BSC	
Contact Spacing	C		0.95	
Contact Width (X4)	X1			0.40
Contact Width (X2)	X2			0.45
Contact Pad Length (X6)	Y			0.70
Space Between Contacts (X4)	G1	0.28		
Space Between Contacts (X3)	G2	0.38		
Space Between Contacts (X3)	G3	0.25		
Contact 1 Index Chamfer	CH	0.13 X 45° REF		

**Notes:**

1. Dimensioning and tolerancing per ASME Y14.5M  
BSC: Basic Dimension. Theoretically exact value shown without tolerances.

Microchip Technology Drawing C04-3201A

# DSC613

## 6-Lead Very Thin Fine Pitch Land Grid Array (AWA) - 2.5x2.0 mm Body [VFLGA]

**Note:** For the most current package drawings, please see the Microchip Packaging Specification located at <http://www.microchip.com/packaging>

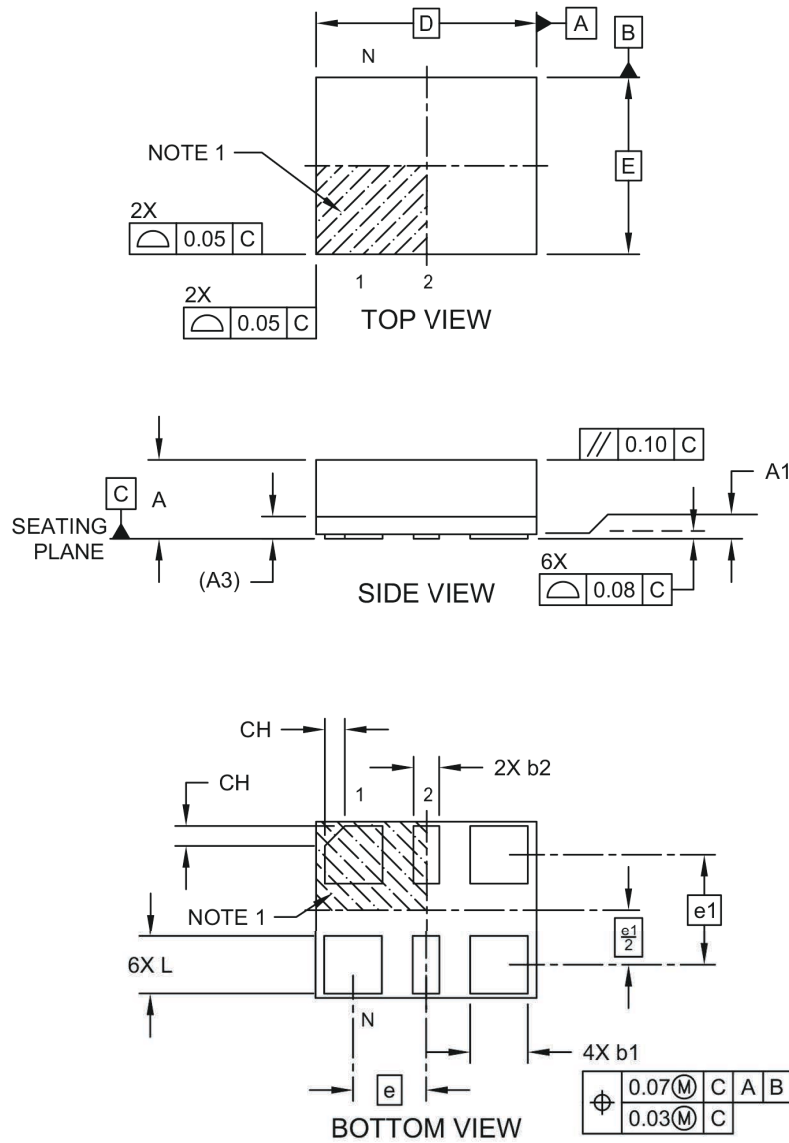

Microchip Technology Drawing C04-01204 Rev C Sheet 1 of 2

## 6-Lead Very Thin Fine Pitch Land Grid Array (AWA) - 2.5x2.0 mm Body [VFLGA]

**Note:** For the most current package drawings, please see the Microchip Packaging Specification located at <http://www.microchip.com/packaging>

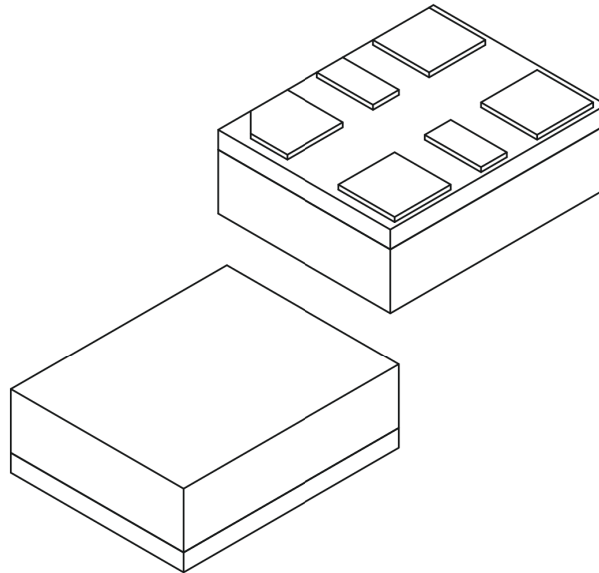

Dimension Limits	Units	MILLIMETERS		
		MIN	NOM	MAX
Number of Terminals	N	6		
Terminal Pitch	e	0.825 BSC		
Terminal Pitch	e1	1.25 BSC		
Overall Height	A	0.79	0.84	0.89
Standoff	A1	0.00	0.02	0.05
Substrate Thickness (with Terminals)	A3	0.20 REF		
Overall Length	D	2.50 BSC		
Overall Width	E	2.00 BSC		
Terminal Width	b1	0.60	0.65	0.70
Terminal Width	b2	0.25	0.30	0.35
Terminal Length	L	0.60	0.65	0.70
Terminal 1 Index Chamfer	CH	-	0.225	-

**Notes:**

- Pin 1 visual index feature may vary, but must be located within the hatched area.
- Dimensioning and tolerancing per ASME Y14.5M  
 BSC: Basic Dimension. Theoretically exact value shown without tolerances.  
 REF: Reference Dimension, usually without tolerance, for information purposes only.

Microchip Technology Drawing C04-01204 Rev C Sheet 2 of 2

## 6-Lead Very Thin Fine Pitch Land Grid Array (AWA) - 2.5x2.0 mm Body [VFLGA]

**Note:** For the most current package drawings, please see the Microchip Packaging Specification located at <http://www.microchip.com/packaging>

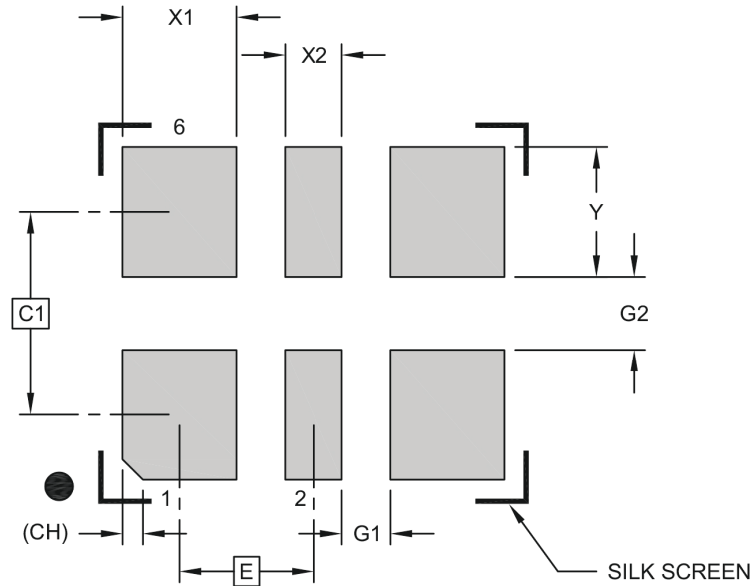

### RECOMMENDED LAND PATTERN

Dimension Limits	Units	MILLIMETERS		
		MIN	NOM	MAX
Contact Pitch	E	0.825 BSC		
Contact Spacing	C	1.25 BSC		
Contact Width (X4)	X1			0.70
Contact Width (X2)	X2			0.35
Contact Pad Length (X6)	Y			0.80
Space Between Contacts (X4)	G1	0.30		
Space Between Contacts (X3)	G2	0.45		
Contact 1 Index Chamfer	CH	0.13 X 45° REF		

**Notes:**

1. Dimensioning and tolerancing per ASME Y14.5M

BSC: Basic Dimension. Theoretically exact value shown without tolerances.

Microchip Technology Drawing C04-03204 Rev C

## APPENDIX A: REVISION HISTORY

### Revision A (October 2018)

- Initial release of DSC613 as Microchip data sheet DS20006024A.

### Revision B (August 2022)

- Updated the AWA package drawings.
- Updated the [Functional Block Diagram](#).

# DSC613

---

---

NOTES:



## PRODUCT IDENTIFICATION SYSTEM

To order or obtain information, e.g., on pricing or delivery, contact your local Microchip representative or sales office.

<u>PART NO.</u>	X	X	X	X	-XXXX	X
Device	Package	Temperature	Frequency Stability	Code Rev.	Configuration #	Special Processing
<b>Device:</b> DSC613: Three-Output Low Power MEMS Clock Generator  <b>Package:</b> R = 6-Lead 2.5 mm x 2.0 mm VFLGA N = 6-Lead 2.0 mm x 1.6 mm VFLGA P = 6-Lead 1.6 mm x 1.2 mm VFLGA  <b>Temperature:</b> A = -40°C to +125°C (Automotive) L = -40°C to +105°C (Commercial) I = -40°C to +85°C (Industrial) E = -20°C to +70°C (Extended Industrial)  <b>Frequency Stability:</b> 1 = ±50 ppm 2 = ±25 ppm 3 = ±20 ppm  <b>Code Revision:</b> A = 1st Revision  <b>Configuration Number:</b> User-Defined in the ClockWorks Configurator  <b>Special Processing:</b> <blank>= 140/Tube (R Package Option) <blank>= 100/Bag (N & P Package Options) T = 1,000/Reel B = 3,000/Reel	<b>Examples:</b> a) DSC613RE1A-0024T: Three-Output Low Power MEMS Clock Generator, 6-Lead 2.5 mm x 2.0 mm VFLGA, -20°C to +70°C, ±50 ppm, 1st Revision, 1,000/Reel b) DSC613NL2A-2885: Three-Output Low Power MEMS Clock Generator, 6-Lead 2.0 mm x 1.6 mm VFLGA, -40°C to +105°C, ±25 ppm, 1st Revision, 100/Bag c) DSC613PA3A-8751B: Three-Output Low Power MEMS Clock Generator, 6-Lead 1.6 mm x 1.2 mm VFLGA, -40°C to +125°C, ±20 ppm, 1st Revision, 3,000/Reel  <b>Note 1:</b> Tape and Reel identifier only appears in the catalog part number description. This identifier is used for ordering purposes and is not printed on the device package. Check with your Microchip Sales Office for package availability with the Tape and Reel option.					

The DSC613 is a highly configurable device and is factory programmed to meet the customer's needs. Microchip's [ClockWorks Configurator](#) must be used to choose the necessary options, create the final part number, data sheet, and order samples.

# DSC613

---

---

NOTES:

---

---

**Note the following details of the code protection feature on Microchip products:**

- Microchip products meet the specifications contained in their particular Microchip Data Sheet.
- Microchip believes that its family of products is secure when used in the intended manner, within operating specifications, and under normal conditions.
- Microchip values and aggressively protects its intellectual property rights. Attempts to breach the code protection features of Microchip product is strictly prohibited and may violate the Digital Millennium Copyright Act.
- Neither Microchip nor any other semiconductor manufacturer can guarantee the security of its code. Code protection does not mean that we are guaranteeing the product is "unbreakable" Code protection is constantly evolving. Microchip is committed to continuously improving the code protection features of our products.

---

This publication and the information herein may be used only with Microchip products, including to design, test, and integrate Microchip products with your application. Use of this information in any other manner violates these terms. Information regarding device applications is provided only for your convenience and may be superseded by updates. It is your responsibility to ensure that your application meets with your specifications. Contact your local Microchip sales office for additional support or, obtain additional support at <https://www.microchip.com/en-us/support/design-help/client-support-services>.

THIS INFORMATION IS PROVIDED BY MICROCHIP "AS IS". MICROCHIP MAKES NO REPRESENTATIONS OR WARRANTIES OF ANY KIND WHETHER EXPRESS OR IMPLIED, WRITTEN OR ORAL, STATUTORY OR OTHERWISE, RELATED TO THE INFORMATION INCLUDING BUT NOT LIMITED TO ANY IMPLIED WARRANTIES OF NON-INFRINGEMENT, MERCHANTABILITY, AND FITNESS FOR A PARTICULAR PURPOSE, OR WARRANTIES RELATED TO ITS CONDITION, QUALITY, OR PERFORMANCE.

IN NO EVENT WILL MICROCHIP BE LIABLE FOR ANY INDIRECT, SPECIAL, PUNITIVE, INCIDENTAL, OR CONSEQUENTIAL LOSS, DAMAGE, COST, OR EXPENSE OF ANY KIND WHATSOEVER RELATED TO THE INFORMATION OR ITS USE, HOWEVER CAUSED, EVEN IF MICROCHIP HAS BEEN ADVISED OF THE POSSIBILITY OR THE DAMAGES ARE FORESEEABLE. TO THE FULLEST EXTENT ALLOWED BY LAW, MICROCHIP'S TOTAL LIABILITY ON ALL CLAIMS IN ANY WAY RELATED TO THE INFORMATION OR ITS USE WILL NOT EXCEED THE AMOUNT OF FEES, IF ANY, THAT YOU HAVE PAID DIRECTLY TO MICROCHIP FOR THE INFORMATION.

Use of Microchip devices in life support and/or safety applications is entirely at the buyer's risk, and the buyer agrees to defend, indemnify and hold harmless Microchip from any and all damages, claims, suits, or expenses resulting from such use. No licenses are conveyed, implicitly or otherwise, under any Microchip intellectual property rights unless otherwise stated.

For information regarding Microchip's Quality Management Systems, please visit [www.microchip.com/quality](http://www.microchip.com/quality).

**Trademarks**

The Microchip name and logo, the Microchip logo, Adaptec, AVR, AVR logo, AVR Freaks, BesTime, BitCloud, CryptoMemory, CryptoRF, dsPIC, flexPWR, HELDO, IGL00, JukeBlox, KeeLoq, Klear, LANCheck, LinkMD, maXStylus, maXTouch, MediaLB, megaAVR, Microsemi, Microsemi logo, MOST, MOST logo, MPLAB, OptoLyzer, PIC, picoPower, PICSTART, PIC32 logo, PolarFire, Prochip Designer, QTouch, SAM-BA, SenGenuity, SpyNIC, SST, SST Logo, SuperFlash, Symmetricom, SyncServer, Tachyon, TimeSource, tinyAVR, UNI/O, Vectron, and XMEGA are registered trademarks of Microchip Technology Incorporated in the U.S.A. and other countries.

AgileSwitch, APT, ClockWorks, The Embedded Control Solutions Company, EtherSynch, Flashtec, Hyper Speed Control, HyperLight Load, Libero, motorBench, mTouch, Powermite 3, Precision Edge, ProASIC, ProASIC Plus, ProASIC Plus logo, Quiet-Wire, SmartFusion, SyncWorld, Temux, TimeCesium, TimeHub, TimePictra, TimeProvider, TrueTime, and ZL are registered trademarks of Microchip Technology Incorporated in the U.S.A.

Adjacent Key Suppression, AKS, Analog-for-the-Digital Age, Any Capacitor, AnyIn, AnyOut, Augmented Switching, BlueSky, BodyCom, Clockstudio, CodeGuard, CryptoAuthentication, CryptoAutomotive, CryptoCompanion, CryptoController, dsPICDEM, dsPICDEM.net, Dynamic Average Matching, DAM, ECAN, Espresso T1S, EtherGREEN, GridTime, IdealBridge, In-Circuit Serial Programming, ICSP, INICnet, Intelligent Paralleling, IntelliMOS, Inter-Chip Connectivity, JitterBlocker, Knob-on-Display, KoD, maxCrypto, maxView, memBrain, Mindi, MiWi, MPASM, MPF, MPLAB Certified logo, MPLIB, MPLINK, MultiTRAK, NetDetach, Omniscient Code Generation, PICDEM, PICDEM.net, PICkit, PICtail, PowerSmart, PureSilicon, QMatrix, REAL ICE, Ripple Blocker, RTAX, RTG4, SAM-ICE, Serial Quad I/O, simpleMAP, SimpliPHY, SmartBuffer, SmartHLS, SMART-I.S., storClad, SQI, SuperSwitcher, SuperSwitcher II, Switchtec, SynchroPHY, Total Endurance, Trusted Time, TSHARC, USBCheck, VariSense, VectorBlox, VeriPHY, ViewSpan, WiperLock, XpressConnect, and ZENA are trademarks of Microchip Technology Incorporated in the U.S.A. and other countries.

SQTP is a service mark of Microchip Technology Incorporated in the U.S.A.

The Adaptec logo, Frequency on Demand, Silicon Storage Technology, and Symmcom are registered trademarks of Microchip Technology Inc. in other countries.

GestIC is a registered trademark of Microchip Technology Germany II GmbH & Co. KG, a subsidiary of Microchip Technology Inc., in other countries.

All other trademarks mentioned herein are property of their respective companies.

© 2018-2022, Microchip Technology Incorporated and its subsidiaries.

All Rights Reserved.

ISBN: 978-1-6683-1096-0



# MICROCHIP

## Worldwide Sales and Service

### AMERICAS

#### Corporate Office

2355 West Chandler Blvd.

Chandler, AZ 85224-6199

Tel: 480-792-7200

Fax: 480-792-7277

Technical Support:

<http://www.microchip.com/support>

Web Address:

[www.microchip.com](http://www.microchip.com)

#### Atlanta

Duluth, GA

Tel: 678-957-9614

Fax: 678-957-1455

#### Austin, TX

Tel: 512-257-3370

#### Boston

Westborough, MA

Tel: 774-760-0087

Fax: 774-760-0088

#### Chicago

Itasca, IL

Tel: 630-285-0071

Fax: 630-285-0075

#### Dallas

Addison, TX

Tel: 972-818-7423

Fax: 972-818-2924

#### Detroit

Novi, MI

Tel: 248-848-4000

#### Houston, TX

Tel: 281-894-5983

#### Indianapolis

Noblesville, IN

Tel: 317-773-8323

Fax: 317-773-5453

Tel: 317-536-2380

#### Los Angeles

Mission Viejo, CA

Tel: 949-462-9523

Fax: 949-462-9608

Tel: 951-273-7800

#### Raleigh, NC

Tel: 919-844-7510

#### New York, NY

Tel: 631-435-6000

#### San Jose, CA

Tel: 408-735-9110

Tel: 408-436-4270

#### Canada - Toronto

Tel: 905-695-1980

Fax: 905-695-2078

### ASIA/PACIFIC

#### Australia - Sydney

Tel: 61-2-9868-6733

#### China - Beijing

Tel: 86-10-8569-7000

#### China - Chengdu

Tel: 86-28-8665-5511

#### China - Chongqing

Tel: 86-23-8980-9588

#### China - Dongguan

Tel: 86-769-8702-9880

#### China - Guangzhou

Tel: 86-20-8755-8029

#### China - Hangzhou

Tel: 86-571-8792-8115

#### China - Hong Kong SAR

Tel: 852-2943-5100

#### China - Nanjing

Tel: 86-25-8473-2460

#### China - Qingdao

Tel: 86-532-8502-7355

#### China - Shanghai

Tel: 86-21-3326-8000

#### China - Shenyang

Tel: 86-24-2334-2829

#### China - Shenzhen

Tel: 86-755-8864-2200

#### China - Suzhou

Tel: 86-186-6233-1526

#### China - Wuhan

Tel: 86-27-5980-5300

#### China - Xian

Tel: 86-29-8833-7252

#### China - Xiamen

Tel: 86-592-2388138

#### China - Zhuhai

Tel: 86-756-3210040

### ASIA/PACIFIC

#### India - Bangalore

Tel: 91-80-3090-4444

#### India - New Delhi

Tel: 91-11-4160-8631

#### India - Pune

Tel: 91-20-4121-0141

#### Japan - Osaka

Tel: 81-6-6152-7160

#### Japan - Tokyo

Tel: 81-3-6880-3770

#### Korea - Daegu

Tel: 82-53-744-4301

#### Korea - Seoul

Tel: 82-2-554-7200

#### Malaysia - Kuala Lumpur

Tel: 60-3-7651-7906

#### Malaysia - Penang

Tel: 60-4-227-8870

#### Philippines - Manila

Tel: 63-2-634-9065

#### Singapore

Tel: 65-6334-8870

#### Taiwan - Hsin Chu

Tel: 886-3-577-8366

#### Taiwan - Kaohsiung

Tel: 886-7-213-7830

#### Taiwan - Taipei

Tel: 886-2-2508-8600

#### Thailand - Bangkok

Tel: 66-2-694-1351

#### Vietnam - Ho Chi Minh

Tel: 84-28-5448-2100

### EUROPE

#### Austria - Wels

Tel: 43-7242-2244-39

Fax: 43-7242-2244-393

#### Denmark - Copenhagen

Tel: 45-4485-5910

Fax: 45-4485-2829

#### Finland - Espoo

Tel: 358-9-4520-820

#### France - Paris

Tel: 33-1-69-53-63-20

Fax: 33-1-69-30-90-79

#### Germany - Garching

Tel: 49-8931-9700

#### Germany - Haan

Tel: 49-2129-3766400

#### Germany - Heilbronn

Tel: 49-7131-72400

#### Germany - Karlsruhe

Tel: 49-721-625370

#### Germany - Munich

Tel: 49-89-627-144-0

Fax: 49-89-627-144-44

#### Germany - Rosenheim

Tel: 49-8031-354-560

#### Israel - Ra'anana

Tel: 972-9-744-7705

#### Italy - Milan

Tel: 39-0331-742611

Fax: 39-0331-466781

#### Italy - Padova

Tel: 39-049-7625286

#### Netherlands - Drunen

Tel: 31-416-690399

Fax: 31-416-690340

#### Norway - Trondheim

Tel: 47-7288-4388

#### Poland - Warsaw

Tel: 48-22-3325737

#### Romania - Bucharest

Tel: 40-21-407-87-50

#### Spain - Madrid

Tel: 34-91-708-08-90

Fax: 34-91-708-08-91

#### Sweden - Gothenberg

Tel: 46-31-704-60-40

#### Sweden - Stockholm

Tel: 46-8-5090-4654

#### UK - Wokingham

Tel: 44-118-921-5800

Fax: 44-118-921-5820