

THIS DRAWING IS UNPUBLISHED. RELEASED FOR PUBLICATION
 © COPYRIGHT - By - TE CONNECTIVITY ALL RIGHTS RESERVED.

LOC	DIST	REVISIONS					
CM	54	P	LTR	DESCRIPTION	DATE	DWN	APVD
		U1		ECO-14-012257	30OCT2014	KR	OC

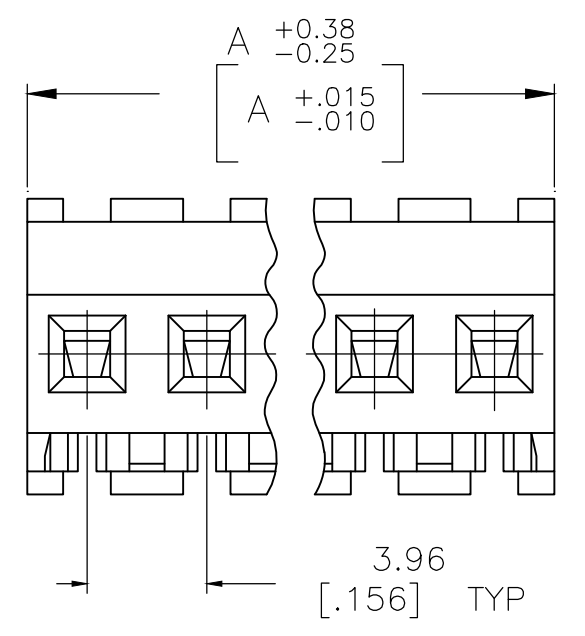
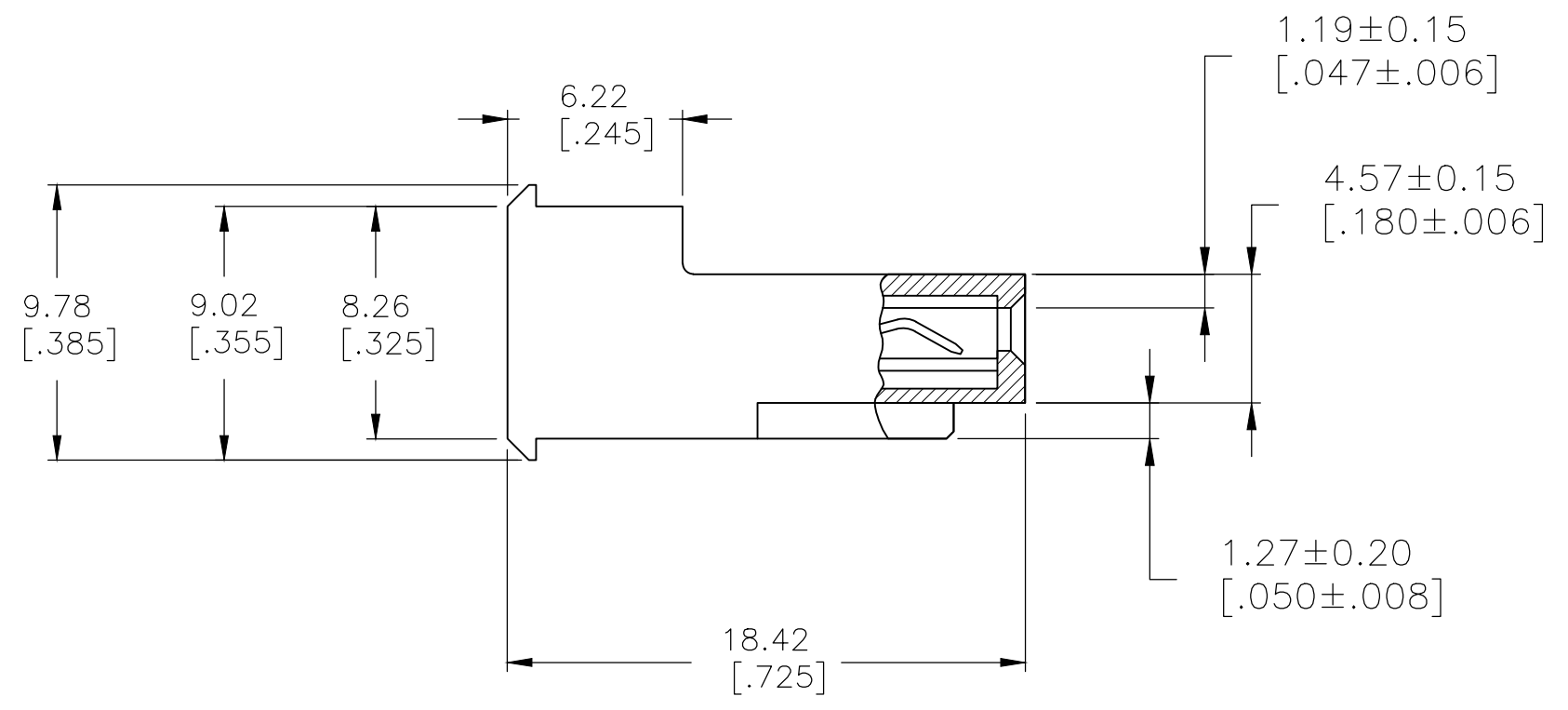
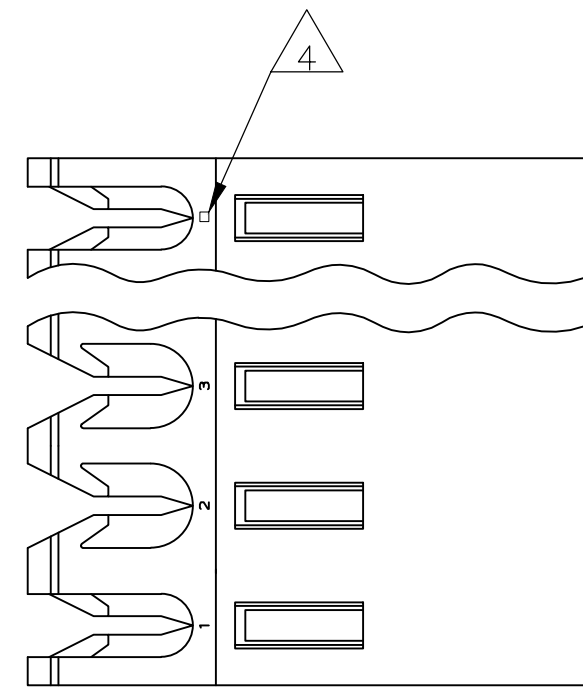

DIM A	NO OF CIRCUITS	PART NO
95.10 [3.744]	24	5-640604-4
91.14 [3.588]	23	5-640604-3
87.17 [3.432]	22	5-640604-2
83.21 [3.276]	21	5-640604-1
79.25 [3.120]	20	5-640604-0
75.29 [2.964]	19	4-640604-9
71.32 [2.808]	18	4-640604-8
67.36 [2.652]	17	4-640604-7
63.40 [2.496]	16	4-640604-6
59.44 [2.340]	15	4-640604-5
55.47 [2.184]	14	4-640604-4
51.51 [2.028]	13	4-640604-3
47.55 [1.872]	12	4-640604-2
43.59 [1.716]	11	4-640604-1
39.62 [1.560]	10	4-640604-0
35.66 [1.404]	9	3-640604-9
31.70 [1.248]	8	3-640604-8
27.74 [1.092]	7	3-640604-7
23.77 [.936]	6	3-640604-6
19.81 [.780]	5	3-640604-5
15.85 [.624]	4	3-640604-4
11.89 [.468]	3	3-640604-3
7.92 [.312]	2	3-640604-2
95.10 [3.744]	24	2-640604-4
91.14 [3.588]	23	2-640604-3
87.17 [3.432]	22	2-640604-2
83.21 [3.276]	21	2-640604-1
79.25 [3.120]	20	2-640604-0
75.29 [2.964]	19	1-640604-9
71.32 [2.808]	18	1-640604-8
67.36 [2.652]	17	1-640604-7
63.40 [2.496]	16	1-640604-6
59.44 [2.340]	15	1-640604-5
55.47 [2.184]	14	1-640604-4
51.51 [2.028]	13	1-640604-3
47.55 [1.872]	12	1-640604-2
43.59 [1.716]	11	1-640604-1
39.62 [1.560]	10	1-640604-0
35.66 [1.404]	9	640604-9
31.70 [1.248]	8	640604-8
27.74 [1.092]	7	640604-7
23.77 [.936]	6	640604-6
19.81 [.780]	5	640604-5
15.85 [.624]	4	640604-4
11.89 [.468]	3	640604-3
7.92 [.312]	2	640604-2

- 1 MATERIAL: CONNECTOR - NYLON UL94V-2 (ORANGE).
CONTACTS - 0.30[.012] THICK COPPER ALLOY
(BRIGHT TIN-LEAD 0.00203[.000080] MIN. THICK FOR CONTACTS 640604-2 THRU 2-640604-4)
(MATTE WHISKER MITIGATED TIN 0.00203[.000080] MIN THICKNESS OVER NICKEL UNDERPLATE FOR CONTACTS 3-640604-2 THRU 5-640604-4).
- 2 CONTACTS ACCEPT 18 AWG WIRE WITH 2.41[.095] MAX INSULATION DIAMETER.
- 3 CONTACTS MUST ACCEPT 1.14±0.03[.045±.001] SQUARE POST AND REMAIN LOCKED IN POSITION.
- 4 IDENTIFICATION NUMBER FOR LAST CIRCUIT MAY NOT APPEAR ON ALL ASSEMBLIES.
- 5 DIMENSIONS IN BRACKETS ARE IN INCHES.
- 6 HOUSING FEATURES ARE: FEED-THRU WITHOUT LOCKING RAMP.
- 7 OBSOLETE PARTS: OBSOLETE CIS STREAMLINING PER D.RENAUD/D.SINISI

SUPERSEDED 7
 SUPERSEDED 7
 OBSOLETE
 SUPERSEDED 7

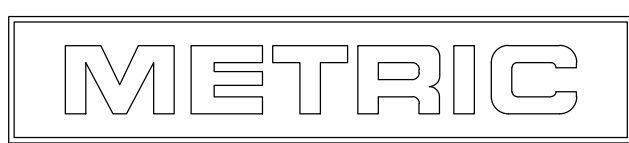

THIS DRAWING IS A CONTROLLED DOCUMENT.		DWN B. LEWIS 12FEB91		
DIMENSIONS: mm [INCHES]		CHK R. SWING 12FEB91		
TOLERANCES UNLESS OTHERWISE SPECIFIED:		APVD D. CLARK 19FEB91	NAME	
0 PLC ± -		PRODUCT SPEC		MTA-156 CONNECTOR ASSEMBLY, 18 AWG, STANDARD
1 PLC ± -		APPLICATION SPEC		
2 PLC ± -		108-1051		SIZE A2
3 PLC ± 0.13 [.005]		114-1020		
4 PLC ± -		WEIGHT -		CAGE CODE 00779
ANGLES ± -		CUSTOMER DRAWING		DRAWING NO C-640604
MATERIAL 1		FINISH 1		RESTRICTED TO -
		SCALE 4:1		SHEET 1 OF 1
				REV U1