Panasonic NFC-tag Development kit Installation Manual

Ver 2.30

Automotive & Industrial Systems Company
Panasonic Corporation

2013/10/25

Development kit ~ Outline(1)

1. Structure

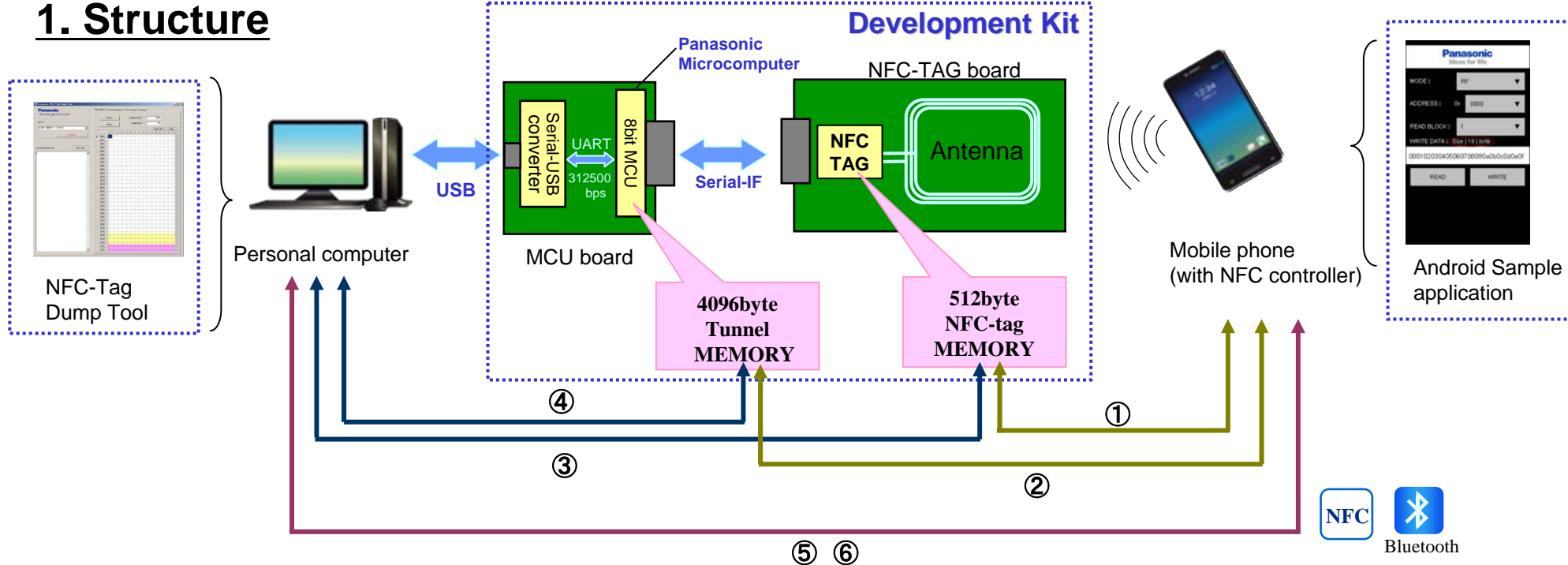

※ Tunnel memory = microcomputer memory
※ Serial-IF : [MN63Y1208 / MN63Y1213] I2C 100Kbps
[MN63Y1210A] UART 9600bps,38400bps / Clock Synchronous Serial 1Mbps

2. Function

- ① Read/Write NFC-tag memory from mobile phone with NFC function
- ② Read/Write Tunnel memory from mobile phone with NFC function
- ③ Read/Write NFC-tag memory from PC(microcomputer)
- ④ Read/Write Tunnel memory from PC
- ⑤ Write Files from mobile Phone to PC by NFC
- ⑥ Write Files from mobile Phone to PC by Bluetooth (Send Pairing information by NFC)

Development kit ~ Outline(2)

3. Software Version

In this document, we have assumed the use of the following software.

Software		Version	File Name	Outline
Microcomputer Software		2.20	— ※It is written to the Microcomputer board	Control Software of the Microcomputer Board
PC Software		2.30	NFCTAG_DumpTool_v230.exe	Read/Write memory of NFC-TAG / Microcomputer form PC
Android Software	Read/Write	1.50	Panasonic_TagReaderWriterFBRT_v150.apk	Read/Write memory of NFC-TAG / Microcomputer from Mobile Phone
	File Transfer	1.50	Panasonic_TagFileTx_v150.apk	Write Files(photo data) from mobile Phone to PC
	NFC-TAG setting	1.50	Panasonic_TagSetting1208_v150.apk	MN63Y1208 Setting
		1.50	Panasonic_TagSetting1210_v150.apk	MN63Y1210A Setting
		1.50	Panasonic_TagSetting1213_v150.apk	MN63Y1213 Setting

Installation (1)

Step1. board Setting

Please refer board connection of the following figure.

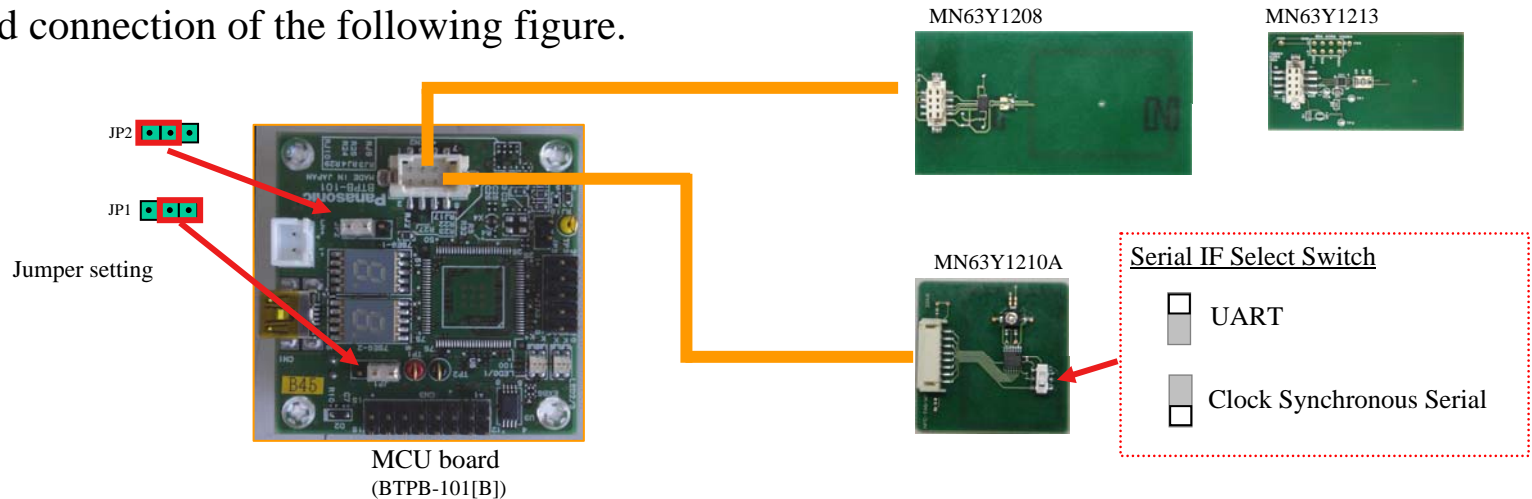

Step2. install driver and Application (for PC)

(1) Please download and install drivers from the following sites.

- Microsoft .NET Framework 4 Client Profile
download site <http://www.microsoft.com/en-us/download/details.aspx?id=17113>
- Virtual COM Port Driver (FTDI)
download site <http://www.ftdichip.com/Drivers/VCP.htm>

※ Since a driver demand screen is displayed at the time of board connection to the PC,
please specify the downloaded driver.

(2) Please copy an application file to a personal computer.

Sample Application : NFCTAG_DumpTool_vXXX.exe

※ Target OS: Microsoft Windows XP SP3 / Windows 7

Installation (2)

(3) Please download and install the library file from the following site. (for Bluetooth Control)

- **32feet.NET** (<http://32feet.codeplex.com/>)

download site <http://32feet.codeplex.com/downloads/get/386489>

※ file name : 32feet.NET 3.5.zip

- PC Application needs the library file that is included in “32feet.NET 3.5.zip”. (**InTheHand.Net.Personal.dll**)
- Please install the library file (**InTheHand.Net.Personal.dll**) in the same directory as the PC Application.

Install Step (run Steup.exe)

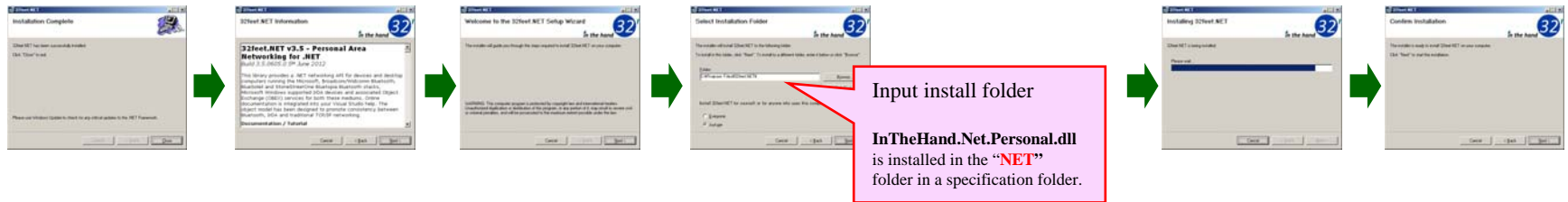

※ When using Bluetooth, Bluetooth function is required for the personal computer.

We use following USB-Bluetooth Adapter

BT-MicroEDR2X (PLANEX COMMUNICATIONS INC.)

<http://www.planex.co.jp/product/bluetooth/bt-microedr2x/>

About the Bluetooth driver

OS standard driver of Microsoft should be used for the Bluetooth driver.

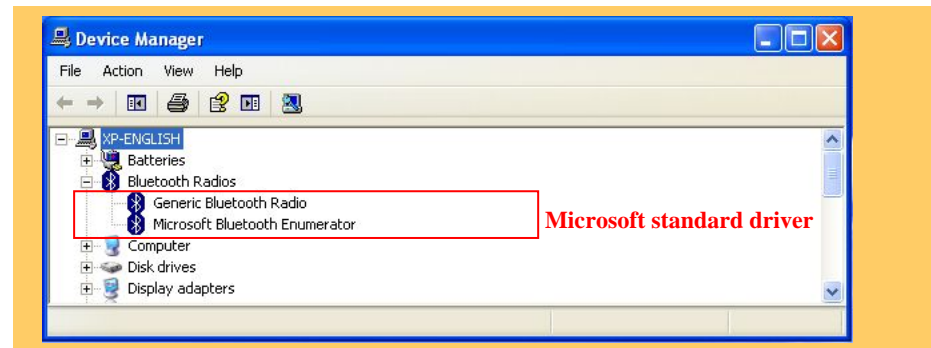
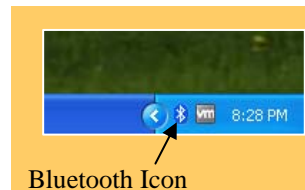

Installation (3)

Step3. install Android Application

Please install Android Application to the mobile Phone

Android Sample Application

- Panasonic_TagReaderWriterFBRT_vXXX.apk
- Panasonic_TagFileTx_vXXX.apk
- Panasonic_TagSettingXXXX_vXXX.apk

(Read/Write Sample Application)

(File Transfer Sample Application)

(MN63Y1208/1210A/1213 Tag Setting Application)



TagReaderWriterFBRT

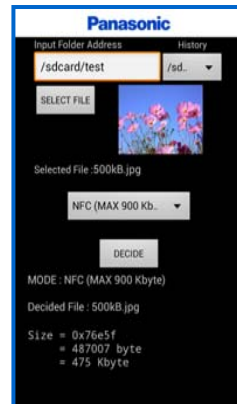

TagFileTx

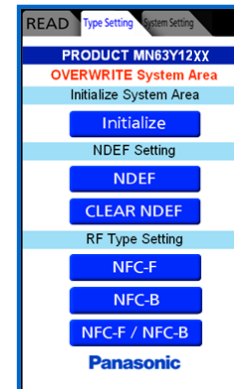

TagSetting1208
TagSetting1213

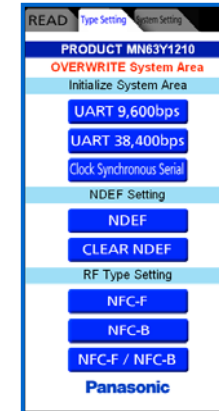

TagSetting1210

Installation (4)

Step4. Antenna setup

Please set up the serial communicate mode of the Antenna board. (MN63Y1210A only)

■ MN63Y1210

Serial Type : UART / Clock Synchronous Serial

(1) Board Setting

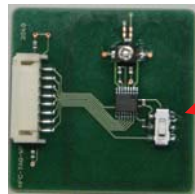

MN63Y1210

Serial IF Select Switch

- UART
- Clock Synchronous Serial

(2) Serial Type Setting

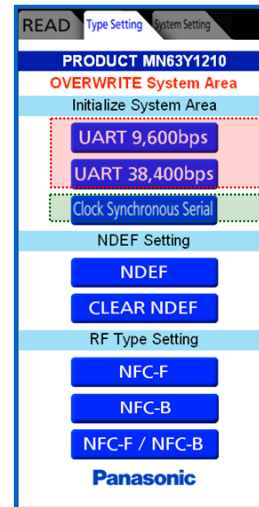

UART

Clock Synchronous Serial

It initializes using the application for a Tag setup (Panasonic_TagSetting1210)

(1) A mobile phone is brought close to TAG after starting application

(2) Push button

Installation (5)

Step5. Connection with a PC

Please connect a board with a personal computer using a USB cable.

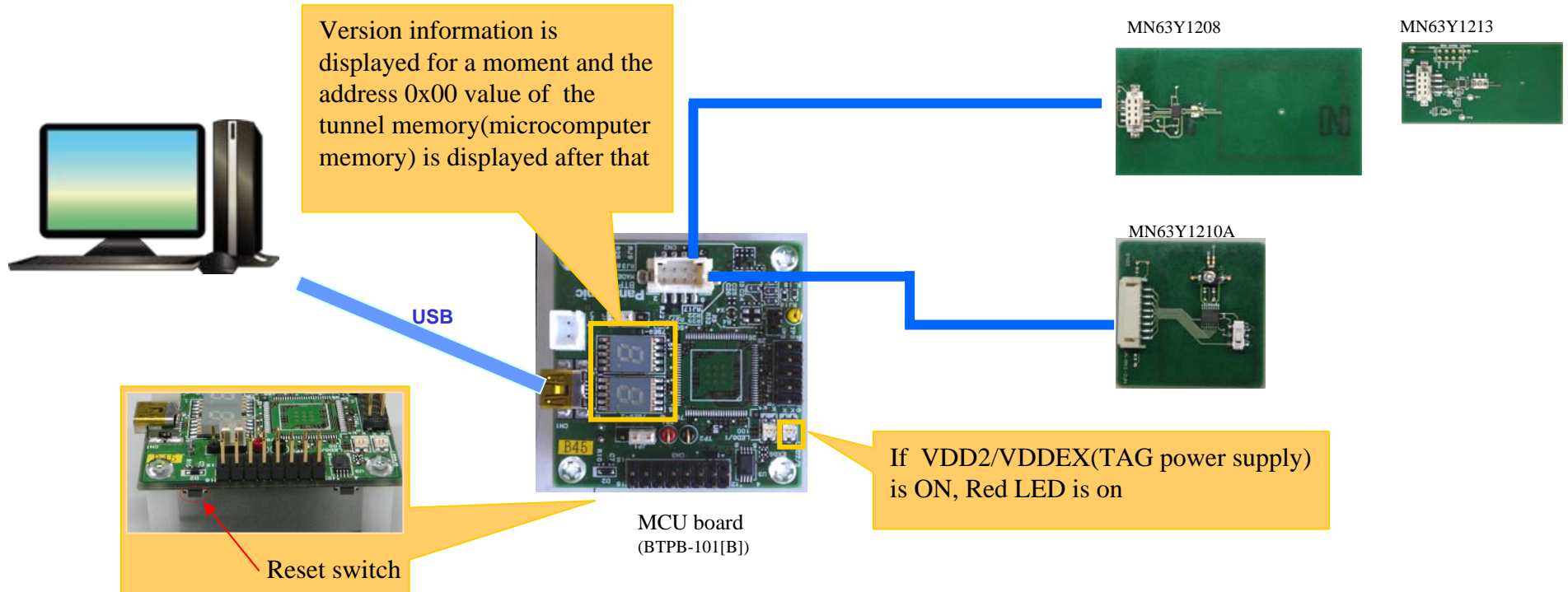

How to use (PC Application)

Step6. Start PC Sample Application

■ connect to target board

STEP1

Select virtual COM port
(connect to the board)

STEP2

push "Connect" button

STEP3

push the reset switch of the board.

STEP4

A starting log is displayed

Select

(1) TAG Power supply mode

(2) Log mode

- Enable All Log

- Disable Log (The file Transfer mode is disabled)

※Please select "Enable File Transfer Log" to perform the file transfer where log display is disabled

■ Read/Write memory

STEP5

Input memory Address
(16-byte alignment hexadecimal number)

※A click of a cell will input an address automatically.

STEP6

Input Length (hexadecimal number)

[NFC-Tag Memory]

Read 0x01 ~ 0x200 [1~512 byte]

Write 0x01 ~ 0xFB [1~251 byte]

[Tunnel Memory]

Read 0x01 ~ 0x1000 [1~4096 byte]

Write 0x01 ~ 0xFF [1~255 byte]

STEP7

push "Read" or "Write" button

※before you write, please set value to cell.

USER AREA

CONFIG AREA

SYSTEM AREA

It is possible to copy(Ctrl+C) and paste(Ctrl+V) while selecting cells

How to use (PC Application)

PC Sample Application(File Transfer)

If the mobile phone that is performing android application (Panasonic_TagFileTx) is brought close to NFC-TAG, a file transfer will be started automatically and information will be displayed on the “file Transfer” tab.

The following icon is displayed during a file transfer by Bluetooth.



Waiting for Bluetooth connection



file transfer by Bluetooth

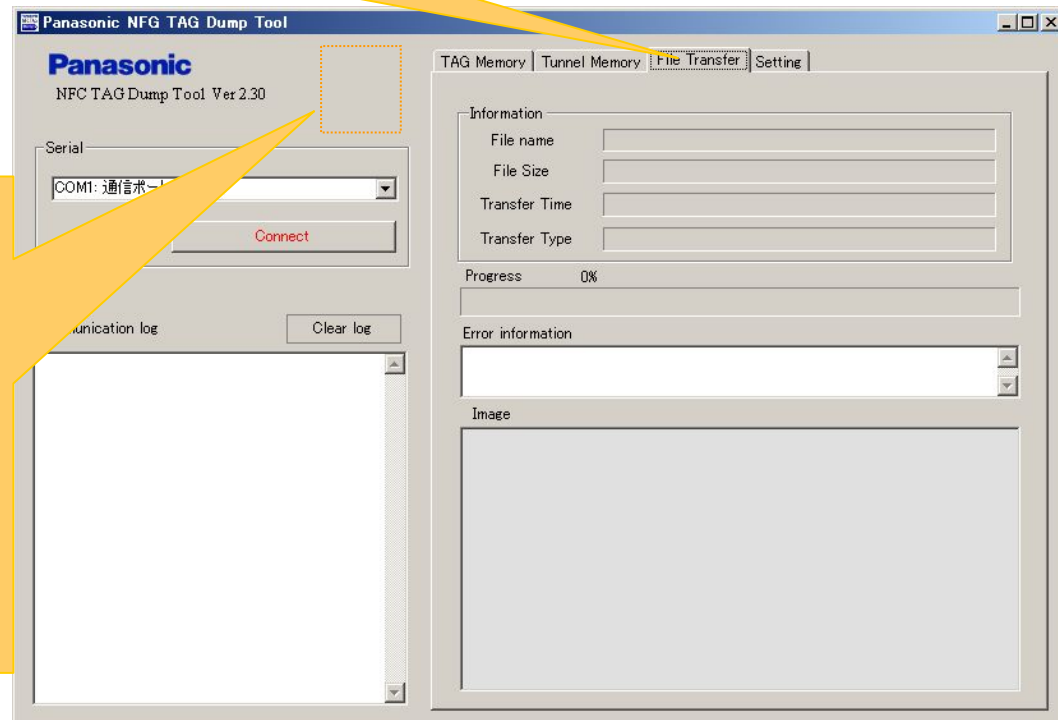

How to use (PC Application)

※Bluetooth File Transfer Sequence

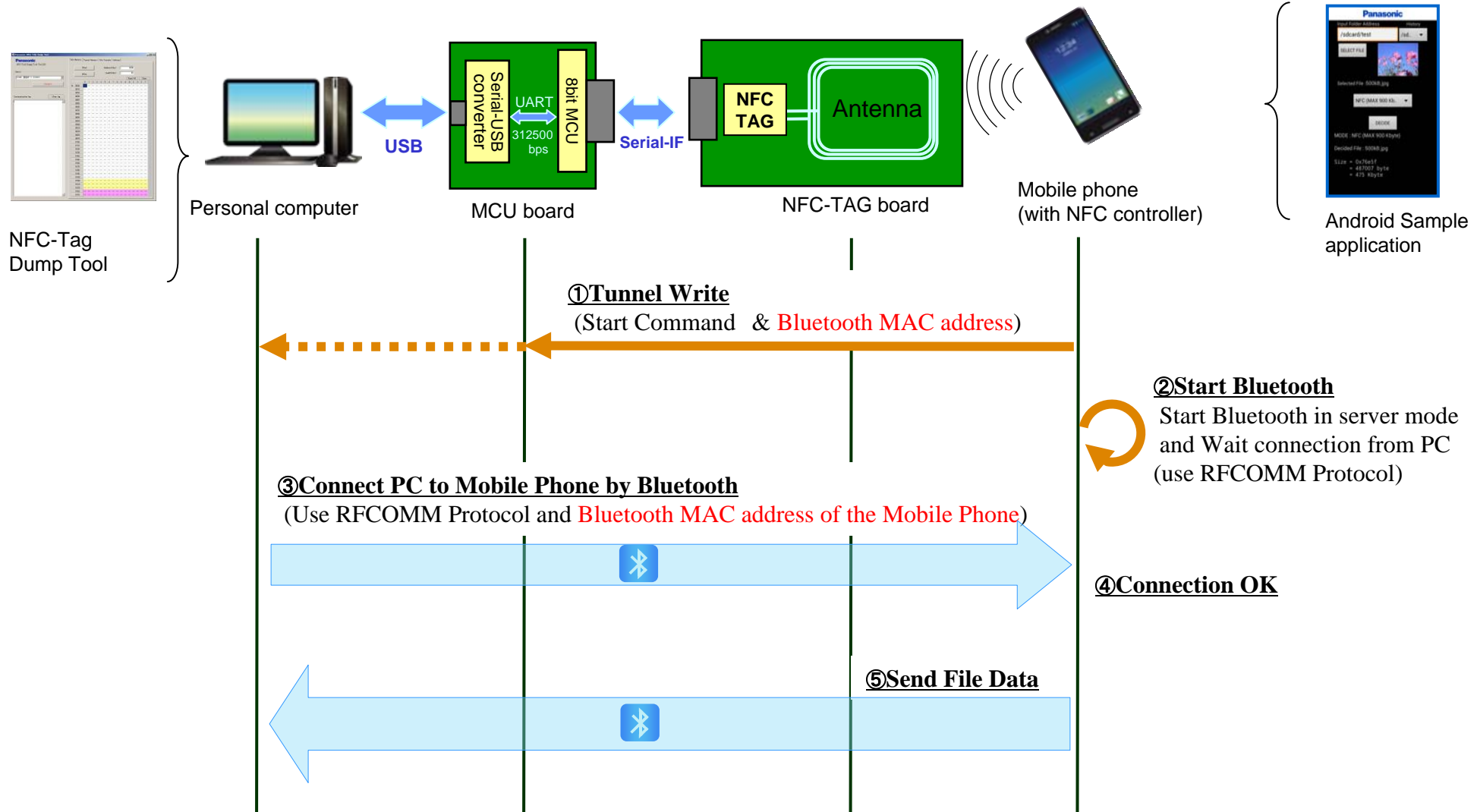

Change history

Version	Date	Changed Item
2.00	2012/11/22	New creation
2.20	2013/09/05	Version up all PC/Android applications.
2.21	2013/10/03	Added MN63Y1213
2.30	2013/10/25	Version up PC application. Added Information of Software Version.

Request for your special attention and precautions in using the technical information and semiconductors described in this book

- (1) If any of the products or technical information described in this book is to be exported or provided to non-residents, the laws and regulations of the exporting country, especially, those with regard to security export control, must be observed.
- (2) The technical information described in this book is intended only to show the main characteristics and application circuit examples of the products. No license is granted in and to any intellectual property right or other right owned by Panasonic Corporation or any other company. Therefore, no responsibility is assumed by our company as to the infringement upon any such right owned by any other company which may arise as a result of the use of technical information described in this book.
- (3) The products described in this book are intended to be used for general applications (such as office equipment, communications equipment, measuring instruments and household appliances), or for specific applications as expressly stated in this book.
Consult our sales staff in advance for information on the following applications:
 - Special applications (such as for airplanes, aerospace, automotive equipment, traffic signaling equipment, combustion equipment, life support systems and safety devices) in which exceptional quality and reliability are required, or if the failure or malfunction of the products may directly jeopardize life or harm the human body.It is to be understood that our company shall not be held responsible for any damage incurred as a result of or in connection with your using the products described in this book for any special application, unless our company agrees to your using the products in this book for any special application.
- (4) The products and product specifications described in this book are subject to change without notice for modification and/or improvement. At the final stage of your design, purchasing, or use of the products, therefore, ask for the most up-to-date Product Standards in advance to make sure that the latest specifications satisfy your requirements.
- (5) When designing your equipment, comply with the range of absolute maximum rating and the guaranteed operating conditions (operating power supply voltage and operating environment etc.). Especially, please be careful not to exceed the range of absolute maximum rating on the transient state, such as power-on, power-off and mode-switching. Otherwise, we will not be liable for any defect which may arise later in your equipment.
Even when the products are used within the guaranteed values, take into the consideration of incidence of break down and failure mode, possible to occur to semiconductor products. Measures on the systems such as redundant design, arresting the spread of fire or preventing glitch are recommended in order to prevent physical injury, fire, social damages, for example, by using the products.
- (6) Comply with the instructions for use in order to prevent breakdown and characteristics change due to external factors (ESD, EOS, thermal stress and mechanical stress) at the time of handling, mounting or at customer's process. When using products for which damp-proof packing is required, satisfy the conditions, such as shelf life and the elapsed time since first opening the packages.
- (7) This book may be not reprinted or reproduced whether wholly or partially, without the prior written permission of our company.