

© COPYRIGHT 1976 BY AMP INCORPORATED, HARRISBURG, PA. ALL INTERNATIONAL RIGHTS RESERVED. AMP INCORPORATED PRODUCTS COVERED BY U. S. AND FOREIGN PATENTS AND/OR PATENTS PENDING.

REVISIONS						
P	F	ZONE	LTR	DESCRIPTION	DATE	APPROVED
F	✓		F	REVISED & REDRAWN	DS 11-16-76	<i>M.B.</i>
			G	REVISED PER OH14-0192-05	1-06	PY

UNPUBLISHED COPY NOT TO BE REPRODUCED NOR PUBLISHED WITHOUT WRITTEN PERMISSION OF AMP INCORPORATED.

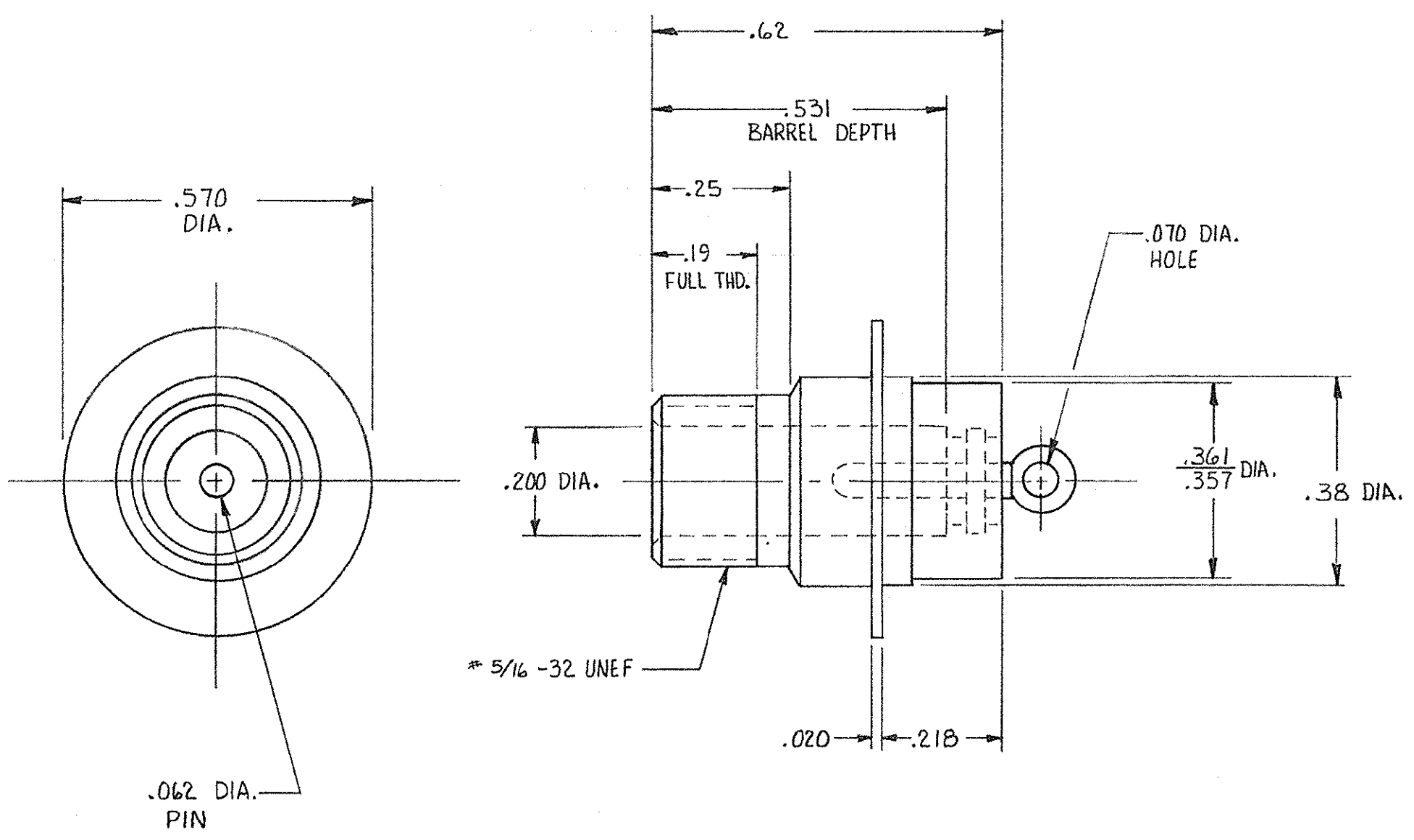

NOTE:  
 1. THIS RECEPTACLE IS HERMETICALLY SEALED.  
 2. SCREW THREAD MEASUREMENT IN ACCORDANCE WITH H2B HANDBOOK. (3 WIRE METHOD). USING WIRE .01804 DIA.- MEASUREMENT OVER WIRE SHALL BE .318 / .307.

5-861252-1	AS SHOWN WITH TIN PLATED PIN & FLANGE
861252-1	AS SHOWN WITH TIN-LEAD PLATED PIN & FLANGE

				CONTRACT NO		PART NO	
				DR DIGK STONE 11-16-76		AMP INCORPORATED Elizabethtown, Pa.	
				CHK		NAME	
				APPD <i>M. Anderson</i> 11/10/76		FLANGED RECEPTACLE	
				APPD		LGH - 1/2	
				DSGN APPD		W J H	
				OTHER APPD		SIZE CODE IDENT NO DRAWING NO	
				FINISH		C 00779 861252	
				BLACK		SCALE	
				NEXT ASSY		SHEET 1 OF 1	
				FINAL ASSY			
				NEXT ASSY			
				USED ON			
				QTY REQD		APPLICATION	

# Mouser Electronics

Authorized Distributor

Click to View Pricing, Inventory, Delivery & Lifecycle Information:

[TE Connectivity:](#)

[861252-1](#)