

NPN Silicon Phototransistors

Types OP600A, OP600B, OP600C

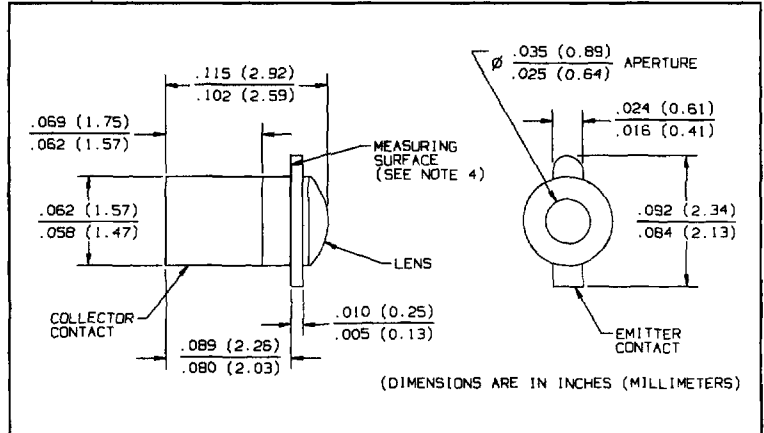

Features

- Narrow receiving angle
- Variety of sensitivity ranges
- Enhanced temperature range
- Ideal for direct mounting in PC boards
- Mechanically and spectrally matched to the OP123 and OP223 series devices
- TX/TXV processing available (see Hi-Rel section)

Description

The OP600 series device consists of an NPN silicon phototransistor mounted in a hermetically sealed "Pill" type package. The narrow receiving angle provides excellent on-axis coupling. These devices are 100% production tested using infrared light for close correlation with Optek GaAs and GaAlAs emitters.

Absolute Maximum Ratings ($T_A = 25^\circ\text{C}$ unless otherwise noted)

Collector-Emitter Voltage	25 V
Emitter-Collector Voltage	5.0 V
Storage Temperature Range	-65°C to $+150^\circ\text{C}$
Operating Temperature Range	-65°C to $+125^\circ\text{C}$
Soldering Temperature (5 sec. with soldering iron)	$260^\circ\text{C}^{(1)(2)}$
Power Dissipation	50 mW ⁽³⁾
Continuous Collector Current	50 mA

Notes:

- (1) Refer to Application Bulletin 202 which discusses proper techniques for soldering Pill type devices to PC boards.
- (2) No clean or low solids, RMA flux is recommended. Duration can be extended to 10 sec. max. when flow soldering.
- (3) Derate linearly $0.5\text{mW}/^\circ\text{C}$ above 25°C .
- (4) Junction temperature maintained at 25°C .
- (5) Light source is a GaAlAs LED, peak Wavelength = 890 nm, providing an irradiance of $2.5\text{ mW}/\text{cm}^2$. The source irradiance is not necessarily uniform over the entire lens area of the unit under test.

Typical Performance Curves

Typical Spectral Response

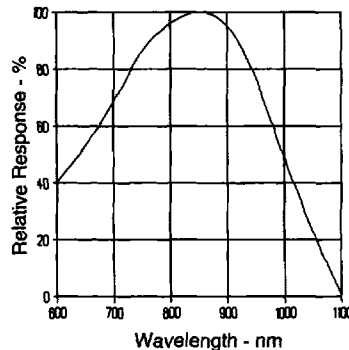

Coupling Characteristics of OP123 and OP600

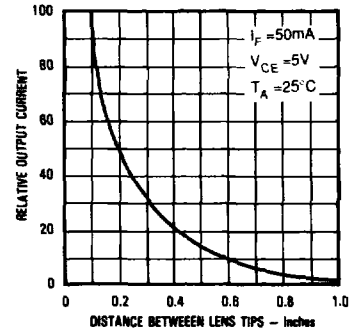

Types OP600A, OP600B, OP600C

Electrical Characteristics ($T_A = 25^\circ\text{C}$ unless otherwise noted)

SYMBOL	PARAMETER	MIN	TYP	MAX	UNITS	TEST CONDITIONS
$I_{C(ON)}^{(4)}$	On-State Collector Current OP600C OP600B OP600A	0.30 0.60 1.20		1.8	mA mA mA	$V_{CE} = 5\text{ V}$, $E_e = 2.5\text{ mW/cm}^2(5)$
I_{CEO}	Collector Dark Current				nA	$V_{CE} = 10\text{ V}$, $E_e = 0$
$V_{(BR)CEO}$	Collector-Emitter Breakdown Voltage	25			V	$I_C = 100\text{ }\mu\text{A}$
$V_{(BR)ECO}$	Emitter-Collector Breakdown Voltage	5.0			V	$I_E = 100\text{ }\mu\text{A}$
$V_{CE(SAT)}^{(4)}$	Collector-Emitter Saturation Voltage			0.40	V	$I_C = 0.15\text{ mA}$, $E_e = 2.5\text{ mW/cm}^2(5)$
t_r	Rise Time		15		μs	$V_{CC} = 5\text{ V}$, $I_C = 0.80\text{ mA}$, $R_L = 1\text{ k}\Omega$, See Test Circuit
t_f	Fall Time		15		μs	

Typical Performance Curves

Collector Dark Current vs. Ambient Temperature

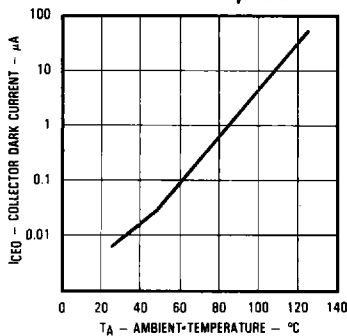

Normalized Collector Current vs. Ambient Temperature

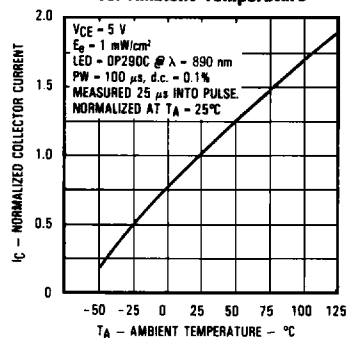

Rise and Fall Time vs. Load Resistance

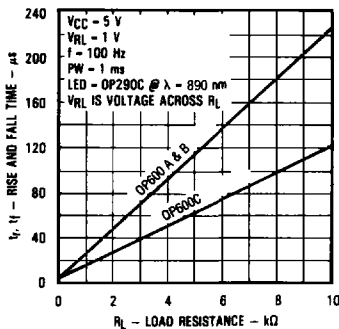

Normalized Collector Current vs. Angular Displacement

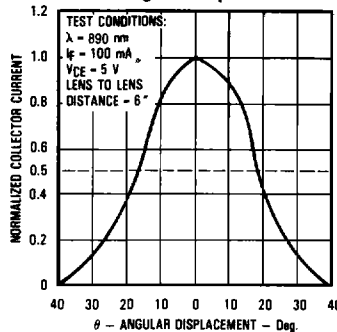

Switching Time Test Circuit

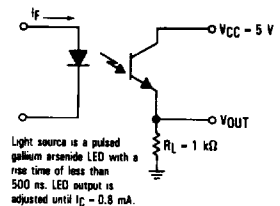

Optek reserves the right to make changes at any time in order to improve design and to supply the best product possible.

Optek Technology, Inc. 1215 W. Crosby Road Carrollton, Texas 75006 (972)323-2200 Fax (972)323-2396