

PART NO.			"A"
FOR #4 (M-3) SCREW	FOR #6 (M-3.5) SCREW	FOR #8 (M-4) SCREW	
SSRS4-2-01	-	-	1/8 (3.2)
SSRS4-3-01	-	-	3/16 (4.8)
SSRS4-4-01	SSRS6-4-01	SSRS8-4-01	1/4 (6.4)
SSRS4-5-01	SSRS6-5-01	SSRS8-5-01	5/16 (7.9)
SSRS4-6-01	SSRS6-6-01	SSRS8-6-01	3/8 (9.5)
SSRS4-7-01	SSRS6-7-01	SSRS8-7-01	7/16 (11.1)
SSRS4-8-01	SSRS6-8-01	SSRS8-8-01	1/2 (12.7)
SSRS4-10-01	SSRS6-10-01	SSRS8-10-01	5/8 (15.9)
-	SSRS6-12-01	SSRS8-12-01	3/4 (19.1)
-	SSRS6-14-01	SSRS8-14-01	7/8 (22.2)
-	SSRS6-16-01	SSRS8-16-01	1.0 (25.4)

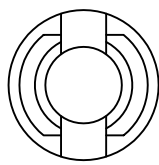

SERIES NO.	DIM. "B"	DIM. "C"	SCREW SIZE	MOUNTING HOLE DIA. ±.003(0.08)
SSRS4	.260 (6.6)	.125 (3.1)	#4	.187 (4.75)
SSRS6	5/16 (7.9)	.153 (3.9)	#6	.234 (5.94)
SSRS8	5/16 (7.9)	.169 (4.3)	#8	.234 (5.94)

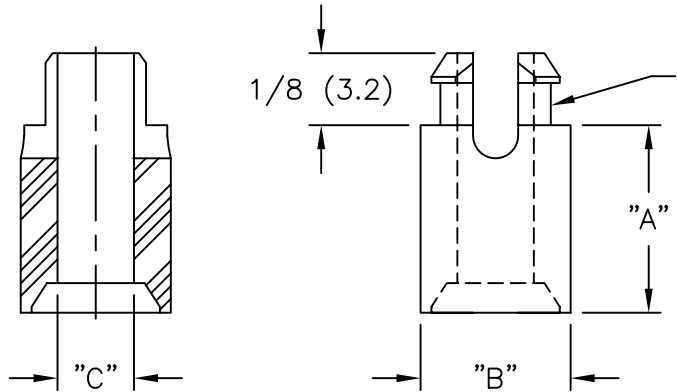

NOTES:

- MATERIAL: NYLON 66 (RMS-01).
FLAME RETARDANT: NYLON (RMS-19),
BY SPECIAL ORDER.
- COLOR: NATURAL.

D CHANGED FILE NUMBER SM 05.10.01		C TOLERANCES UNLESS NOTED .XX=±.010 .XXX=±.005 FRAC=1/64 ANG=1°		FILE # SSRS	DWN: P.B.	APP:	DWG IN IN (MM) FINAL	
C ADDED 3 NEW SIZES TO #6 & #8 SCREW M.B. 9.15.00		.XX=±.010 .XXX=±.005 FRAC=1/64 ANG=1°		MAT'L: SEE NOTES	DT: 03-16-94	DT:		
B DIM. 5/16(7.9) WAS 5/16(7.1) J.L. 4/22/99		.XX=±.010 .XXX=±.005 FRAC=1/64 ANG=1°		RE: RICHCO, INC.	RICHCO INC. PO BOX 804238, CHICAGO, 60680 (773) 539-4060			
A MAT'L RMS-19 ADDED J.L. 12.10.97		.XX=±.010 .XXX=±.005 FRAC=1/64 ANG=1°						
REV DESCRIPTION ENGR DATE								

TITLE: STACKABLE, SELF RETAINING SPACER