



DC-SE SERIES

General purpose DC LVDT

SPECIFICATIONS

- Single-Ended DC operation
- Low 6mA current consumption
- Stroke ranges from 0.1 to 6 inches
- 0.25% linearity
- Stainless steel housing
- Double magnetic shielding
- EMI/ESD protected
- 1 meter long shielded cable
- Captive core option

The DC-SE Series LVDTs operate on a single-ended DC power supply, and provide either a 0 to +5VDC or +1 to +6VDC output signal (wiring dependent) over their full range of displacement. The extremely linear and low noise output makes the DS-SE Series the perfect choice for interfacing to unipolar inputs of analog-to-digital converters, PLC's, and various data collection systems.

The DC-SE is internally regulated, thus providing immunity to line ripple and allowing operation from unregulated power sources of between 8.5 and 28VDC. The very low typical 6mA current draw is ideal for remote or battery powered applications. The highly stable oscillator provides excellent temperature performance throughout the operating temperature range, while synchronous demodulation insures superb noise rejection.

The built-in EMI/ESD protection and the shielded cable permit operation in noisy industrial environments, with double magnetic shielding providing the utmost protection from stray fields.

Like in most of our LVDTs, the DC-SE windings are vacuum impregnated with a specially formulated, high temperature, flexible resin, and the coil assembly is potted inside its housing with a two-component epoxy. This provides excellent protection against hostile environments such as high humidity, vibration and shock.

Available in a variety of stroke ranges from 0.1 to 6 inches, the DC-EC Series can be configured with a number of standard options including metric threaded core, guided core and small diameter/low mass core.

Captive core option: The DC-EC features an optional captive core design (available for most models) that greatly simplifies installation. The core rod and bearing assembly includes a Bronze bearing on the front end for self-alignment, while a PTFE sleeve allows low-friction travel through the stainless steel boreliner (spool tube). The core rod and the bearing assembly are both field serviceable.

FEATURES

- Unipolar DC operation
- Low power consumption
- Shock and vibration tolerant
- Captive core option (*available on select models*)
- AISI 400 Series stainless steel housing
- CE compliant
- Calibration certificate supplied with each unit

APPLICATIONS

- Factory floor automation
- Position feedback
- Data collection
- Process control
- Metrology
- Portable / battery powered measurements
- General industrial

PERFORMANCE SPECIFICATIONS

ELECTRICAL SPECIFICATIONS							
Parameter	DC-SE 100	DC-SE 250	DC-SE 500	DC-SE 1000	DC-SE 2000	DC-SE 4000	DC-SE 6000
Stroke range	0.10 [2.54]	0.25 [6.35]	0.50 [12.7]	1.0 [25.4]	2.0 [50.8]	4.0 [101.6]	6.0 [152.4]
Sensitivity, VDC/inch	50	20	10	5	2.5	1.25	0.833
Sensitivity, VDC/mm	1.97	0.787	0.394	0.197	0.098	0.0492	0.0328
Input voltage	+8.5 to +28VDC						
Line regulation	1mV/VDC, maximum; 0.2mV/VDC, typical						
Input current	10mA maximum; 6mA typical						
Output voltage	0 to +5VDC (4 wire), +1 to +6VDC (3 wire) - Increases when the core is displaced towards the cable						
Output current	5mA maximum						
Non-linearity	±0.25% of FR, maximum						
Output ripple & noise	10 mVRMS, maximum						
Stability	0.125% of FSO						
Temp. coefficient of sensitivity	0.028%/°F [0.05%/C], maximum						
Frequency response	200 Hertz @ -3dB						
ENVIRONMENTAL SPECIFICATIONS & MATERIALS							
Temperature range	-13°F to +185°F [-25°C to 85°C] Operating; -65°F to +257°F [-55°C to 125°C] Survival						
Shock survival	250 g (11ms half-sine)						
Vibration tolerance	10 g up to 2kHz						
Housing material	AISI 400 Series stainless steel						
Electrical connection	Cable with 4 conductor, 28AWG, stranded copper, braided shield and polyurethane jacket, 39 inches [1 meter] long. Shield is connected to case.						
IEC 60529 rating	IP61						

Notes:

All values are nominal unless otherwise noted; Dimensions are in inch [mm] unless otherwise noted

FR: Full Range is the stroke range, end to end; FR=S for 0 to S stroke range

FSO (Full Scale Output): Largest absolute value of the outputs measured at the ends of the range

WIRING SCHEMATIC & BLOCK DIAGRAM

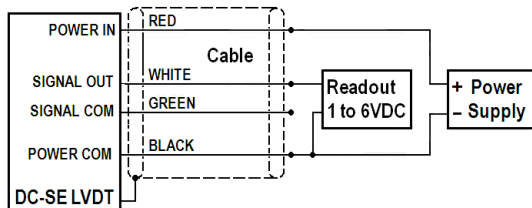

3-wire hookup for +1 to +6VDC output

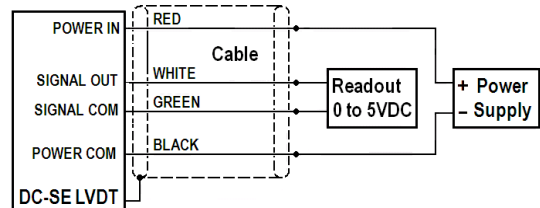

4-wire hookup for 0 to +5VDC output

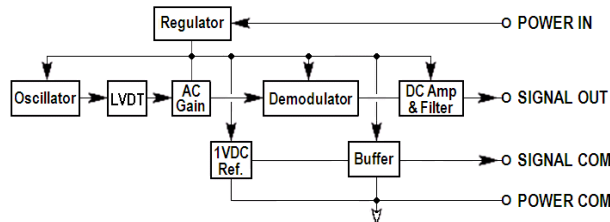

Important: NEVER connect SIG COM and PWR COM together; NEVER connect SIG COM to other DC-SE's

DC-SE SERIES

General purpose DC LVDT

MECHANICAL SPECIFICATIONS – NON-CAPTIVE CORE (STANDARD)

Parameter	DC-SE 100	DC-SE 250	DC-SE 500	DC-SE 1000	DC-SE 2000	DC-SE 4000	DC-SE 6000
Main body length "A"	3.51 [89.2]	4.36 [110.7]	5.20 [132.1]	6.89 [175.0]	8.87 [225.3]	12.25 [311.2]	17.3 [439.4]
Core length "B"	0.585 [14.9]	1.10 [27.9]	1.80 [45.7]	3.00 [76.2]	3.80 [96.5]	5.30 [134.6]	6.20 [157.5]
Length of bore "C"	1.21 [30.7]	2.06 [52.2]	2.91 [73.8]	4.59 [116.7]	6.57 [166.8]	9.95 [252.8]	15.06 [382.5]
Center of core position at null "P"	0.51 [13.0]	0.93 [23.6]	1.35 [34.3]	2.20 [55.9]	3.19 [81.0]	4.88 [124.0]	7.56 [192.0]
Body weight oz [gram]	2.54 [72]	3.21 [91]	3.39 [96]	4.38 [124]	6.25 [177]	8.33 [236]	10.48 [297]
Core weight oz [gram]	0.035 [1]	0.11 [3]	0.18 [5]	0.28 [8]	0.35 [10]	0.53 [15]	0.64 [18]

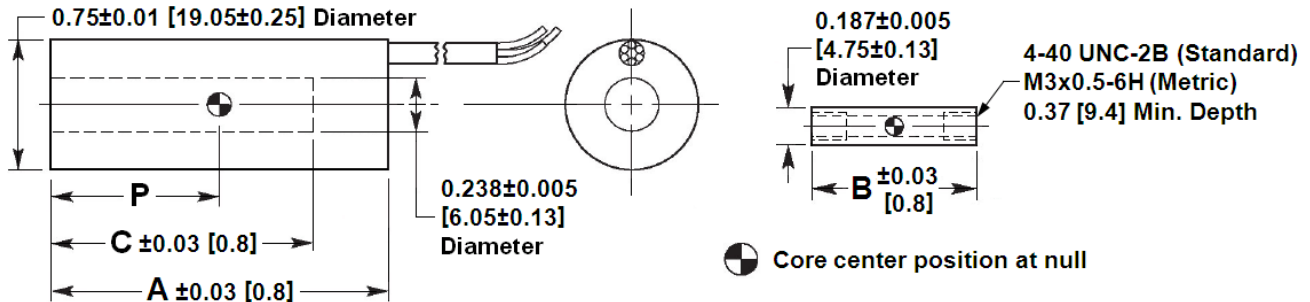

Dimensions are in inch [mm]

MECHANICAL SPECIFICATIONS – CAPTIVE CORE OPTION

Parameter	DC-SE 100	DC-SE 250	DC-SE 500	DC-SE 1000	DC-SE 2000	DC-SE 4000	DC-SE 6000
Main body length "A"	3.85 [97.8]	4.70 [119.4]	5.54 [140.7]	7.23 [183.6]	9.21 [233.9]	12.59 [319.8]	17.64 [448.1]
Core rod position at null "R"	3.69 [93.7]	4.28 [108.7]	4.75 [120.6]	6.04 [153.4]	7.90 [200.7]	10.52 [267.2]	15.27 [387.9]
Center of core position at null "P"	0.85 [21.6]	1.27 [32.2]	1.69 [42.9]	2.54 [64.5]	3.53 [89.7]	5.22 [132.6]	7.90 [200.7]
Weight, oz [gram]	1.52 [43]	4.09 [116]	4.34 [123]	5.51 [156]	7.62 [216]	10.13 [287]	12.92 [366]

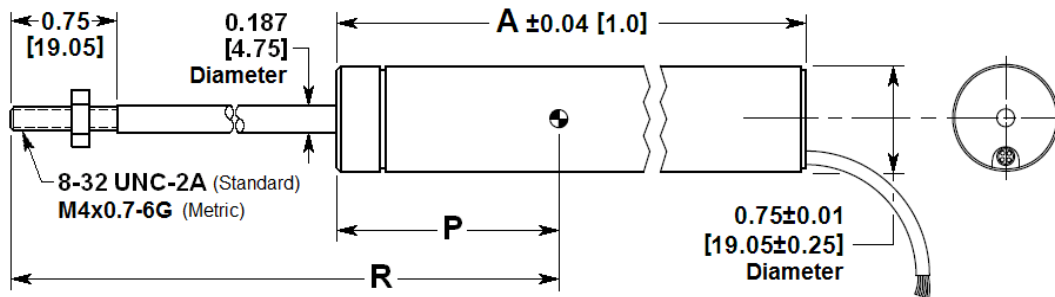

Dimensions are in inch [mm]

DC-SE SERIES

General purpose DC LVDT

ORDERING INFORMATION

Description	Model	Part Number
0.10 inch LVDT	DC-SE 100	02560990-000
0.25 inch LVDT	DC-SE 250	02560991-000
0.50 inch LVDT	DC-SE 500	02560992-000
1 inch LVDT	DC-SE 1000	02560993-000

Description	Model	Part Number
2 inch LVDT	DC-SE 2000	02560994-000
4 inch LVDT	DC-SE 4000	02560995-000
6 inch LVDT	DC-SE 6000	02560996-000

OPTIONS	
Metric threaded core (M3 x 0.5-6H)	XXXXXXXX-006
Guided core	XXXXXXXX-010
Small-diameter/low-mass core (<i>consult factory for mass & dimensions</i>)	XXXXXXXX-020
Captive core	XXXXXXXX-200

Note: Add multiple option dash numbers together to determine proper ordering suffix

Example: DC-SE 1000, 1 inch stroke, with metric threaded and guided core, P/N 02560993-016

ACCESSORIES		
DC power supply (15VDC)	Model PSD 40-15	02291339-000
Core connecting rod, 6 inches long, 4-40 threads		05282946-006
Core connecting rod, 12 inches long, 4-40 threads		05282946-012
Core connecting rod, 24 inches long, 4-40 threads		05282946-024
Core connecting rod, 36 inches long, 4-40 threads		05282946-036
Core connecting rod, 6 inches long, M3x0.5 metric threads		05282977-006
Core connecting rod, 12 inches long, M3x0.5 metric threads		05282977-012
Mounting block		04560950-000

NORTH AMERICA

Measurement Specialties, Inc.,
a TE Connectivity Company
1000 Lucas Way
Hampton, VA 23666
United States
Phone: +1-800-745-8008
Fax: +1-757-766-4297
Email: sales@meas-spec.com

EUROPE

MEAS Deutschland GmbH (Europe)
a TE Connectivity Company
Hauert 13
D-44227 Dortmund
Germany
Phone: +49-(0)231-9740-0
Fax: +49-(0)231-9740-20
Email: info.de@meas-spec.com

ASIA

Measurement Specialties (China), Ltd.,
a TE Connectivity Company
No. 26 Langshan Road
Shenzhen High-Tech Park (North)
Nanshan District, Shenzhen 518057
China
Phone: +86-755-33305088
Fax: +86-755-33305099
Email: info.cn@meas-spec.com

TE.com/sensorsolutions

Measurement Specialties, Inc., a TE Connectivity company.

Accustar, American Sensor Technologies, AST, ATEXIS, DEUTSCH, IdentiCal, TruBlue, KPSI, Krystal Bond, Microfused, UltraStable, Measurement Specialties, MEAS, Schaevitz, TE Connectivity, TE, and the TE connectivity (logo) are trademarks of the TE Connectivity Ltd. family of companies. Other logos, product and company names mentioned herein may be trademarks of their respective owners.

The information given herein, including drawings, illustrations and schematics which are intended for illustration purposes only, is believed to be reliable. However, TE Connectivity makes no warranties as to its accuracy or completeness and disclaims any liability in connection with its use. TE Connectivity's obligations shall only be as set forth in TE Connectivity's Standard Terms and Conditions of Sale for this product and in no case will TE Connectivity be liable for any incidental, indirect or consequential damages arising out of the sale, resale, use or misuse of the product. Users of TE Connectivity products should make their own evaluation to determine the suitability of each such product for the specific application.

© 2015 TE Connectivity Ltd. family of companies All Rights Reserved.