



ALL RIGHTS RESERVED. NO PORTION OF THIS PUBLICATION, WHETHER IN WHOLE OR IN PART CAN BE REPRODUCED WITHOUT THE EXPRESS WRITTEN CONSENT OF SPC TECHNOLOGY.

SPC-F005.DWG

REVISIONS

DOC. NO. SPC-F005 * Effective: 7/8/02 * DCP No: 1398

DCP #	REV	DESCRIPTION	DRAWN	DATE	CHECKD	DATE	APPRVD	DATE
564	C	PARTS ADDED; WAS ON HMF-*--***-A	HYO	4/6/00	JC	10/6/00	JC	10/6/00
1892	D	Update To RoHS Compliant	EO	3/14/06	HO	3/15/06	HO	3/15/06

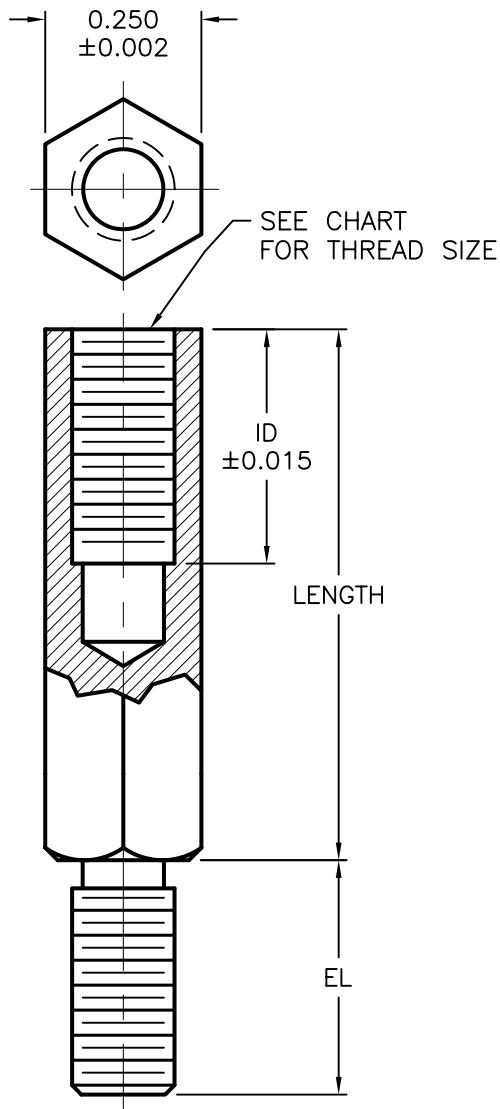

SPC TYPE NO.	THREAD SIZE Male & Female	LENGTH (INCHES)	INTERNAL THREAD DEPTH (ID)	EXTERNAL THREAD LENGTH (EL)
HMFB-4-250-A	4-40	0.250	0.130/0.150	0.187
HMFB-4-375-A		0.375		
HMFB-4-500-A		0.500		
2756		0.625		
2757		0.750		
2758		1.000		
HMFB-6-250-A	6-32	0.250	0.130/0.150	0.250
HMFB-6-375-A		0.375		
HMFB-6-500-A		0.500		
2759		0.625		
HMFB-6-750-A		0.750		
HMFB-6-1000-A		1.000		
HMFB-6-1500-A		1.500		
HMFB-6-2000-A		2.000		
2761	8-32	0.375	0.250	0.375
HMFB-8-500-A		0.500		
2760		0.625		
HMFB-8-750-A		0.750		
HMFB-8-1000-A		1.000		
HMFB-8-1500-A		1.500		
HMFB-8-2000-A		2.000		
HMFB-8-2500-A		2.500		
HMFB-8-3000-A	3.000			

MATERIAL:BRASS, NICKEL PLATED PER (QQ-N-290)

DISCLAIMER:
ALL STATEMENTS AND TECHNICAL INFORMATION CONTAINED HEREIN ARE BASED UPON INFORMATION AND/OR TESTS WE BELIEVE TO BE ACCURATE AND RELIABLE. SINCE CONDITIONS OF USE ARE BEYOND OUR CONTROL, THE USER SHALL DETERMINE THE SUITABILITY OF THE PRODUCT FOR THE INTENDED USE AND ASSUME ALL RISK AND LIABILITY WHATSOEVER IN CONNECTION THEREWITH.

TOLERANCES:
UNLESS OTHERWISE SPECIFIED
DECIMAL
.XXX ± 0.005

DRAWN BY:	DATE:
J.P.	4/15/93
CHECKED BY:	DATE:
J.C.	4/20/93
APPROVED BY:	DATE:
K.D.	4/20/93

DRAWING TITLE:
HEX STANDOFF, MALE/FEMALE, BRASS

SIZE	DWG. NO.	ELECTRONIC FILE	REV
A	TA-251	TA-251.DWG	D
SCALE: NTS	U.O.M.: INCHES	SHEET: 1 OF 1	