



Product Catalog

Advanced Switching and Magnetic Sensing Solutions

REDROCK™ RR110 TMR ANALOG SENSOR



RedRock™ RR110 TMR Analog Sensor

The RedRock 110 Series is an analog magnetic sensor, ideal for use in medical, industrial, automotive, and consumer applications. Based on patented Tunneling Magnetoresistance (TMR) technology, the RR110 Series excels even in low magnetic fields and with large air gaps. The RR110 Series offers high sensitivity in a small footprint package.



Features

- ▶ High sensitivity
- ▶ Stable temperature performance
- ▶ Resistant to mechanical stress
- ▶ REACH Compliant
- ▶ RoHS Compliant

IDEAL APPLICATIONS

- ▶ Door or lid closure detection
- ▶ Smart phones, tablets and laptops
- ▶ Proximity detection
- ▶ Position sensing
- ▶ Water, electric and gas meters
- ▶ Fluid level detection

DIMENSIONS

in Millimeters (Inches)

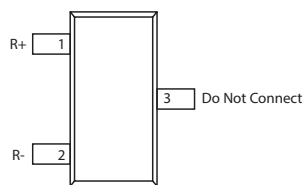
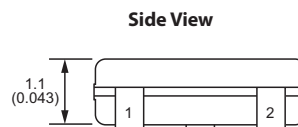
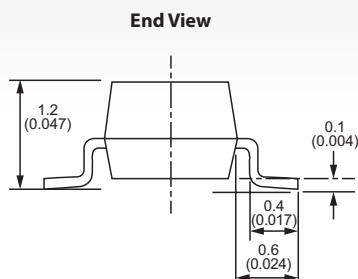
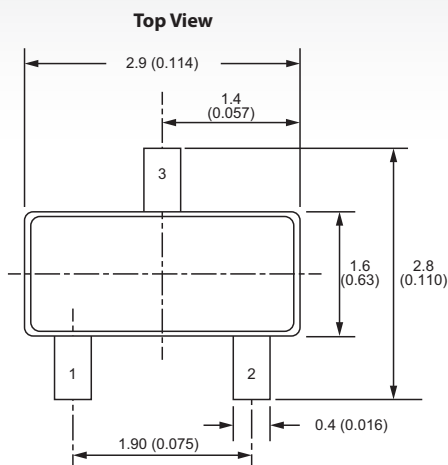

Ordering Information

Part Number	RR110-A X 1 1-0 0	Package	0 - SOT-23
Model Number		Special Feature	0 - N/A
Magnetoresistance (kΩ)		Sensitivity Pattern	1 = Unipolar
A: 65kΩ @ 0 G, 40kΩ @ 100 G			
Temp Rating (°C)	1 - Industrial (-40-85)		
Feature	1 - Default Value		

rev. 12152016

REDROCK™ RR110 TMR ANALOG SENSOR

REDROCK™		RR110		
Parameters ¹	Units	Min	Typ	Max
OPERATING CHARACTERISTICS²				
Resistance @0 Gauss	kΩ		65	
Resistance @100 Gauss	kΩ		40	
Response Time	ns		600	
ELECTRICAL CHARACTERISTICS				
Supply Voltage	V _{cc}			15
Operating Current ⁴	mA			1
ABSOLUTE ENVIRONMENTAL RATINGS				
Operating Temperature: Industrial	°C	-40		85
Storage Temperature	°C	-55		150
Soldering Temperature (3 cycles of 1 min.)	°C			260
Operating Magnetic Field	G			100
ESD Level (HBM) ³	V			N/A

Notes:

- Contact factory for more information on additional product offerings.
- All characteristics as measured at 25°C
- ESD PRECAUTIONS MUST BE USED WHEN HANDLING.**
- The RR110 sensor may be operated at any DC current up to 1 mA provided that the voltage developed across the sensor is sufficient for reliable detection.

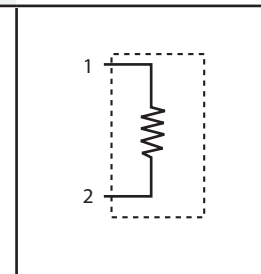

MAGNETIC SENSITIVITY TRANSFER CURVE

The magnetic sensitivity transfer curve illustrates the characteristic behavior of an analog TMR sensor's resistance change as the strength of an applied magnetic field changes. The magnet approach curve (red line) shows the change in resistance as the strength of an applied magnetic field increases. The magnet recede curve (blue dashed line) shows the change in resistance as the strength of an applied magnetic field decreases. Alternatively, you can think of the resistance going down the red slope as a magnet approaches the sensor, and going up the blue dashed slope as the magnet moves further away from the sensor.

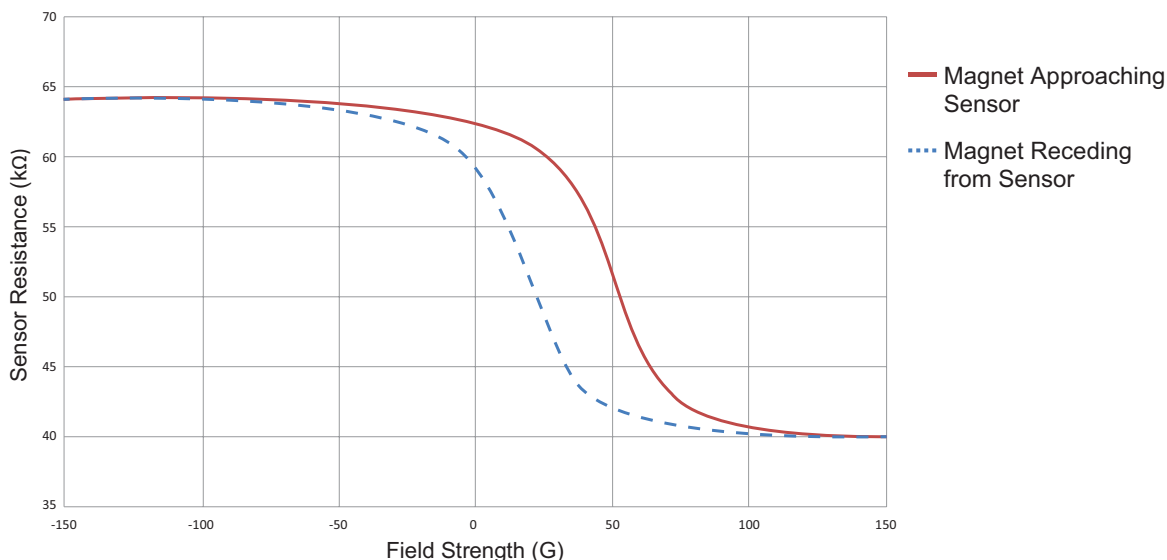

REDROCK™ RR120 TMR DIGITAL SENSOR



RedRock™ RR120 TMR Digital Sensor

The RedRock 120 Series is an integrated digital magnetic sensor ideal for use in medical, industrial, automotive and consumer switching applications. Based on patented Tunneling Magnetoresistance (TMR) technology with CMOS process, the RR120 Series can function even in low magnetic fields with large air gaps. The RR120 Series provides high sensitivity with low power consumption in a small footprint package.

Features

- ▶ High sensitivity
- ▶ Stable temperature performance
- ▶ Resistant to mechanical stress
- ▶ Low power consumption
- ▶ High frequency performance
- ▶ Logic output for design flexibility
- ▶ REACH Compliant
- ▶ RoHS Compliant

IDEAL APPLICATIONS

- ▶ Door or lid closure detection
- ▶ Smart phones, tablets and laptops
- ▶ Bare glass reed switch replacement
- ▶ Motor controllers
- ▶ Proximity detection
- ▶ Open-close detection
- ▶ Water, electric and gas meters
- ▶ Fluid level detection
- ▶ “Wake-Up” functionality

DIMENSIONS

in Millimeters (Inches)

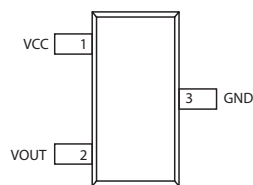
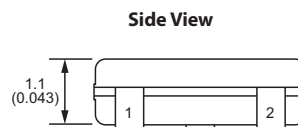
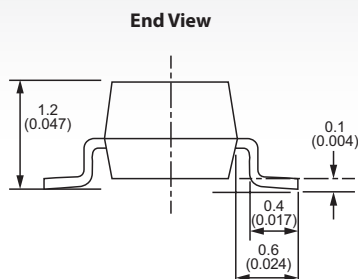
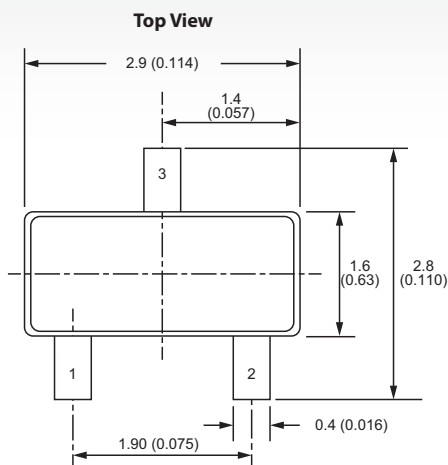

Ordering Information

Part Number	RR120-A X 1 X-X 0	Package	0 - SOT-23
Model Number		Special Feature	0 - N/A
Magnetic Sensitivity (G)	A - Op = 30 Rel = 15	Sensitivity Pattern	0 = Omnipolar 1 = Unipolar
Temp Rating (°C)	1 - Industrial (-40-85)		
Power Rating	1 - Default Value		

rev. 12152016

REDROCK™ RR120 TMR DIGITAL SENSOR

REDROCK™		RR120		
Parameters	Units	Min	Typ	Max
OPERATING CHARACTERISTICS¹				
Operate Sensitivity	G	20	30	40
Release Sensitivity	G	8	15	30
Hysteresis	%		50	
Operate Time	ms		30	
Release Time	ms		30	
ELECTRICAL CHARACTERISTICS¹				
Supply Voltage (V _{cc})	V	2.7	3.0	3.6
Average Current Drain	nA		350	400
Output Voltage (High) ² (V _{outh})	V		2.7 V	
Output Voltage (Low) ² (V _{outl})	V		0.2 V	
ABSOLUTE ENVIRONMENTAL RATINGS				
Operating Temperature: Industrial	°C	-40		85
Storage Temperature	°C	-55		150
Soldering Temperature (3 cycles, 1 min.)	°C			260
Operating Magnetic Field	G			100
ESD Level (HBM)	V			4000

Notes:

rev. 12022016

1. All characteristics as measured at 25°C
2. See "Magnetic Field vs. Output Status" (at right) for more details.

SENSOR POLARITY DIAGRAM

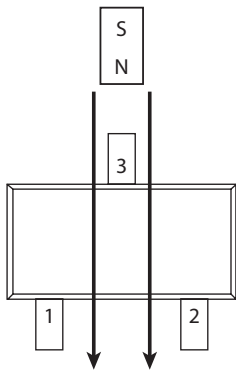

RR120 DIGITAL FUNCTION BLOCK DIAGRAM

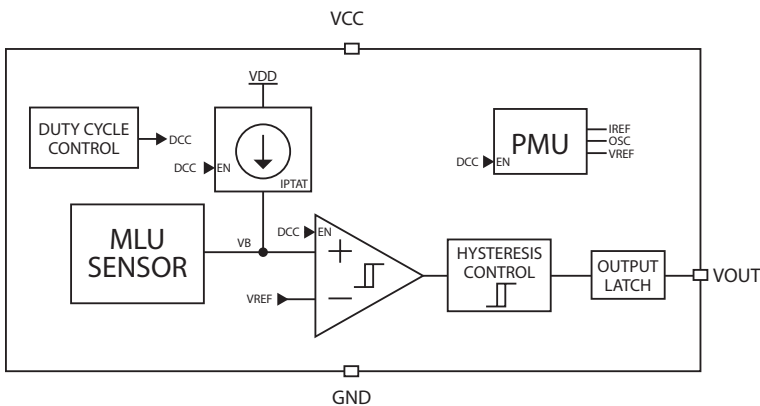

MAGNETIC FIELD vs. OUTPUT STATUS

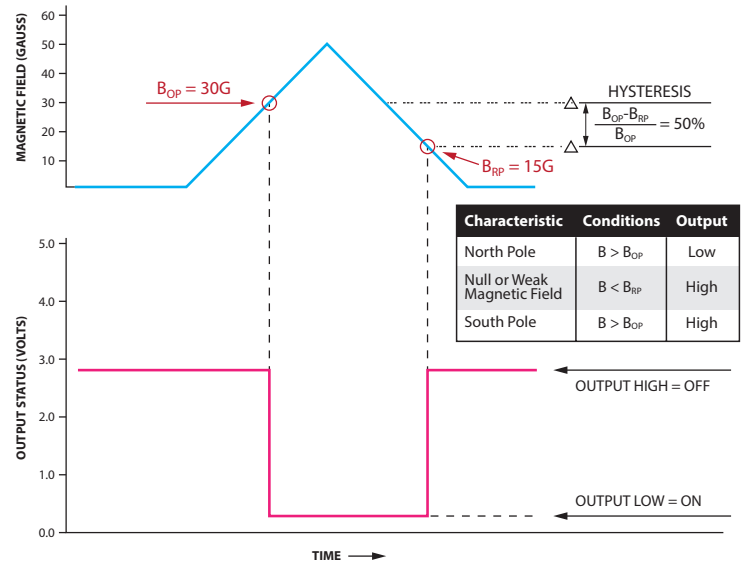

MLU SENSOR LOCATION DIAGRAM

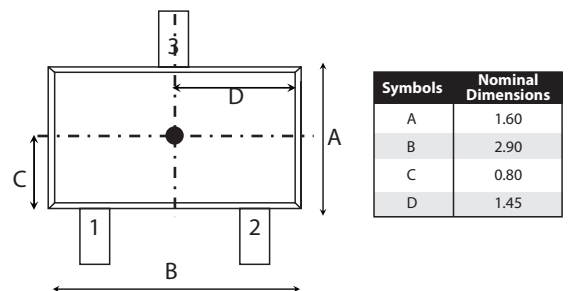

rev. 12152016

REDROCK™ RR130 TMR DIGITAL SWITCH



RedRock™ RR130 TMR Digital Switch

The RedRock 130 Series is an integrated digital magnetic switch ideal for use in medical, industrial, automotive and consumer switching applications. It is based on patented Tunneling Magnetoresistance (TMR) technology with integrated CMOS process. The RR130 Series can operate in low magnetic fields with large air gaps. The open drain output can interface with a system voltage up to 6V for added design flexibility. The RR130 Series provides high sensitivity with low power consumption in a small footprint package.

Features

- ▶ High sensitivity
- ▶ Stable temperature performance
- ▶ Resistant to mechanical stress
- ▶ Low power consumption
- ▶ High frequency performance
- ▶ Open drain MOSFET for design flexibility
- ▶ REACH Compliant
- ▶ RoHS Compliant

IDEAL APPLICATIONS

- ▶ Door or lid closure detection
- ▶ Smart phones, tablets and laptops
- ▶ Bare glass reed switch replacement
- ▶ Motor controllers
- ▶ Proximity detection
- ▶ Power switch or open-close detection
- ▶ Water, electric and gas meters
- ▶ Fluid level detection
- ▶ “Wake-Up” functionality

DIMENSIONS

in Millimeters (Inches)

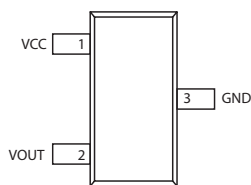
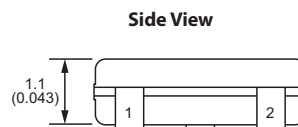
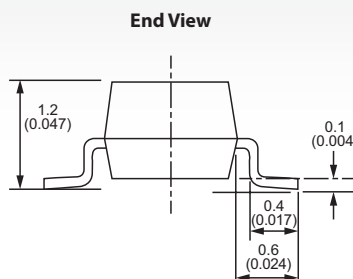
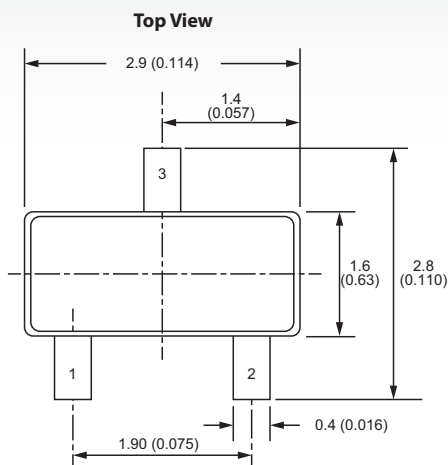

Ordering Information

Part Number	RR130-A X 1 X-X 0	Package	0 - SOT-23
Model Number		Special Feature	0 - N/A
Magnetic Sensitivity (G)	A - Op = 30 Rel = 15	Sensitivity Pattern	0 = Omnipolar 1 = Unipolar
Temp Rating (°C)	1 - Industrial (-40-185)		
Power Rating	1 - Default Value		

rev. 12152016

REDROCK™ RR130 TMR DIGITAL SWITCH

REDROCK™		RR130		
Parameters	Units	Min	Typ	Max
OPERATING CHARACTERISTICS¹				
Operate Sensitivity	G	20	30	40
Release Sensitivity	G	8	15	30
Hysteresis	%		50	
Operate Time	ms		30	
Release Time	ms		30	
ELECTRICAL CHARACTERISTICS¹				
Supply Voltage ² (V _{CC})	V	2.7	3.0	3.6
Average Current Drain	nA		350	400
System Voltage ² (V _{sys})	V			6
System Current ² (I _{sys})	mA			15
ABSOLUTE ENVIRONMENTAL RATINGS				
Operating Temperature: Industrial	°C	-40		85
Storage Temperature	°C	-55		150
Soldering Temperature	°C			260
Max. Exposed Magnetic Field	G			100
ESD Level (HBM)	V			4000

Notes:

1. All characteristics as measured at 25°C
2. See "Application Circuit" for more information.

APPLICATION CIRCUIT

RR130

Open Drain Output Application Circuit

With the open drain output, the system voltage can range up to 6V. Please keep in mind the supply to the RR130 must remain at 3V. A decoupling capacitor between the supply voltage and ground is recommended with placement close to the magnetic sensor. A typical capacitor value of 0.1 uF will suffice.

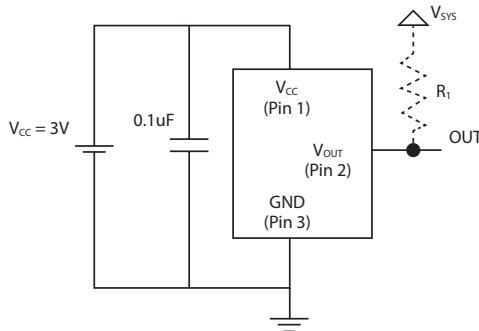

MAGNETIC FIELD vs. OUTPUT STATUS

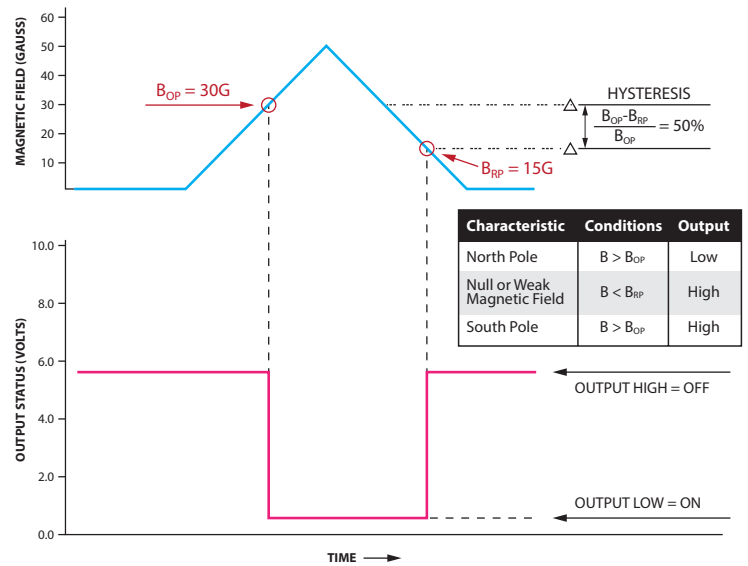

SENSOR POLARITY DIAGRAM

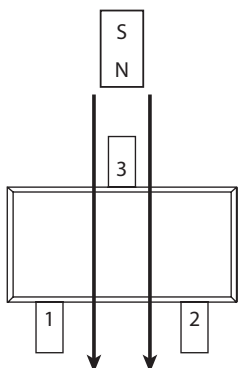

MLU SENSOR LOCATION DIAGRAM

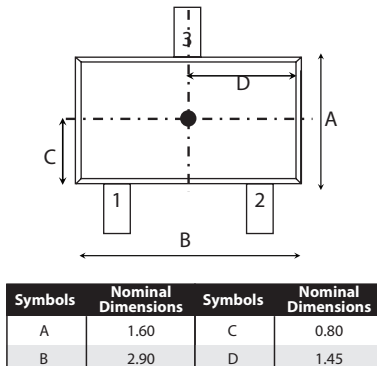

RR130 DIGITAL FUNCTION BLOCK DIAGRAM

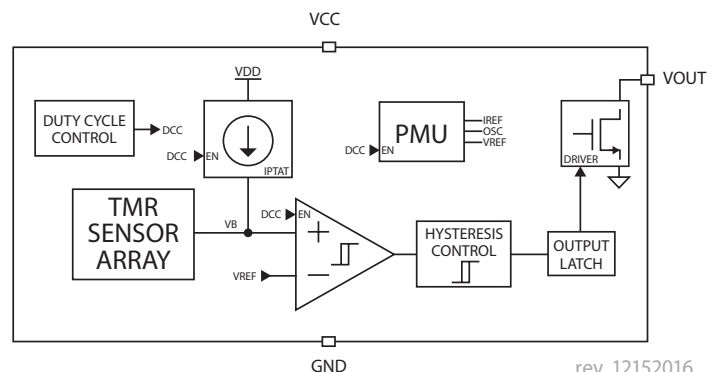

rev. 12152016

TMR TECHNICAL & APPLICATIONS INFORMATION

TMR SENSOR & SWITCH PACKAGING

Standard packaging is Tape & Reel containing 3,000 pieces. Below is a chart of Tape & Reel dimensions for standard TMR products.

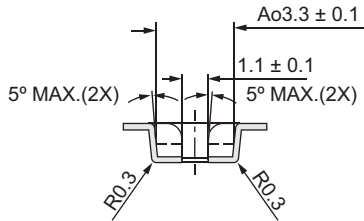
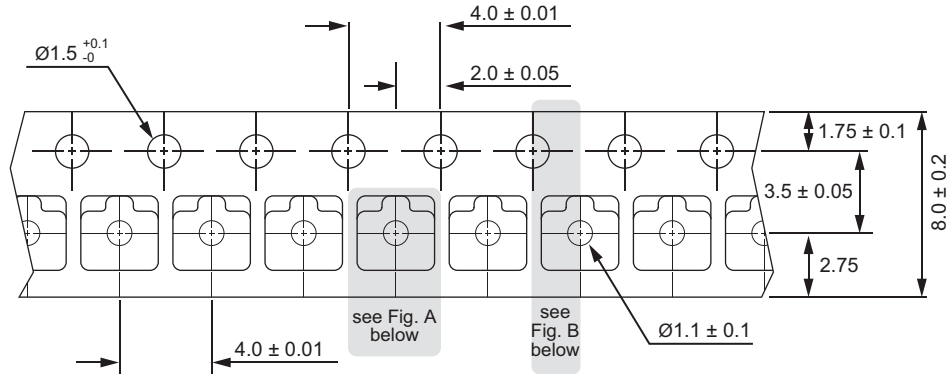

Fig. A

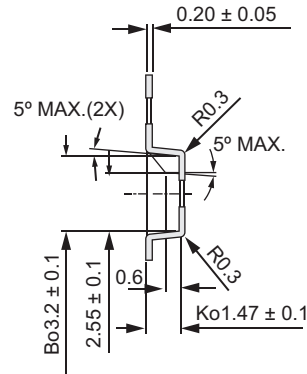
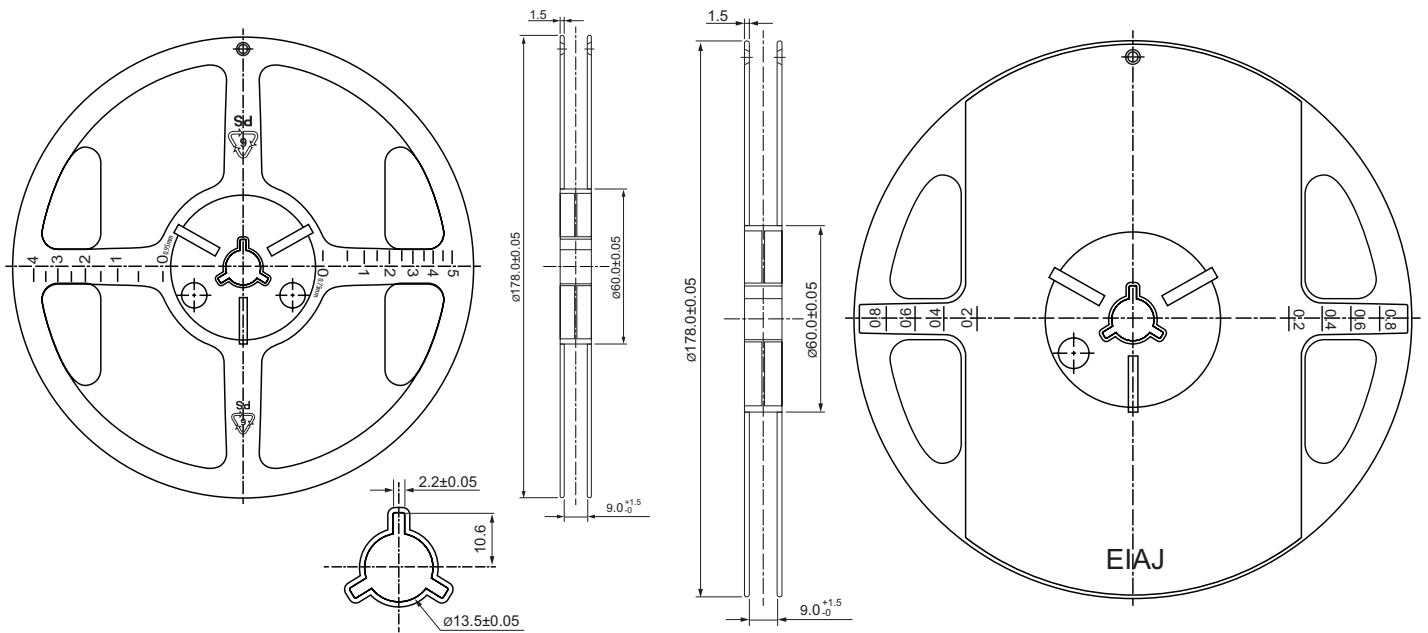
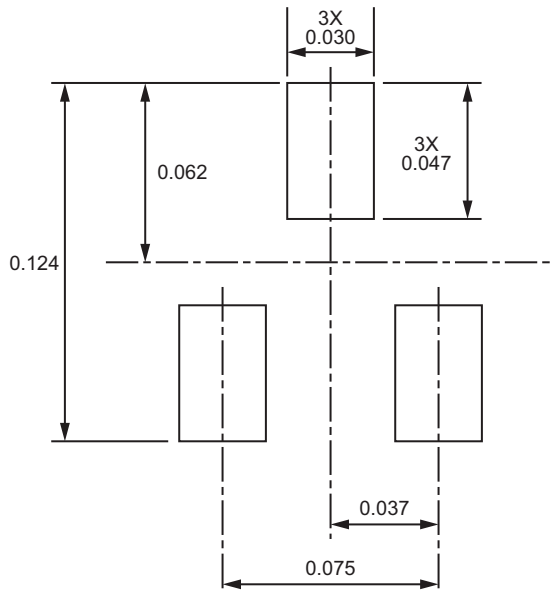

Fig. B



SUGGESTED SOLDER PAD LAYOUT



(Units in mm)

SUGGESTED REFLOW PROFILE

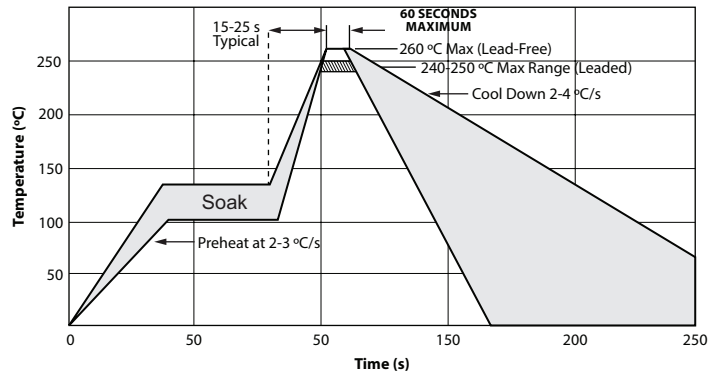

Notes:

1. Fully compatible with standard no-lead solder profile, 260 °C for 1 minute max (3 cycles max)
2. Profile shown as example. Users are advised to develop their own board-level profile
3. Temperature tolerance: +0 °C, as measured at any point on the package or leads
4. MSL listed on main specification page compatible with J-STD-020 or equiv.

GLOSSARY OF TERMS

Hysteresis: Hysteresis refers to the difference between two points of interest for a particular device. For digital sensors and switches, it represents the difference between the operate sensitivity and the release sensitivity, expressed either as an absolute value ($B_{OP} - B_{RP}$) or the % difference $(B_{OP} - B_{RP})/B_{OP}$. For an analog sensor, the hysteresis is the difference between the “magnet approach curve” and the “magnet recede curve.”

Magnet Approach Curve: The magnet approach curve is the characteristic change in resistance of an analog TMR sensor as an applied magnetic field approaches the sensor, typically plotted as a function of the magnetic field strength.

Magnet Recede Curve: The magnet recede curve is the characteristic change in resistance of an analog TMR sensor as an applied magnetic field recedes from the sensor, typically plotted as a function of the magnetic field strength.

Magnetoresistance: Magnetoresistance is a phenomenon wherein the electrical resistance of certain materials changes when exposed to an externally-applied magnetic field.

Magnetic Transfer Curve: The magnetic transfer curve defines the characteristic behavior of an analog TMR sensor by combining both the magnet approach curve and the magnet receive curve together.

Magnetic Tunnel Junction: A magnetic tunnel junction is a thin film structure consisting of two magnetic layers separated by a thin insulator. Because the insulating layer is thin enough (typically a few nanometers), electrons can tunnel from one magnetic layer into the other.

Operate Sensitivity: The operate sensitivity defines the upper limit of the strength of an applied magnetic field that a digital TMR sensor or switch must operate.

Operate Time: The operate time is the difference, in time, between the application of a magnetic field and the output response of the device. In an analog sensor, the response is a change in output resistance. In a digital sensor, the response is a change in state of the electrical output.

Release Sensitivity: The release sensitivity defines the lower limit of the strength of an applied magnetic field that a digital TMR sensor or switch must release.

Release Time: The release time is the difference, in time, between the removal of an applied magnetic field and the output response of the device. In an analog sensor, the response is a change in output resistance. In a digital sensor, the response is a change in state of the electrical output.

Tunnel Magnetoresistance (TMR): Tunnel Magnetoresistance is the magnetoresistive effect that occurs in a magnetic tunnel junction.

MAGNETIC SENSITIVITY MAPS

Magnetic sensitivity maps show the operate and release loci in three-dimensional space when a magnet is presented to a magnetically operated switch or sensor. The absolute operate and release distances between the magnet and the sensor will vary depending on the sensitivity of the switch and the strength of the magnet. However, the

shape and direction of the operate loci stay relatively constant except for cases where the magnet is physically much larger than the sensor. These plots were generated using a 2mm³ cubic shaped NdFeB N52 magnet with its North pole presented to the ground pin and a South pole presented to the opposite side.

RR120/RR130 Magnetic Sensitivity Pattern, perspective view

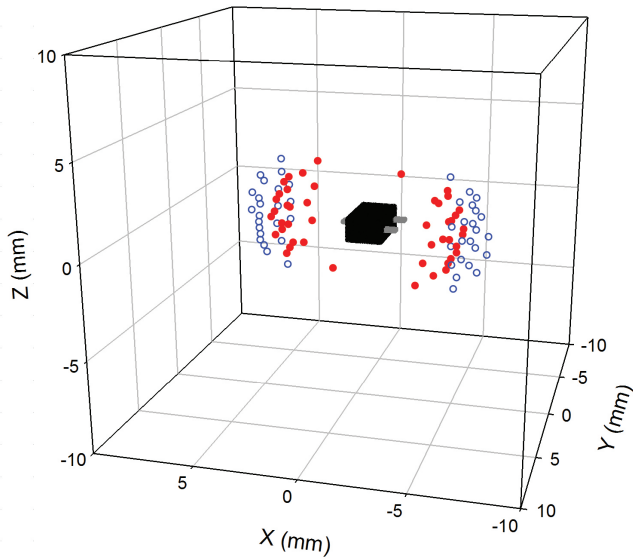

RR120/RR130 Magnetic Sensitivity Pattern, YZ plane

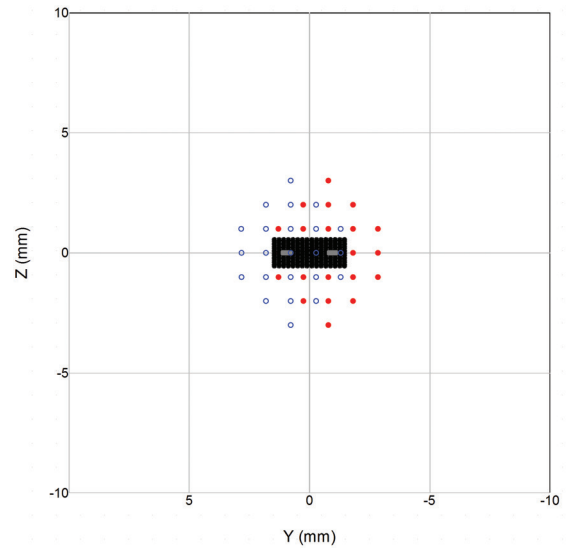

- Operate Points
- Release Points

RR120/RR130 Magnetic Sensitivity Pattern, XY plane

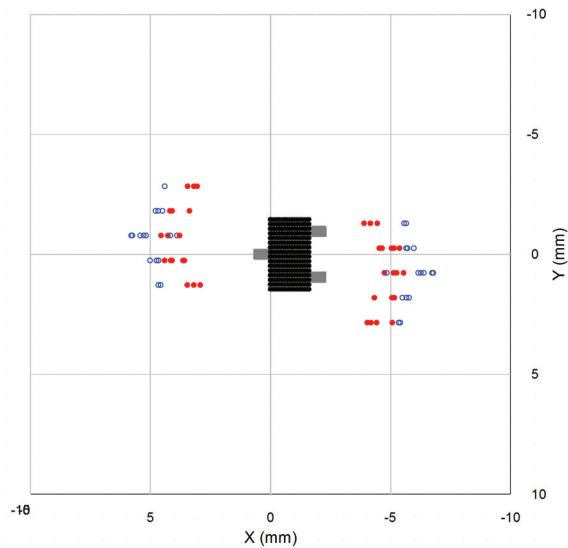

RR120/RR130 Magnetic Sensitivity Pattern, XZ plane

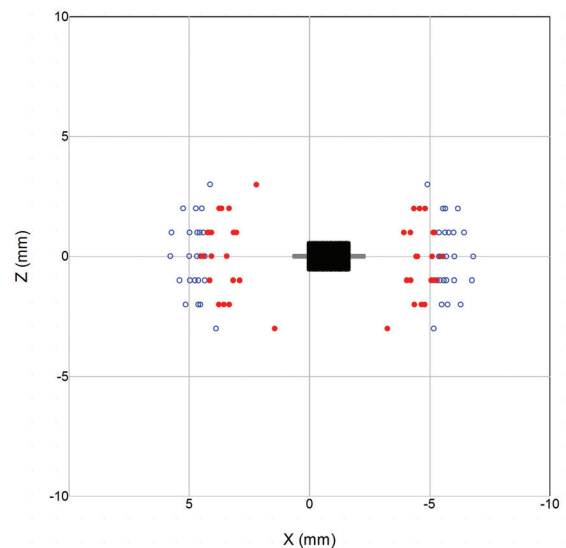



66 Whitecap Drive
North Kingstown, RI 02852
401-943-2686 • Fax: 401-942-0920
www.cotorelay.com • redrock@cotorelay.com