

## Datasheet

Green-red LED status indicator

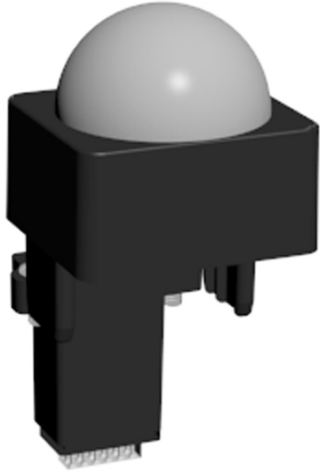

Model	Light Colors	Connector
EZLSA-K30LGR (patent pending)	Red and green	Integral connector attaches to the end cap of a cascadable EZ-SCREEN LS receiver with two Phillips-head screws

## Specifications

### Supply Voltage and Current

24 V dc  $\pm 15\%$ ; 15 mA typical; 40 mA maximum  
 Powered by the EZ-SCREEN, only one color is on at a time

### Connections

Integral connector for use with EZ-SCREEN LS only

### Indicators

	Solid	Flashing	Off
Green LED	OSSDs ON		No power
Red LED	OSSDs OFF	Lockout (OSSDs OFF)	No power

Entire translucent diffuser or dome provides 360° indication

### Construction

30 mm translucent UV stabilized polycarbonate dome; polycarbonate housing

### Environmental Rating

IEC IP65; IEC IP67

### Operating Conditions

-20 °C to +55 °C (-4 °F to +131°F)  
 95% maximum relative humidity (non-condensing)

## Dimensions

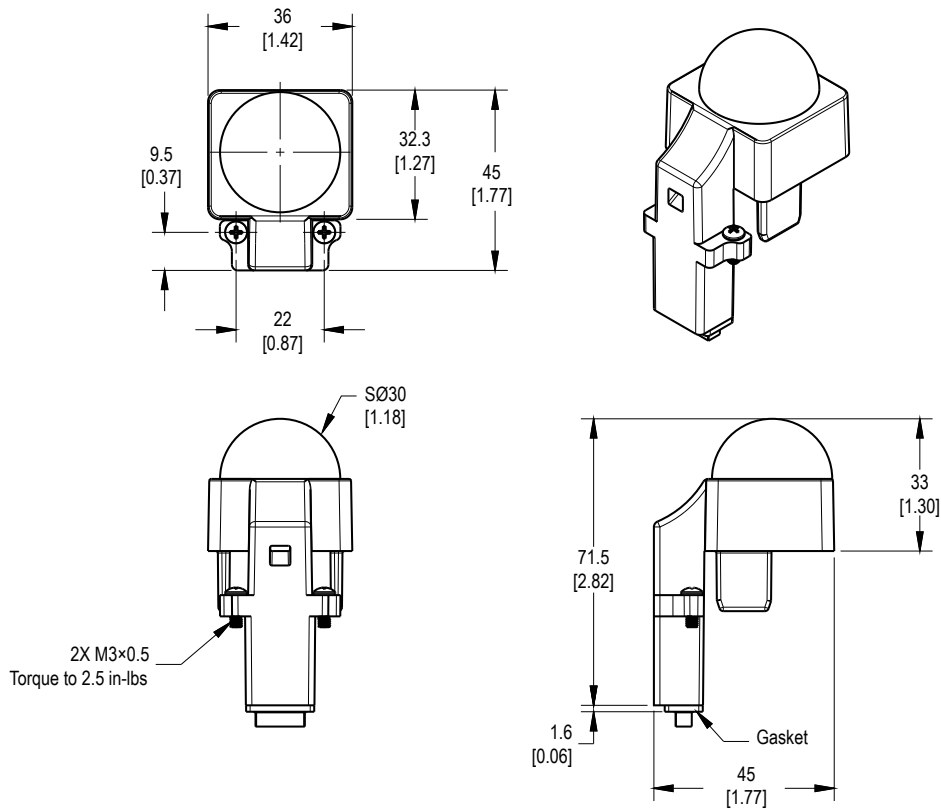

## Banner Engineering Corp. Limited Warranty

Banner Engineering Corp. warrants its products to be free from defects in material and workmanship for one year following the date of shipment. Banner Engineering Corp. will repair or replace, free of charge, any product of its manufacture which, at the time it is returned to the factory, is found to have been defective during the warranty period. This warranty does not cover damage or liability for misuse, abuse, or the improper application or installation of the Banner product.

THIS LIMITED WARRANTY IS EXCLUSIVE AND IN LIEU OF ALL OTHER WARRANTIES WHETHER EXPRESS OR IMPLIED (INCLUDING, WITHOUT LIMITATION, ANY WARRANTY OF MERCHANTABILITY OR FITNESS FOR A PARTICULAR PURPOSE), AND WHETHER ARISING UNDER COURSE OF PERFORMANCE, COURSE OF DEALING OR TRADE USAGE.

This Warranty is exclusive and limited to repair or, at the discretion of Banner Engineering Corp., replacement. IN NO EVENT SHALL BANNER ENGINEERING CORP. BE LIABLE TO BUYER OR ANY OTHER PERSON OR ENTITY FOR ANY EXTRA COSTS, EXPENSES, LOSSES, LOSS OF PROFITS, OR ANY INCIDENTAL, CONSEQUENTIAL OR SPECIAL DAMAGES RESULTING FROM ANY PRODUCT DEFECT OR FROM THE USE OR INABILITY TO USE THE PRODUCT, WHETHER ARISING IN CONTRACT OR WARRANTY, STATUTE, TORT, STRICT LIABILITY, NEGLIGENCE, OR OTHERWISE.

Banner Engineering Corp. reserves the right to change, modify or improve the design of the product without assuming any obligations or liabilities relating to any product previously manufactured by Banner Engineering Corp.

