

THIS DRAWING IS UNPUBLISHED. RELEASED FOR PUBLICATION
 © COPYRIGHT 19 BY AMP INCORPORATED. ALL INTERNATIONAL RIGHTS RESERVED.

LOC	DIST	P	F	ZONE	LTR	REVISIONS	DATE	APPD
G	14					C REV & REDRAWN PER 0720-0040-93	3-24-93	APPD

METRIC
 DIMENSIONS LISTED IN mm [INCHES]

AMP WIRE RANGE	UL Listed
6HD AWG SOLID OR STRANDED	6HD AWG STRANDED
LR7189 Certified	MILITARY P/N AND CLASS
6HD AWG SOLID OR STRANDED	NOT APPLICABLE

△ STAMP AMP 6HDW* APPROX AS SHOWN

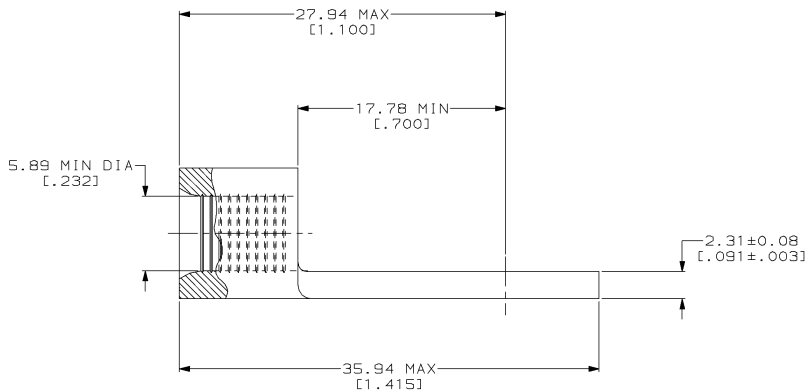
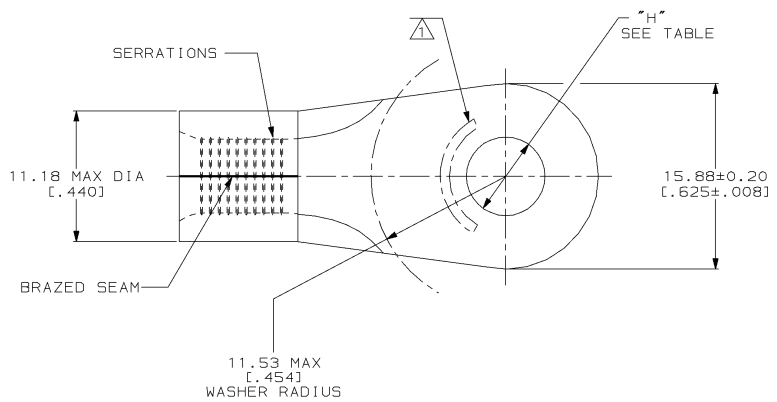

3/8	9.91±0.13 DIA [.390±.005]	1-331417-1
1/4	6.73±0.13 DIA [.265±.005]	331417
STUD SIZE	"H"	PART NO

AMP INCORPORATED
CUSTOMER SERVICE SYSTEMS

FOR ADDITIONAL PRODUCT INFORMATION OR COPIES OF DRAWINGS AND TECHNICAL DOCUMENTS
 PRODUCT INFORMATION CENTER
 1-800-522-6752

FOR APPLICATION TOOLING INFORMATION
 TOOLING ASSISTANCE CENTER
 1-800-722-1111

FOR ORDER ENTRY
 1-800-526-5142

MAX RECOMMENDED OPERATING TEMPERATURE:
 170°C MAX

VOLTAGE RATING:
 NOT APPLICABLE

WIRE CROSS SECTIONAL AREA RANGE:
 10.5-16.8MM² [20,800-33,100] CIR MILS
 SOLID OR STRANDED

THIS DRAWING IS A CONTROLLED DOCUMENT FOR AMP INCORPORATED. IT IS SUBJECT TO CHANGE AND THE CONTROLLING ENGINEERING ORGANIZATION SHOULD BE CONTACTED FOR THE LATEST REVISION.

DO NOT SCALE PRINT.
 UNLESS SPECIFIED DIMENSIONS IN mm [INCHES]
 TOLERANCES ON:
 2 PLC DEC ± -
 3 PLC DEC ± -
 ANGLES ± -

MATERIAL
 COPPER PER
 ASTM B-152
 ANNEALED

FINISH
 T1N PLATE
 0.00254 [0.000100] MIN
 THK PER MIL-T-10727

DR 3-24-93
 TA BRINKMAN

CHK 3-24-93
 DA PATTERSON

APPD 3-24-93
 DE MILLER

APPD 3-24-93
 JL MECKLEY

APPLICATION SPEC
 -

WEIGHT
 -

AMP AMP Incorporated
 Harrisburg, PA 17105-3608

NAME
**TERMINAL, RING TONGUE,
 HEAVY DUTY, SOLISTRAND™**

SIZE
 © 00779

DRAWING NO
 ©-331417

SCALE 4:1

SHEET 1 OF 1

AMP 1471-6 REV 3-92
 10_SEP_1993 09:53:04 AMP26463 <U5128A>DEPT1123>DWG1123>U_SOL1STRAND>U_INL.NE

CUSTOMER DRAWING