

1. INTRODUCTION

This instruction sheet covers the installation and operation of the AGASTAT* 7000 Series 4-Pole Timing Relays (Models 7014 and 7024). Read these instructions thoroughly before installing the relay.

NOTE Dimensions in this instruction sheet are in millimeters [with inches in brackets]. Figures are not drawn to scale.

2. DESCRIPTION (Figure 1)

Each relay is a precise timing instrument which balances pneumatic, electrical, and mechanical forces using a minimum of moving parts. When satisfactory performance cannot be restored, the unit should be returned to TE Connectivity for repair.

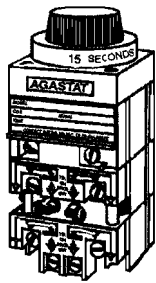

4-Pole Timing Relay (Typ)

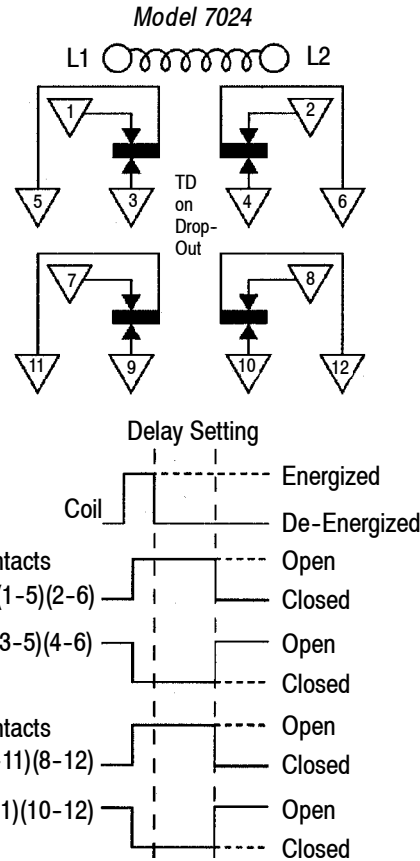
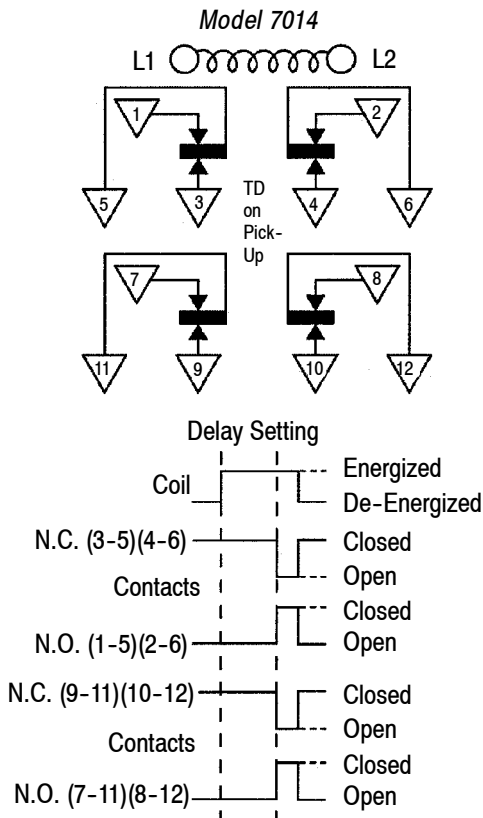

LINEAR TIMING RANGES		
TIME RANGE CODE	MODEL 7014●	MODEL 7024
A	0.2 to 2 Seconds	0.1 to 1 Second
B	0.7 to 7 Seconds	0.5 to 5 Seconds
C	2 to 20 Seconds	1.5 to 15 Seconds
D	10 to 100 Seconds	5 to 50 Seconds
E	30 to 300 Seconds	20 to 200 Seconds
F	1.5 to 15 Minutes	1 to 10 Minutes
H	3 to 30 Minutes	3 to 30 Minutes
I	Not Available	6 to 60 Minutes
J	Not Available	3 to 120 Cycles
K	Not Available	1 to 300 Cycles

● Model 7014 is available with letter calibrated dials only. The upper end of the time ranges in this model may be twice the values shown.

Figure 1 (cont'd)

AC COIL UNITS			DC COIL UNITS	
CODE LETTER	RATED VOLTAGE AT 60 Hz	RATED VOLTAGE AT 50 Hz	CODE LETTER	RATED VOLTAGE
A	120	110	M	28
B	240	220	N	48
C	480	-	O	24
D	550	-	P	120
E	24	-	Q	12
F	-	127	R	60
G	-	240	S	250
H	12	-	T	550
I	6	-	U	16
J	208	-	V	32
K	Dual Voltage Coil (Combines A and B)		W	96
			Y	6
			Z	220

AC Specials L1, L2, etc. DC Specials X1, X2, etc.

Operational voltage range 90% to 120% for AC units; 85% to 120% for DC units.

All units draw approximately 8 watts power at rated voltage.

Minimum operating voltages are based on vertically mounted Model 7014 (on-delay) units.

AC units drop out at approximately 50% of rated voltage. DC units drop out at approximately 40% of rated voltage.

All units may be operated on intermittent duty cycle at voltages 10% above the listed maximums. (Intermittent duty - maximum 50% duty cycle and 30 minutes "on" time.)

Coils are rated 6 Vac through 550 Vac.

CONTACT RATINGS (Contact Capacity in Amperes - Resistive Loads)		
CONTACT VOLTAGE	MINIMUM 100,000 OPERATIONS	MINIMUM 1,000,000 OPERATIONS
30 Vdc	15.0	7.0
110 Vdc	1.0	0.5
120 Vac 60 Hz	20.0	15.0
240 Vac 60 Hz	20.0	15.0
480 Vac 60 Hz	12.0	10.0

Inductive and capacitive loads should not have inrush currents that exceed five times normal operating load.

Contact ratings are listed under the Underwriters Laboratories Inc. Component Recognition Program for 100,000 operations:

- 10 A Resistive, 240 Vac (per pole)
- 1/4 Horsepower, 120 Vac/240Vac (per pole)
- 15 A, 30 Vdc (per pole)
- 5 A, General Purpose, 600 Vac

Total load must not exceed twice the above listings per pole rating. Continuous duty rating is 25 amperes any voltage, any load.

Figure 1 (end)

3. MOUNTING INSTRUCTIONS (Figure 2)

Normal mounting of the relay is in a vertical position, from the back of the panel. Four No. 8-32 tapped holes are provided in the back plate.

CAUTION Mounting screws should not project more than 3.63 mm [5/32 in.] into the back of the unit, to prevent internal damage.

A bracket and required screws are supplied with each unit for mounting the unit from the front. The bracket extends approximately 9.52 mm [3/8 in.] from each side of the unit.

NOTE Horizontal operation is not recommended.

Models 7014 and 7024 (Mounting Dimensions)

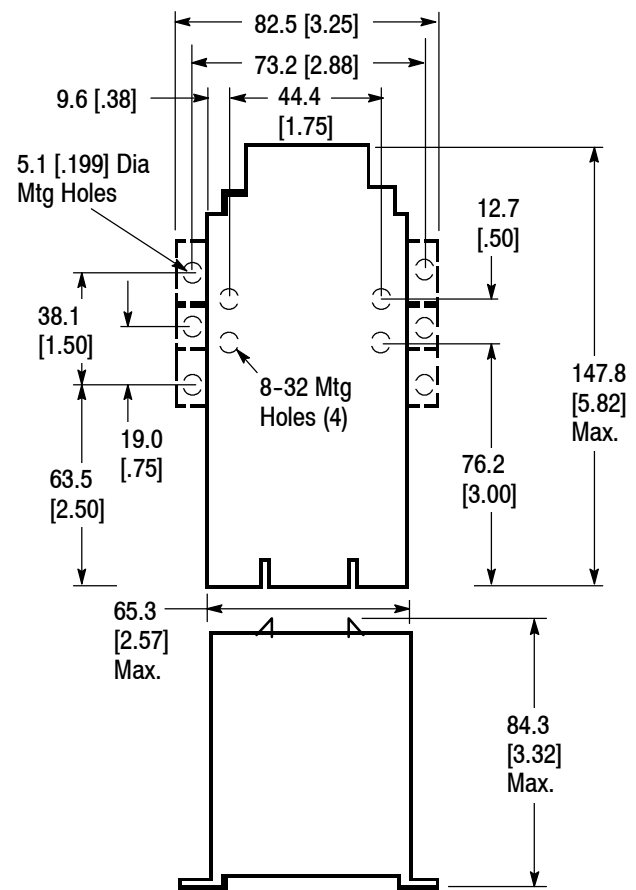

Figure 2

4. QUALIFICATIONS

The 7000 Series Timing Relays are Listed by Underwriters Laboratories Inc. (UL) in File E15631. and Certified to CSA International in File LR29186.

5. REVISION SUMMARY

- Updated document to corporate requirements
- New logo

Mouser Electronics

Authorized Distributor

Click to View Pricing, Inventory, Delivery & Lifecycle Information:

TE Connectivity:

[7012PB](#) [7012PF](#) [7012PC](#) [7012OC](#) [7012PJL](#) [7012PDT](#) [7022MH](#) [7012ACL](#) [7012ACLL](#) [7012ADL](#) [7012AI](#)
[7012BH](#) [7012L8DN](#) [7012PA](#) [7012PD](#) [7012PE](#) [7012PH](#) [7012PK](#) [7012SC](#) [7014AB](#) [7014AC](#) [7014PD](#) [7022L8CN](#)
[7012AC](#) [7012AK](#) [7012AA](#) [7012AB](#) [7012AE](#) [7012BD](#) [7012NC](#) [7012PJ](#) [7012L8FN](#) [7022L8HN](#) [7012QC](#)
[7012L8AI2LLSN](#) [7022RHA2I](#) [7024RKIV](#) [7012X3A](#) [7014RHA2I](#) [7012L8CN](#) [7022RFA2I](#)