

SECTION A-A  
SCALE 4 : 1

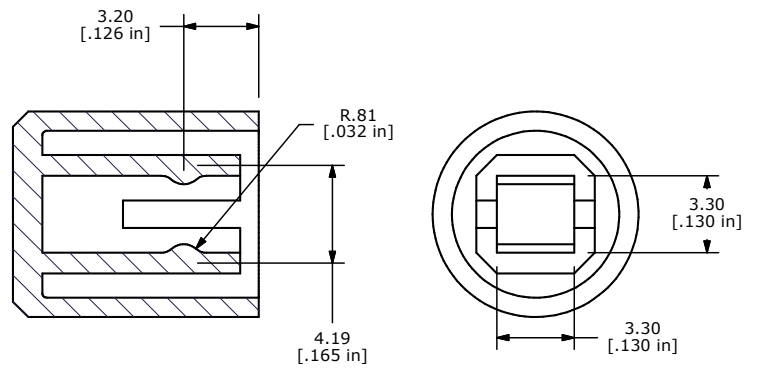
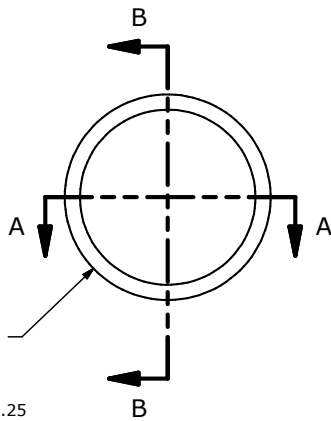
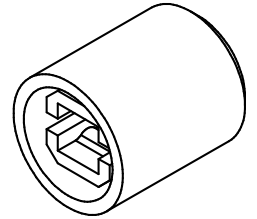

SECTION B-B  
SCALE 4 : 1

NOTES:

1. ALL DIMENSIONS IN MM[INCH]
2. GENERAL TOLERANCE: X.XX $\pm$ 0.25
- ▲3. MATERIAL: ABS UL94HB
- ▲4. COLOR: CHROME
5. ▲ DENOTES CRITICAL PARAMETER
6. 2002/95/EC (ROHS) COMPLIANT

C	17669	CHANGED TOLERANCE	9/13/07	BF
B	17594	CHANGED DETENT RIB PLACEMENT	8/27/07	BF
A	15210	NEW RELEASE	8/29/05	PH
REV	PCR NO	DESCRIPTION	DATE	BY

THE INFORMATION CONTAINED IN THIS DOCUMENT IS PROPRIETARY TO E-SWITCH AND IS NOT TO BE COPIED OR TRANSFERRED



TITLE TAGCHR

SCALE 4:1	DATE 9/13/2007	DR BF	DWG T041605	REV C
-----------	----------------	-------	-------------	-------