



*New*

COMPACT SIZE • DIGITAL PRESSURE SENSOR

# DP4 SERIES

The new shape of digital pressure sensor

# New Design



# Ideal for panel-mounting!

New standard DP4 series model  
 – from the digital pressure sensor pioneer, **SUNX**.

First in the industry

## Light-weight, compact design

- ① A compact form specifically designed for mounting on an equipment panel. It only uses half the space of our conventional product and provides the lightest weight in the industry of just 30g (cables excluded).
- ② Even when you use more than one sensor at the same time, you can mount them closely in one hole to save both space and man-hours.

### When you mount four digital pressure sensors in a panel

Conventional products	DP4 series
Mounting hole 36 × 36mm holes, 4 Nos.	Mounting hole 37 × 77mm hole, 1 No.
Mounting area 12,000mm <sup>2</sup> approx.	Mounting area 3,200mm <sup>2</sup>



Mounting area ..... Reduced by 70%  
 Panel machining cost .. Substantially reduced

Easy-to-view  
 No.1

## Bright, easy to view two-color digital display

The digital display is a large, easy-to-view, and two-color digital display. It is also functions as an output indicator as it changes from green to red color when the output turns ON, enabling you confirm the output status at a glance.



Output OFF

Output ON



First in the industry Convenient

## Usable with a panel thickness of 1 to 6mm

Since the panel thickness can be from 1 to 6mm, the sensor can even be mounted on thick, resin-made panels.

First in the industry Convenient

## Supplied with a simple-to-mount panel mounting bracket

A panel mounting bracket is enclosed to enable simple mounting of the sensor onto the panel surface, thus contributing to the total cost reduction.



New idea Ecological Convenient

## Snap-fit connector is used for cable connection

The cable has a snap-fit connector for easy mounting and removal. The connector can be easily assembled by yourself.

Further, the connection by connector eliminates waste and is eco-friendly.

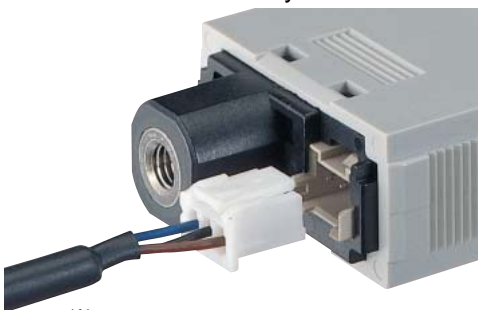

※Connector attached cable **CN-63-C2** (cable length: 2m) is also available.

### Due to connection by connector

- ① Waste is eliminated.
- ② Since only the cable is crimped separately, the sensor can be installed in the equipment beforehand.
- ③ Moreover, if the cable is prepared beforehand, you can immediately mount the sensor it is received.

First in the industry Convenient

## Can be mounted on a DIN rail

The sensor can be mounted even on a 35mm width DIN rail by using the optional DIN rail mounting bracket (**MS-DP-2**).

It can be mounted in a narrow space inside of your device.



Easy-to-use No.1 Convenient

## Flexible control with four output modes

### Hysteresis mode

The hysteresis of the output can be set, as desired, with the set values.

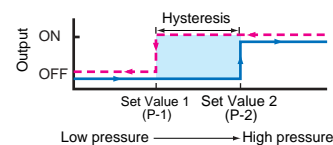

Note: The above figure is for the case when the output operation is set to NO (normally open).

### Window comparator mode

The output can be turned ON or OFF by a pressure within the set range.

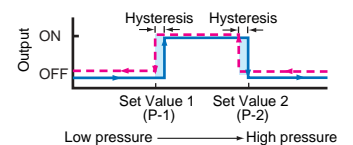

Note: The above figure is for the case when the output operation is set to NO (normally open).

### Automatic sensitivity setting mode

Using actual objects, if the pressure values for OK objects and NG objects are input, then the sensor automatically set to the optimum pressure value (mid-value).

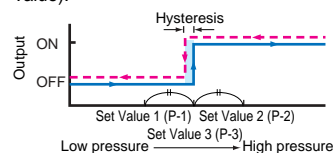

Note: The above figure is for the case when the output operation is set to NO (normally open).

### Forced output mode

The output is forcibly maintained in the OFF state in the sensing mode, irrespective of the set values.

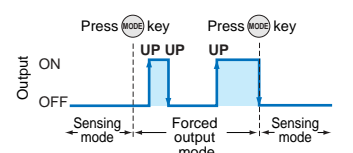

Note: The above figure is for the case when the output operation is set to NO (normally open).

No. 1  
in the industry

## High speed response of 2ms or less

The sensor has a high speed response of 2ms or less – the best in the industry.

In addition, the sensor has a chattering prevention function. This allows change-over of the response time so that fluctuation of the reference pressure generated during operation of the large-diameter cylinder and the ejector is not detected as an abnormal pressure.

### Response time

- 2ms
  - 16ms
  - 128ms
  - 512ms
- 4 steps  
change-over

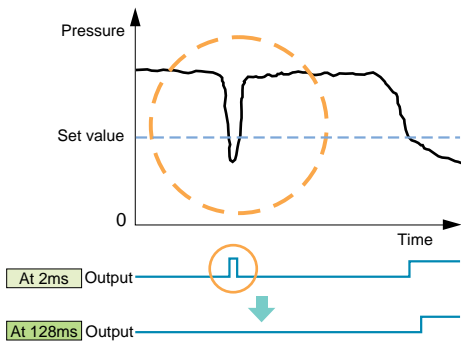

Convenient

## Change-over to analog bar display possible

The pressure changes can be indicated as a bar display. The analog bar color reflects the changes in the output. (The detected pressure value is displayed in steps of 14% F.S. approx.)

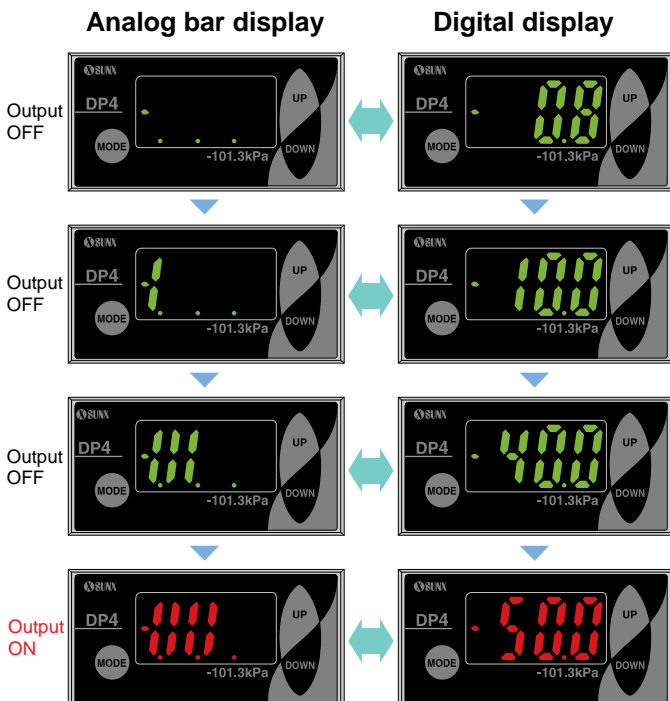

No. 1  
in the industry

Ecological

## Low current consumption

With a low consumption of 40mA of current, this sensor responds to the needs of our resource- and power-saving age.

Convenient

## ± 100kPa compound pressure type available

To serve a broad range of pressure needs, we offer ± 100.0kPa, compound pressure type, in addition to the 0 to 101.3kPa and 0 to 1.000MPa types.

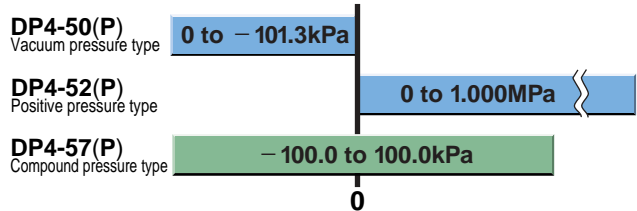

New idea

## Incorporated with the memory bank function

You can store two patterns of set values. Hence, the setup can be changed by a single touch.

## Selection from six pressure units

The pressure unit can be selected from six different systems to suit your requirement.

(The selectable pressure units differ with the sensor type. When the pressure unit is changed, the measured pressure value and the set values are automatically converted.)

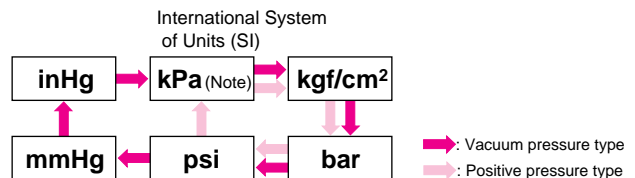

Note: 'MPa' in case of DP4-52(P) positive pressure type



## Global use

Two types of output, NPN and PNP, are available to allow use of the sensors anywhere in the world.

The sensor, of course, conforms to the CE marking EMC Directive.

Further, it has obtained UL recognition.

## APPLICATIONS

### Checking IC absorption

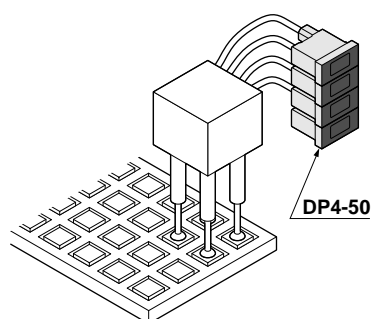

### Checking degree of vacuum for vacuum molding

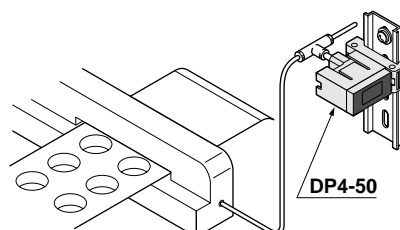

### Checking reference pressure of device

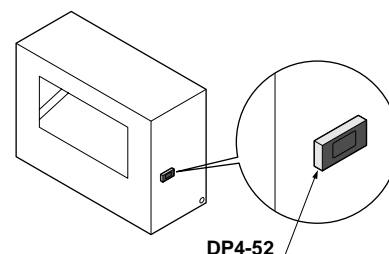

## ORDER GUIDE

Type	Appearance	Rated pressure range (Note)	Model No.	Pressure port	Output
Vacuum pressure -101kPa type		0 to -101.3kPa	DP4-50	M5 female thread	NPN open-collector transistor
			DP4-50P		PNP open-collector transistor
Positive pressure 1MPa type		0 to 1.000MPa	DP4-52		NPN open-collector transistor
			DP4-52P		PNP open-collector transistor
Compound pressure ±100kPa type		-100.0 to 100.0kPa	DP4-57		NPN open-collector transistor
			DP4-57P		PNP open-collector transistor

Note: The rated pressure range indicates the range for full product performance.

### Panel mounting bracket (accessory)

MS-DP-1

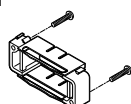

## OPTIONS

Designation	Model No.	Description	
Connector	CN-63	Set of 10 housings and 30 connector brackets	
Connector attached cable (Note)	CN-63-C2	Length: 2m	0.2mm <sup>2</sup> 3-core cabtyre cable with connector Cable outer diameter: $\phi$ 3.8mm
DIN rail mounting bracket	MS-DP-2	For installation to 35mm width DIN rail	

Note: 5m cable length type (CN-63-C5) is also available.

### Connector

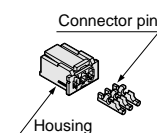

### Connector attached cable

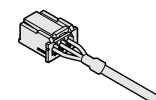

### DIN rail mounting bracket

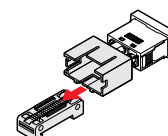



## SPECIFICATIONS

Item	Type Model No.	Vacuum pressure		Positive pressure		Compound pressure	
		- 101kPa type		1MPa type		± 100kPa type	
		NPN output <b>DP4-50</b>	PNP output <b>DP4-50P</b>	NPN output <b>DP4-52</b>	PNP output <b>DP4-52P</b>	NPN output <b>DP4-57</b>	PNP output <b>DP4-57P</b>
Type of pressure		Gauge pressure					
Rated pressure range		0 to - 101.3kPa		0 to 1.000MPa		- 100.0 to 100.0kPa	
Set pressure range		5.1 to - 101.3kPa { 0.052 to - 1.033kgf/cm <sup>2</sup> , 0.051 to - 1.013bar } { 0.74 to - 14.70psi, 38 to - 760mmHg } 1.5 to - 29.9inHg		- 0.050 to 1.050MPa { - 0.51 to 10.71kgf/cm <sup>2</sup> } { - 0.50 to 10.50bar } { - 7.2 to 152.2psi }		- 101.3 to 105.0kPa { - 1.033 to 1.071kgf/cm <sup>2</sup> } { - 1.013 to 1.050bar } { - 14.68 to 15.22psi }	
Pressure withstandability		490kPa		1.470MPa		490kPa	
Applicable fluid		Non-corrosive gas					
Hysteresis		1 digit (however, variable in hysteresis mode)					
Repeatability		Within ± 0.2% F.S. ± 1 digit (within ± 3 digits)				Within ± 0.2% F.S. ± 2 digits (within ± 6 digits)	
Supply voltage		12 to 24V DC $\pm 10\%$ $\pm 15\%$ Ripple P-P 10% or less					
Current consumption		40mA or less					
Output		<NPN output type> NPN open-collector transistor • Maximum sink current: 100mA • Applied voltage: 30V DC or less (between output and 0V) • Residual voltage: 1V or less (at 100mA sink current) 0.4V or less (at 16mA sink current)			<PNP output type> PNP open-collector transistor • Maximum source current: 100mA • Applied voltage: Same as supply voltage (between output and +V) • Residual voltage: 2V or less (at 100mA source current)		
	Utilization category	DC-12 or DC-13					
	Output operation	NO/NC (selectable by key operation)					
	Output modes	Equipped with 4 types of modes: hysteresis mode, window comparator mode, automatic sensitivity setting mode, forced output mode (selectable by key operation)					
	Short-circuit protection	Incorporated					
Response time		2ms, 16ms, 128ms, 512ms or less (selectable by key operation)					
Display		3 1/2 digit LCD display (with red and green backlight) (Sampling rate: 256ms, 512ms, 1,024ms selectable by key operation)					
	Displayable pressure range	5.1 to - 101.3kPa { 0.052 to - 1.033kgf/cm <sup>2</sup> , 0.051 to - 1.013bar } { 0.74 to - 14.70psi, 38 to - 760mmHg } 1.5 to - 29.9inHg		- 0.050 to 1.050MPa { - 0.51 to 10.71kgf/cm <sup>2</sup> } { - 0.50 to 10.50bar } { - 7.2 to 152.2psi }		- 101.3 to 105.0kPa { - 1.033 to 1.071kgf/cm <sup>2</sup> } { - 1.013 to 1.050bar } { - 14.68 to 15.22psi }	
Analog bar display		Bar display in steps of 14% F.S. approx.					
Operation display		LCD segment is red when output is ON, and green when output is OFF					
Environmental resistance	Pollution degree	3 (Industrial environment)					
	Protection	IP40 (IEC)					
	Ambient temperature	0 to + 50°C (No dew condensation), Storage: - 10 to + 60°C					
	Ambient humidity	35 to 85% RH, Storage: 35 to 85% RH					
	EMC	Emission: EN50081-2, Immunity: EN50082-2					
	Voltage withstandability	1,000V AC for one min. between all supply terminals connected together and enclosure					
	Insulation resistance	50MΩ, or more, with 500V DC megger between all supply terminals connected together and enclosure					
	Vibration resistance	10 to 150Hz frequency, 0.75mm amplitude, or 5G in X, Y and Z directions for two hours each					
Shock resistance	100m/s <sup>2</sup> acceleration (10G approx.) in X, Y and Z directions for three times each						
Temperature characteristics		Over ambient temperature range + 10 to + 40°C: within ± 2% F.S. of detected pressure at + 25°C Over ambient temperature range 0 to + 50°C: within ± 5% F.S. of detected pressure at + 25°C					
Pressure port		M5 female thread					
Material		Front case: ABS, LCD display: PET, Rear case: PBT [M5 threaded part: Brass (nickel plated)]					
Connecting method		Connector connection					
Suitable cable	Conductor cross-section area (Note)	0.16 to 0.32mm <sup>2</sup> (AWG#25 to 22)					
	Lead wire diameter	φ 1.2 to φ 1.8mm					
	Cable length	2m					
	Wire material	Tin plated, soft, twisted copper wire					
Cable extension		Extension up to total 100m is possible with 0.3mm <sup>2</sup> , or more, cable.					
Weight		30g approx.					
Accessories		Panel mounting bracket ( <b>MS-DP-1</b> ): 1 set, Pressure unit label: 1 No. Connector: 1 set (Housing: 1 No., Connector pin: 3 Nos.)					

Note: If the wiring is longer than 2m, use a cable with a diameter of 0.3mm<sup>2</sup> or more.

## I/O CIRCUIT AND WIRING DIAGRAMS

### NPN output type

#### I/O circuit diagram

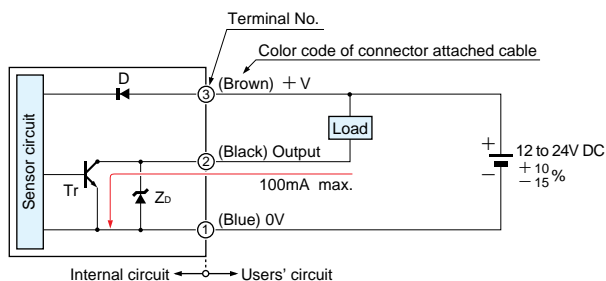

#### Pin position

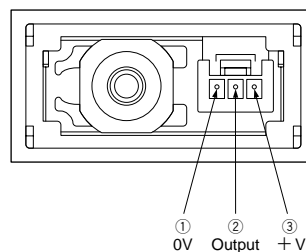

Symbols ... D : Reverse supply polarity protection diode  
 Zd: Surge absorption zener diode  
 Tr: NPN output transistor

### PNP output type

#### I/O circuit diagram

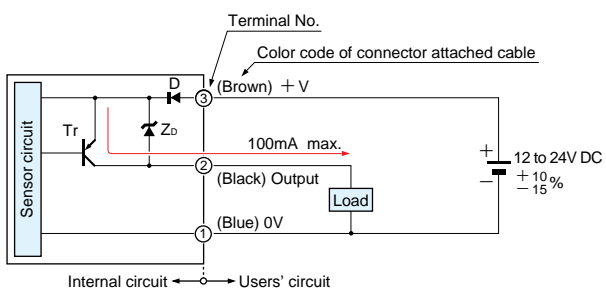

#### Pin position

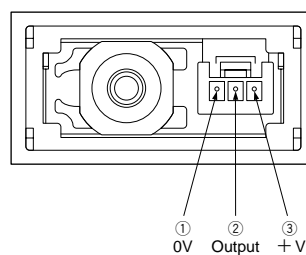

Symbols ... D : Reverse supply polarity protection diode  
 Zd: Surge absorption zener diode  
 Tr: PNP output transistor

## PRECAUTIONS FOR PROPER USE



- This product is not a safety sensor. Its use is not intended or designed to protect life and prevent body injury or property damage from dangerous parts of machinery. It is a normal pressure detection sensor.
- The DP4 series is designed for use with non-corrosive gas. It cannot be used with liquid or corrosive gas.

### Functional description

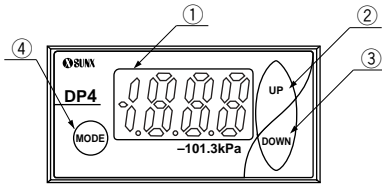

	Description	Function
①	3 1/2 digit LCD display (with red and green backlight)	<ul style="list-style-type: none"> <li>• Displays measured pressure, settings, error messages and key-protect status.</li> <li>• Red display when output is ON.</li> <li>• Green display when output is OFF.</li> </ul>
②	Increment key (UP)	<ul style="list-style-type: none"> <li>• In the initial setting mode and supplementary setting mode, pressing the key changes the setting item.</li> <li>• In the pressure value setting mode, pressing the key changes the set value.</li> <li>• In the sensing mode, pressing the key continuously for 4 sec., or more, displays the peak hold value.</li> </ul>
③	Decrement key (DOWN)	<ul style="list-style-type: none"> <li>• In the initial setting mode and supplementary setting mode, pressing the key changes the set conditions.</li> <li>• In the pressure value setting mode, pressing the key changes the set value.</li> <li>• In the sensing mode, pressing the key continuously for 4 sec., or more, displays the bottom hold value.</li> </ul>
④	Mode selection key (MODE)	<ul style="list-style-type: none"> <li>• In the pressure setting mode, pressing the key changes the setting item. In addition, if pressed for 4 sec., or more, in Set Value 1 (P-1) or Set Value 4 (P-4) setting mode, the setting mode will change to either Set Value 4 (P-4) or Set Value 1 (P-1) setting mode.</li> <li>• In the sensing mode, pressing the key continuously for 4 sec., or more, can set/cancel the key-protect.</li> <li>• In the sensing mode, pressing both Increment key and Mode selection key simultaneously changes the mode to the initial setting mode. Whereas, pressing both Decrement key and Mode selection key simultaneously changes the mode to the supplementary setting mode.</li> </ul>

In the sensing mode, if both keys are simultaneously pressed continuously, zero-point adjustment is done.

### Error messages

- When an error occurs, take the following corrective action.

Error message	Cause	Corrective action
	Overcurrent due to short-circuit.	Switch off the power supply and check the load.
	Pressure is being applied during zero-point adjustment.	Applied pressure at the pressure port should be brought to atmospheric pressure and zero-point adjustment should be done again.
	Positive pressure and compound pressure types	Applied pressure exceeds the upper limit of displayable pressure range.
	Vacuum pressure type	Applied pressure exceeds the lower limit (reverse pressure) of displayable pressure range.
	Positive pressure and compound pressure types	Applied pressure exceeds the lower limit (reverse pressure) of displayable pressure range.
	Vacuum pressure type	Applied pressure exceeds the upper limit of displayable pressure range.

Applied pressure should be brought within the rated pressure range.

### Wiring

- Make sure to carry out the wiring in the power supply off condition.
- Verify that the supply voltage variation is within the rating.
- If power is supplied from a commercial switching regulator, ensure that the frame ground (F.G.) terminal of the power supply is connected to an actual ground.
- In case noise generating equipment (switching regulator, inverter motor, etc.) is used in the vicinity of this sensor, connect the frame ground (F.G.) terminal of the equipment to an actual ground.
- If the used power supply generates a surge, connect a surge absorber to the power supply to absorb the surge.
- Do not run the wires together with high-voltage lines or power lines or put them in the same raceway. This can cause malfunction due to induction.
- In order to reduce noise, make the wiring as short as possible.

### Others

- Use within the rated pressure range.
- Do not apply pressure exceeding the pressure withstandability value. The diaphragm will get damaged and correct operation shall not be maintained.
- Do not use during the initial transient time (3 sec. approx.) after the power supply is switched on.
- Avoid dust, dirt, and steam.
- Take care that the sensor does not come in direct contact with water, oil, grease, or organic solvents, such as, thinner, etc.
- Do not insert wires, etc., into the pressure port. The diaphragm will get damaged and correct operation shall not be maintained.
- Do not operate the keys with pointed or sharp objects.



## PRECAUTIONS FOR PROPER USE

### Setting

- If key-protect has been set, make sure to release key-protect before operating the keys. (Please refer to 'Key-protect function' for the procedure.)
- Set Value 1 (P-1) and Set Value 2 (P-2) can be made common for all the output modes.
- The setting of Set Value 2 (P-2) with respect to Set Value 1 (P-1) can only be towards the high pressure side in case of the positive pressure type sensor and only towards the high vacuum side in case of the vacuum pressure type sensor.
- The conditions which are set are stored in an EEPROM. Kindly note that the EEPROM has a life span and its guaranteed life is 100,000 write operation cycles.

### Setting procedure

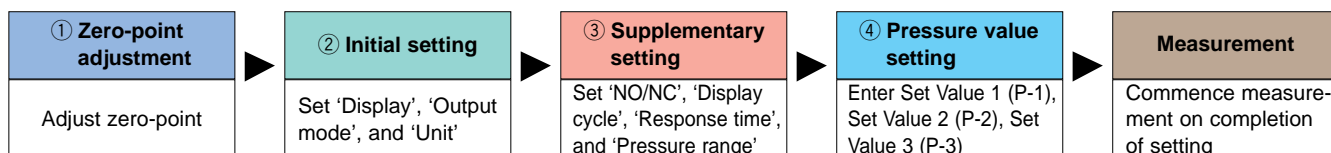

#### ① Zero-point adjustment

- The displayed pressure when the pressure port is left open is adjusted to zero.

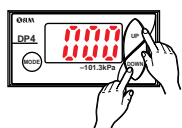

- The sensor will automatically enter the sensing mode when power is supplied.
- Let the pressure port be at atmospheric pressure (i.e., no applied pressure condition), and press, simultaneously, the UP and DOWN keys continuously.
- **0000** is displayed and, when the fingers are released, zero-point adjustment is completed and the sensor returns to the sensing mode.

#### ② Initial setting

- Pressure 'Unit', 'Display', and 'Output mode' of the outputs are set.

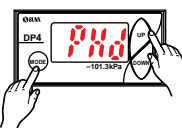

- In the sensing mode, press **↵** key while pressing UP key.
- Initial setting is displayed.
- If sensor is being used for the first time, **PHd** is displayed.
- The settable digit blinks.
- The settable digit changes when UP key is pressed and the setting is changed when DOWN key is pressed.

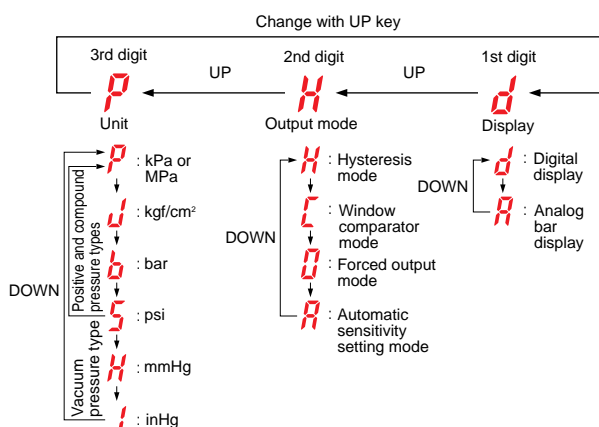

#### ③ Supplementary setting

- 'NO/NC', 'Display cycle', 'Response time' and 'Pressure range' are set.

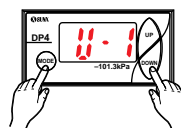

- In the sensing mode, press both DOWN key and **↵** key simultaneously.
- The setting item and the setting condition are displayed alternately.
- The setting item changes when UP key is pressed.
- The set condition of each item changes when DOWN key is pressed.

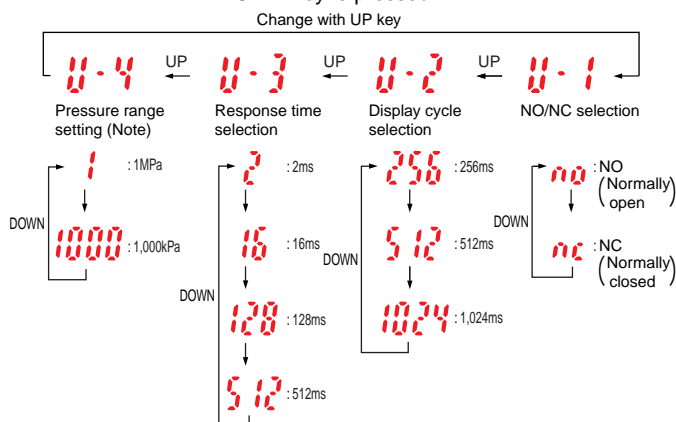

Note: Displayable only for positive pressure type DP4-52 (P).

#### ④ Pressure value setting

- Sets output to Set Value 1 to 3 (P-1 to P-3).
- Press the **↵** key in sensing mode.
- The mode changes in the order Set Value 1 (P-1) setting mode, Set Value 2 (P-2) setting mode and Set Value 3 (P-3) setting mode each time the **↵** key is pressed.

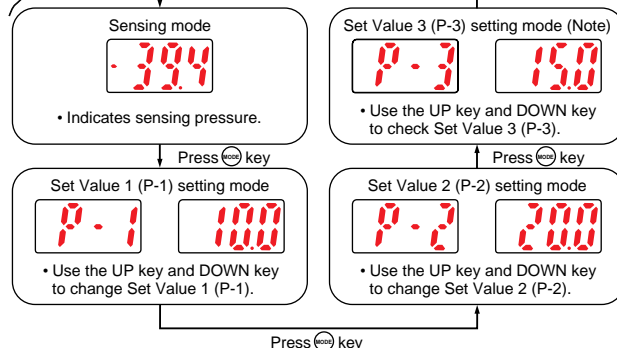
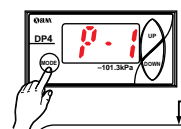

Note: Set Value 3 is only displayed when automatic sensitivity setting mode has been set. Furthermore, if Set Value 3 is between Set Value 1 and Set Value 2, the UP key and DOWN key can be used to correct it.

## PRECAUTIONS FOR PROPER USE

### Forced output mode

- In the initial setting mode, if the output mode is set to the forced output mode (0), the output is forcibly maintained at OFF level in the sensing mode, irrespective of Set Value 1 to 3.

Further, if the keys are operated as per the procedure given below, the output can be forcibly switched either ON or OFF without applying pressure at the pressure port. This is convenient for an operation check of the comparative output or for an inspection before commencing work.

{ The diagram below appears when the DP4-50 (P) has been used to set the display to 'Digital display' (d). }

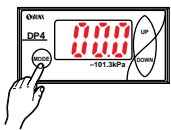

- In the sensing mode, press MODE key to change to the forced output mode.
- Whenever UP key is pressed, the output state switches to either ON and OFF alternately.
- Press MODE key to return to the sensing mode.

- Output is kept off at the point where the mode is changed from another output mode to forced output control mode (0).
- Even if output has been set to stay on during forced output control mode, it will be forcibly changed to off at the point where the mode changes back to sensing mode.

### Memory bank function

- The memory bank function is a function which allows two types of output to be stored: Set Values 1 to 3 (P-1 to P-3) and Set Values 4 to 6 (P-4 to P-6).

This make it possible to change set values quickly.

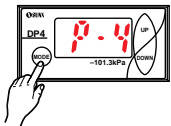

- If the MODE key is pressed in a sensing mode other than forced output mode, the mode will change to pressure value setting mode.
- After releasing the mode select key, press the MODE key again continuously until P-4 is displayed (4 sec. or more).
- Make the setting for Set Values 4 to 6 (P-4 to P-6). Set Values 4 to 6 (P-4 to P-6) correspond to Set Values 1 to 3 (P-1 to P-3) respectively. Refer to **④ Pressure value setting** (P.8) for details on making each setting.

### Peak hold & bottom hold functions

- Peak hold and bottom hold functions enable the display of the peak value (maximum pressure value) and the bottom value (minimum pressure value) of the varying measured pressure.

These functions are convenient for finding the pressure variation range or for determining the reference for pressure settings.

- Please note that the peak value and the bottom value data is erased when it is no longer displayed.

#### Peak hold display

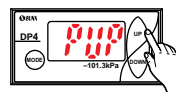

↑  
↓  
Displayed alternately

- In the sensing mode, keep UP key pressed until P00 is displayed. (4 sec. or more)
- When the finger is released after P00 is displayed, the peak value and P00 are displayed alternately.
- Press UP key.



#### Bottom hold display

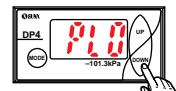

↑  
↓  
Displayed alternately

- In the sensing mode, keep DOWN key pressed until P10 is displayed. (4 sec. or more)
- When the finger is released after P10 is displayed, the bottom value and P10 are displayed alternately.
- Press DOWN key.

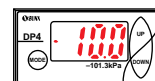

### Key-protect function

- Key-protect is a function which prevents any unintentional change in the conditions which have been entered in each setting mode by making the sensor not to respond to the key operations.

#### Setting of key-protect

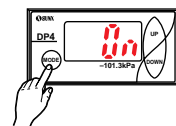

- In the sensing mode, press MODE key continuously for 4 sec, or more, and release it immediately when 00 is displayed.
- Key-protect is set and the sensor returns to the sensing mode.

- Since the key-protect information is stored in an EEPROM, it is not erased even if the power supply is switched off.
- Please take care to remember if the key-protect function has been set.

#### Release of key-protect

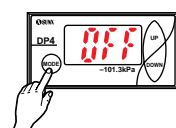

- In the sensing mode, press MODE key continuously for 4 sec, or more, and release it immediately when OFF is displayed.
- Key-protect is released and the sensor returns to the sensing mode.

- When the keys are to be operated, make sure that key-protect is released.

## PRECAUTIONS FOR PROPER USE

### Piping

- When connecting a commercial M5 coupling to the pressure port, hold the flat sides of the pressure port with a 13mm spanner and make sure that the tightening torque is 1N·m or less. If excessive tightening torque is applied, the commercial fitting may break.

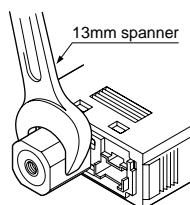

### Mounting

- Install the enclosed panel mounting bracket (**MS-DP-1**) as shown in the figure below. The tightening torque should be 0.15N·m or less. Further, tighten both the right and the left screw gradually and equally, so that the panel mounting bracket does not tilt.

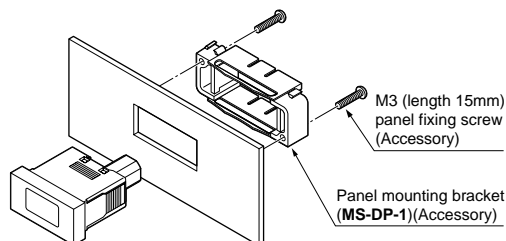

## DIMENSIONS (Unit: mm)

### DP4-5□ Sensor

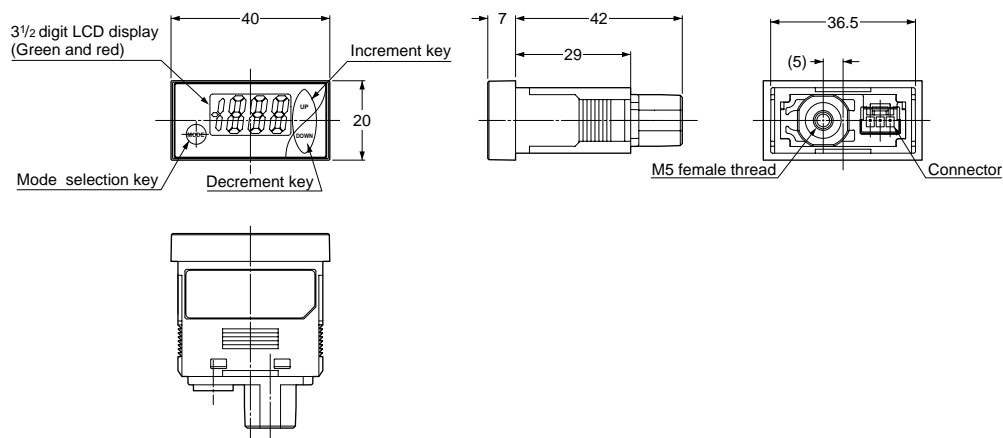

### MS-DP-2 DIN rail mounting bracket (Optional)

#### Assembly dimensions

##### <Horizontal mounting>

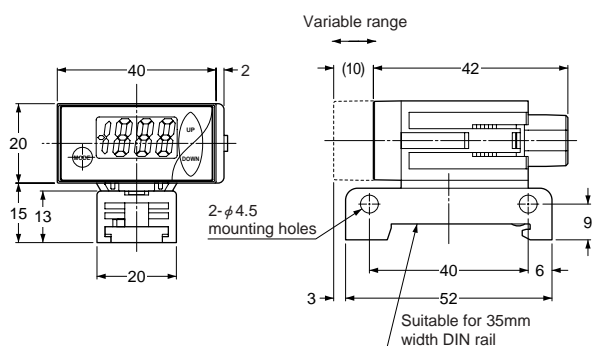

##### <Vertical mounting>

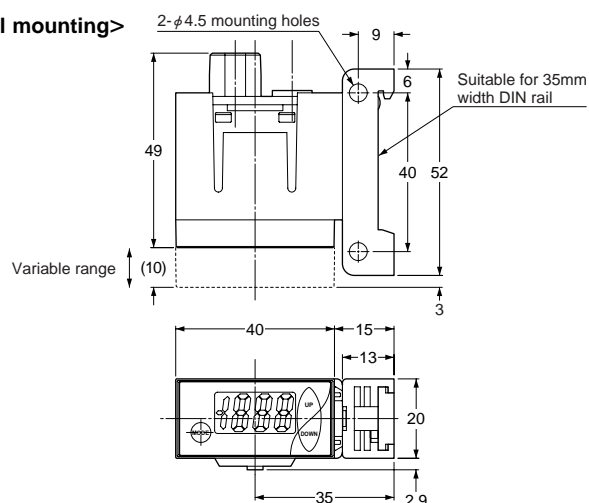

# DP4 SERIES COMPACT SIZE · DIGITAL PRESSURE SENSOR

## DIMENSIONS (Unit: mm)

### MS-DP-1 Panel mounting bracket (Accessory)

#### Assembly dimensions

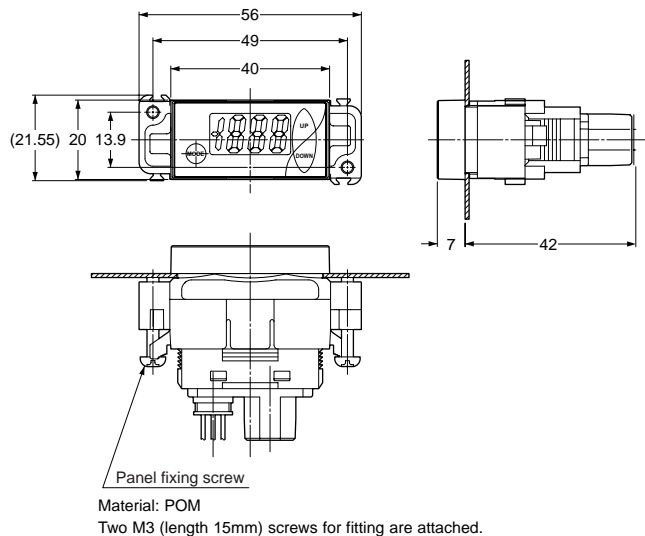

#### Panel cut-out dimensions

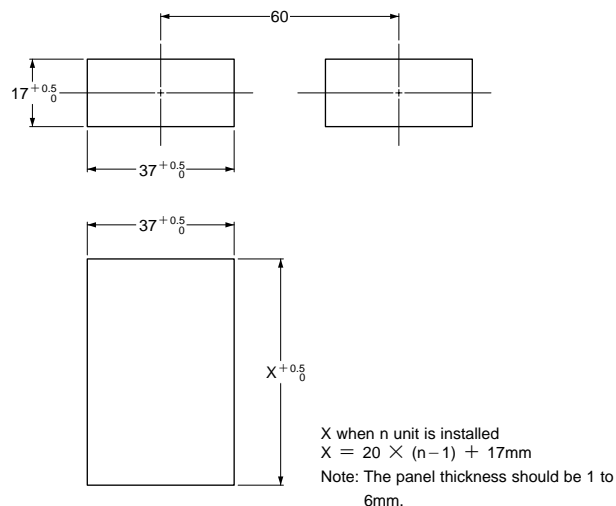

### CN-63 Connector (Optional)

#### <Housing>

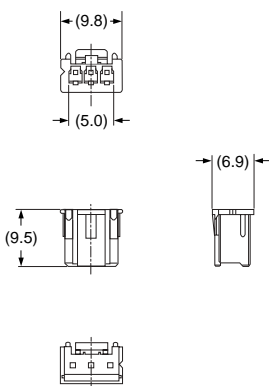

#### <Connector bracket>

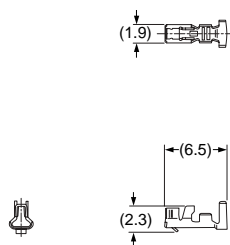

Connector  
Connector pin: BXA-001T-P0.6 manufactured by J. S. T. MFG CO., LTD.  
Housing: XAP-03V-1 manufactured by J. S. T. MFG CO., LTD.

### CN-63-C2 Connector attached cable (Optional)

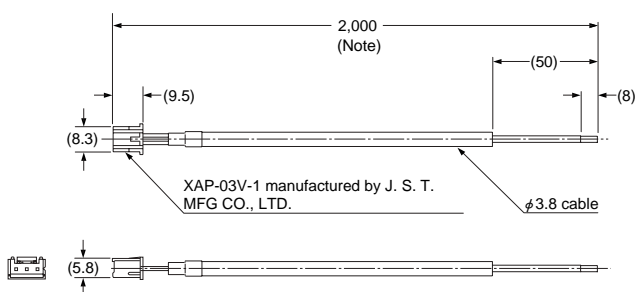

Note: 5m cable length type (CN-63-C5) is 5,000mm



All information is subject to change without prior notice.

#### SUNX Limited

2431-1 Ushiyama-cho, Kasugai-shi,  
Aichi, 486-0901, Japan  
Phone: +81-(0)568-33-7211  
FAX: +81-(0)568-33-2631

#### Overseas Sales Dept.

Phone: +81-(0)568-33-7861  
FAX: +81-(0)568-33-8591

Printed on 100% recycled paper

PRINTED IN JAPAN

Internet home page  
<http://www.sunx.co.jp/>

Welcome to SUNX



No. CE-DP4-C-5 July, 2002