

7/8" (22.2 mm) Single Turn Conductive Plastic Precision Potentiometer

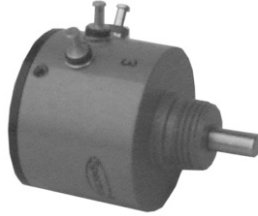

FEATURES

- Virtually infinite resolution
- Bushing mount and servo mount types available
- Rotational life exceeds 20 million shaft revolutions
- Co-molded track and multi-finger wiper provide low noise signal
- Ohmic value range: 500 Ω to 50 kΩ
- Compliant to RoHS directive 2002/95/EC



ELECTRICAL SPECIFICATIONS		
PARAMETER		
Total Resistance Standard Range	500 Ω to 50 kΩ	
Tolerance:	STANDARD ± 10 %	SPECIAL ± 5 %
Linearity (Independent)	STANDARD ± 0.5 %	SPECIAL ± 0.2 %
Electrical Angle	340° ± 5°	
Power Rating Section 1: Additional Sections:	1.0 W at 70° ambient derated to zero at 125 °C 75 % of the rating of section 1	
Output Smoothness	0.1 % maximum	
Insulation Resistance	1000 MΩ minimum, 500 V _{DC}	
Dielectric Strength	1000 V _{RMS} , 60 Hz from Terminals to shaft	
Taps (Extra)	Extra taps available as special	
Phasing	Points at which output is 0.5 aligned ± 1° (ref. to section 1)	
Temperature Coefficient of Resistance	± 600 ppm/°C maximum	

ORDERING INFORMATION/DESCRIPTION				
The Model 708 can be ordered from this data sheet with a variety of alternate characteristics, as shown. For most rapid service on your order, please state:				
708	B	1	10K	B01
MODEL	MOUNTING	NUMBER OF SECTIONS	TOTAL RESISTANCE OF EACH SECTION	PACKAGING
	B: Bushing S: Servo	Up to 6	Beginning with the section nearest the mounting end	Box of 1 piece
Other characteristics will be standard as described on this data sheet. If special characteristics are required, such as: special linearity tolerance, special resistance tolerance, extra taps, non-linear functions, etc., please state these on your order and allow additional lead time for delivery.				

SAP PART NUMBERING GUIDELINES					
708	S	2	102	103	B01
MODEL	STYLE	GANGS	OHMIC VALUE GANG Nº 1	OHMIC VALUE GANG Nº 2	PACKAGING
	B: Bushing S: Servo	From 1 up to 6	1K	10K	

Model 708



Vishay Spectrol

7/8" (22.2 mm) Single Turn Conductive Plastic Precision Potentiometer

DIMENSIONS in inches (millimeters)

BUSHING MOUNT: 708 B

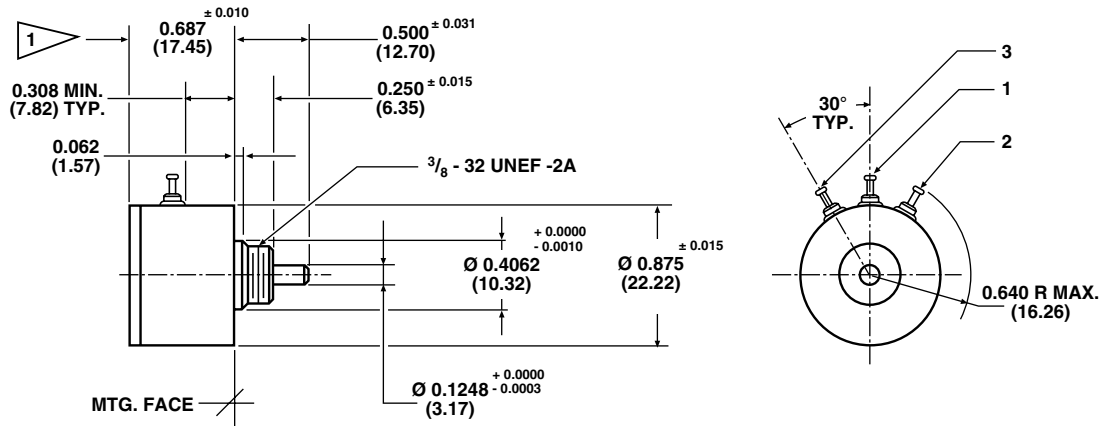

SERVO MOUNT: 708 S

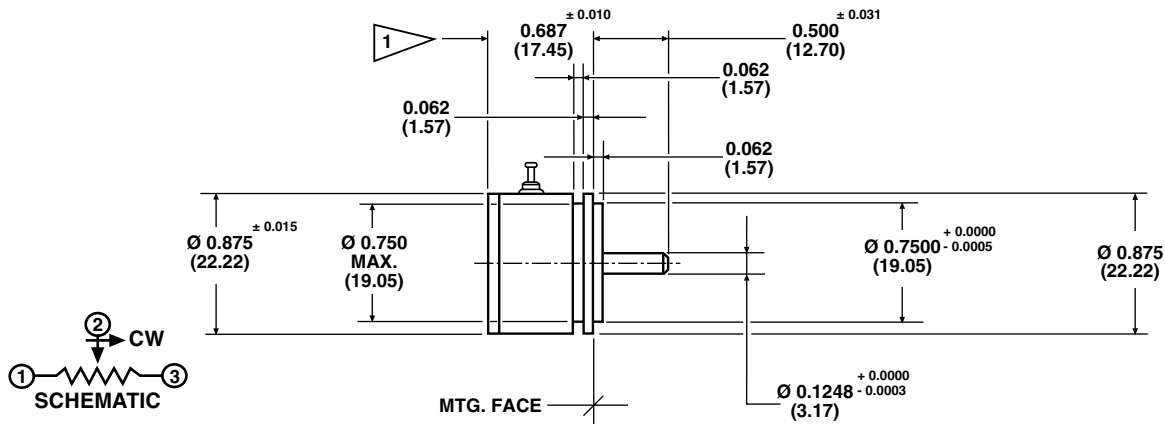

TOLERANCES: UNLESS OTHERWISE NOTED.
DECIMALS ± 0.005 ANGLES ± 2°

1 ADD 0.500 ± 0.002 (12.70) FOR EACH ADDITIONAL SECTION

MECHANICAL SPECIFICATIONS		
PARAMETER		
Rotation	360° continuous	
Bearing Type Servo Mount: Bushing Mount:	Ball bearing Sleeve bearing	
Torque (Maximum) Servo, 1 Section Bushing, 1 Section Each Additional Section	STARTING 0.10 oz. - in (7.20 g - cm) 0.25 oz. - in (18.00 g - cm) 0.10 oz. - in (7.20 g - cm)	RUNNING 0.085 oz. - in (6.12 g - cm) 0.20 oz. - in (14.40 g - cm) 0.075 oz. - in (5.40 g - cm)
Runouts (Maximum) Shaft Runout (TIR/in) Pilot Dia. Runout (TIR) Lateral Runout (TIR) Shaft End Play Shaft Radial Play	SERVO 0.002" (0.05 cm) 0.002" (0.05 cm) 0.002" (0.05 cm) 0.005" (0.13 cm) 0.002" (0.05 cm)	BUSHING 0.002" (0.05 cm) 0.002" (0.05 cm) 0.005" (0.13 cm) 0.005" (0.13 cm) 0.004" (0.10 cm)
Weight (Maximum) Single Section: Each Additional Section:	0.6 oz. (17.0 g) 0.2 oz. (5.67 g)	
Ganging	6 sections max, terminal alignment, added sections within ± 10° of section 1 terminals	
Moment of Inertia	0.12 g - cm ² per section maximum	



**7/8" (22.2 mm) Single Turn Conductive Plastic
Precision Potentiometer**

Vishay Spectrol

MATERIAL SPECIFICATIONS	
Housing and Lids	Aluminum, anodized
Shaft	Stainless steel, non-magnetic non-passivated
Terminals	Brass plated for solderability
Bushing Mount Hardware Lockwasher Internal tooth: Panel Nut:	Steel, nickel plated Brass, nickel plated

ENVIRONMENTAL SPECIFICATIONS	
Vibration	15 g thru 2000 Hz
Shock	50 g
Salt Spray	96 h
Rotational Life	Servo: 20 million shaft revolutions Bushing: 5 million shaft revolutions
Load Life	900 h
Temperature Range	- 55 °C to + 125 °C

MARKING	
Unit Identification	Units shall be marked with Spectrol name, model no, and data code, and on each section, resistance, resistance tolerance, linearity and terminal identification

POWER RATING CHART

(Ratings for cup No. 1.
Additional cups 75 % of values shown)

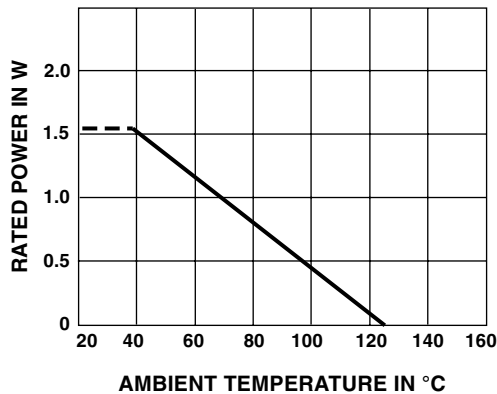

RESISTANCE ELEMENT DATA	
RESISTANCE VALUES (Ω)	MAXIMUM VOLTAGE APPLICABLE (V)
500	22
1K	32
2K	45
5K	71
10K	100
20K	141
50K	224



Disclaimer

ALL PRODUCT, PRODUCT SPECIFICATIONS AND DATA ARE SUBJECT TO CHANGE WITHOUT NOTICE TO IMPROVE RELIABILITY, FUNCTION OR DESIGN OR OTHERWISE.

Vishay Intertechnology, Inc., its affiliates, agents, and employees, and all persons acting on its or their behalf (collectively, "Vishay"), disclaim any and all liability for any errors, inaccuracies or incompleteness contained in any datasheet or in any other disclosure relating to any product.

Vishay makes no warranty, representation or guarantee regarding the suitability of the products for any particular purpose or the continuing production of any product. To the maximum extent permitted by applicable law, Vishay disclaims (i) any and all liability arising out of the application or use of any product, (ii) any and all liability, including without limitation special, consequential or incidental damages, and (iii) any and all implied warranties, including warranties of fitness for particular purpose, non-infringement and merchantability.

Statements regarding the suitability of products for certain types of applications are based on Vishay's knowledge of typical requirements that are often placed on Vishay products in generic applications. Such statements are not binding statements about the suitability of products for a particular application. It is the customer's responsibility to validate that a particular product with the properties described in the product specification is suitable for use in a particular application. Parameters provided in datasheets and/or specifications may vary in different applications and performance may vary over time. All operating parameters, including typical parameters, must be validated for each customer application by the customer's technical experts. Product specifications do not expand or otherwise modify Vishay's terms and conditions of purchase, including but not limited to the warranty expressed therein.

Except as expressly indicated in writing, Vishay products are not designed for use in medical, life-saving, or life-sustaining applications or for any other application in which the failure of the Vishay product could result in personal injury or death. Customers using or selling Vishay products not expressly indicated for use in such applications do so at their own risk and agree to fully indemnify and hold Vishay and its distributors harmless from and against any and all claims, liabilities, expenses and damages arising or resulting in connection with such use or sale, including attorneys fees, even if such claim alleges that Vishay or its distributor was negligent regarding the design or manufacture of the part. Please contact authorized Vishay personnel to obtain written terms and conditions regarding products designed for such applications.

No license, express or implied, by estoppel or otherwise, to any intellectual property rights is granted by this document or by any conduct of Vishay. Product names and markings noted herein may be trademarks of their respective owners.