

金属遊星ギヤ採用、ギヤ強度従来比 1.5 ~ 2.5 倍

DC ギヤードモータ
DC GEARED MOTORS

MG16B

DCギヤードモータ

RoHS 指令対応 RoHS compliant



型式表示 PART NUMBER DESIGNATION

MG16B - 060 - A B - 00

シリーズ名 Series name

定格電圧 Rated voltage

A : DC6 V B : DC12 V

ギヤ比 Gear ratio

030 : 1/30 60 : 1/60 120 : 1/120
240 : 1/240 300 : 1/300

型式 / 仕様一覧表 LIST OF PART NUMBER & SPECIFICATIONS

減速比 Gear Ratio	定格電圧 Rated Voltage	型式 Part Number	トルク Torque (mNm)			回転数 Speed (nin ¹) (Reference)		電流 Current (mA)			全長 Length (mm)		質量 Weight (g) (Reference)
			定格 Rated	許容最大値 Max.	起動 Starting	無負荷 No-Load	定格 Rated	無負荷 No-Load	定格 Rated	起動 Starting	本体 Motor	ギヤ部 Gear	
1/30	DC6 V	MG16B-030-AA-00	20	30	> 50	477	380	< 160	< 400	< 1600	35	14 〔遊星ギヤ 2段〕	25
	DC12 V	MG16B-030-AB-00						< 80	< 250	< 800			
1/60	DC6 V	MG16B-060-AA-00	40	60	> 100	213	160	< 160	< 400	< 1600	38	17 〔遊星ギヤ 2段〕	30
	DC12 V	MG16B-060-AB-00						< 80	< 250	< 800			
1/120	DC6 V	MG16B-120-AA-00	60	90	> 170	127	100	< 160	< 400	< 1600	41	20 〔遊星ギヤ 4段〕	35
	DC12 V	MG16B-120-AB-00						< 80	< 250	< 800			
1/240	DC6 V	MG16B-240-AA-00	120	180	> 350	53	40	< 160	< 400	< 1600	41	20 〔遊星ギヤ 4段〕	35
	DC12 V	MG16B-240-AB-00						< 80	< 250	< 800			
1/300	DC6 V	MG16B-300-AA-00	160	240	> 400	45	34	< 160	< 400	< 1600	41	20 〔遊星ギヤ 4段〕	35
	DC12 V	MG16B-300-AB-00						< 80	< 250	< 800			

※ 定格 24V、ギヤ比 1/15、1/500、1/650 も対応検討可能です。

Can also correspond to review for the rated voltage 24V, the gear ratios 1/15, 1/500, and 1/650.

MG16B

DC GEARED MOTORS

DCギヤードモータ

■特性図 PERFORMANCE CURVES (数値は定格運転条件での代表値です。) (Figures in the table are typical values under rated operating condition.)

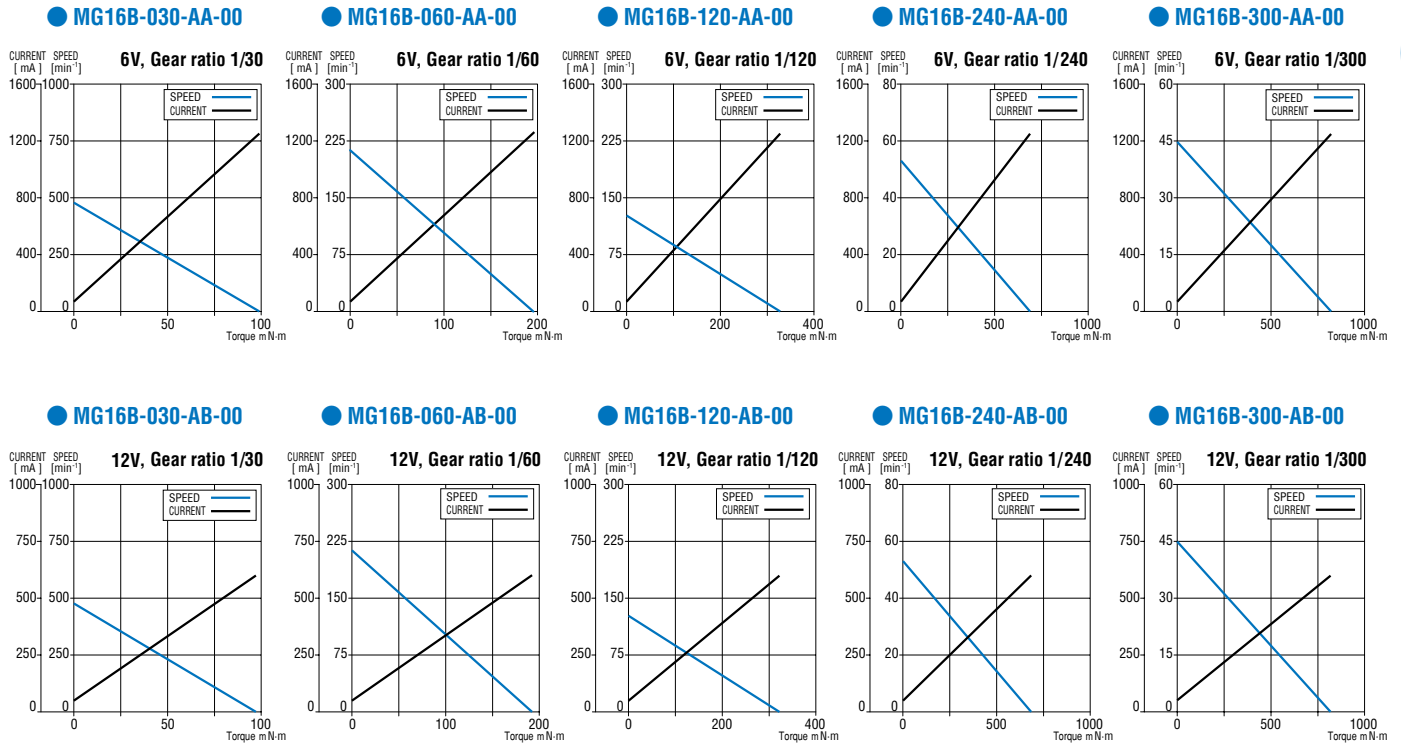

■外形寸法図 OUTLINE DIMENSIONS

(Unit: mm)

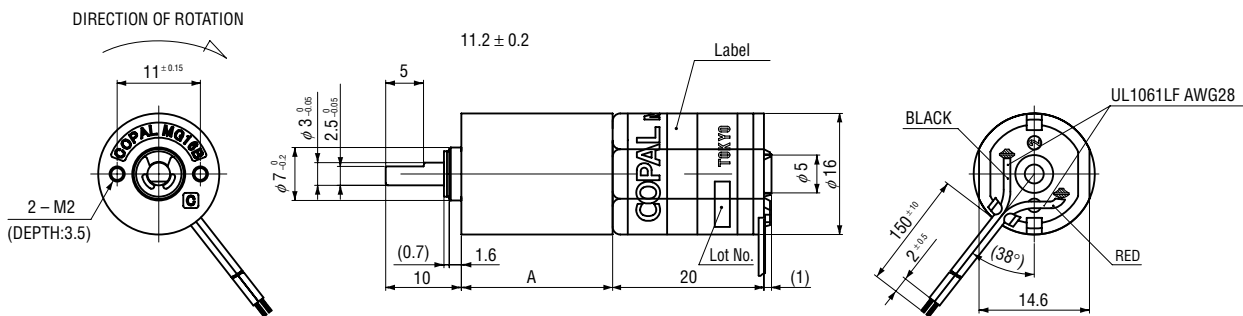

符号記号 Mark A

Gear ratio	1/30	1/60	1/120	1/240	1/300
A	14	17	20		