

Quad Monolithic SPST CMOS Analog Switches

Features

- $\pm 15\text{-V}$ Analog Input Range
- Low On-Resistance: $60\ \Omega$
- Fast Switching: $130\ \text{ns}$
- Low Power Dissipation: $30\ \text{nW}$
- CMOS Logic Compatible

Benefits

- Full Rail-to-Rail Analog Signal Range
- Low Signal Error
- Wide Dynamic Range
- Single or Dual Supply Capability
- Static Protected Logic Inputs
- Space Savings (TSSOP)

Applications

- Portable and Battery Powered Instrumentation
- Communication Systems
- Computer Peripherals
- High-Speed Multiplexing

Description

The DG308A and DG309 are quad single-pole single-throw analog switches designed for high speed switching applications in communications, instrumentation, and process control. This series is well suited for applications requiring a low on-resistance over the entire analog range.

Featuring low on-resistance ($60\ \Omega$) and fast switching ($130\ \text{ns}$), the DG308A is supplied in the "normally open" configuration while DG309 is supplied "normally closed."

Input thresholds are high voltage CMOS compatible.

Designed with the Siliconix PLUS-40 CMOS process to combine low power dissipation with a high breakdown voltage rating of $44\ \text{V}$, each switch conducts equally well in both directions when on, and blocks up to the supply voltage when off. An epitaxial layer prevents latch up.

The DG308B/309B upgrades are recommended for new designs.

Functional Block Diagram and Pin Configuration

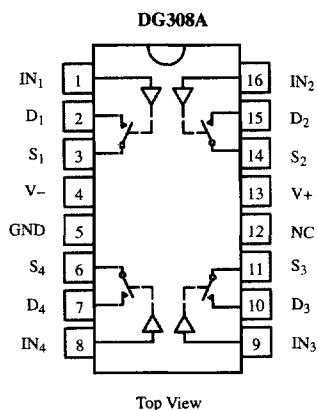

Four SPST Switches per Package

Truth Table

Logic	DG308A	DG309
0	OFF	ON
1	ON	OFF

Logic "0" $\leq 3.5\ \text{V}$
Logic "1" $\geq 11\ \text{V}$

Updates to this data sheet may be obtained via facsimile by calling Siliconix FaxBack, 1-408-970-5600. Please request FaxBack document #70046.

Ordering Information

Temp Range	Package	Part Number
0 to 70°C	16-Pin Plastic DIP	DG308ACJ
		DG309CJ
-40 to 85°C	16-Pin Narrow SOIC	DG308ADY
		DG309DY
	16-Pin TSSOP	DG308ADQ
		DG309DQ
-55 to 125°C	16-Pin CerDIP	DG308AAK/883
		DG309AK/883

Absolute Maximum Ratings

Voltages Referenced to V-

V+ 44 V
 GND 25 V
 Digital Inputs^a, V_S, V_D (V-) -2 V to (V+) +2V or
 20 mA, whichever occurs first

Current, Any Terminal Except S or D 30 mA
 Continuous Current, S or D 20 mA
 (Pulsed at 1 ms, 10% duty cycle max) 70 mA

Storage Temperature (AK Suffix) -65 to 150°C
 (CJ, DY, and DQ Suffix) .. -65 to 125°C

Power Dissipation^b

16-Pin Plastic DIP^c 470 mW
 16-Pin Narrow SOIC and TSSOP^e 600 mW
 16-Pin CerDip^d 900 mW

Notes:

- Signals on S_X, D_X, or I_{NX} exceeding V+ or V- will be clamped by internal diodes. Limit forward diode current to maximum current ratings.
- All leads welded or soldered to PC Board.
- Derate 12 mW/°C above 75°C
- Derate 6.5 mW/°C above 25°C
- Derate 7.6 mW/°C above 75°C

Schematic Diagram (Typical Channel)

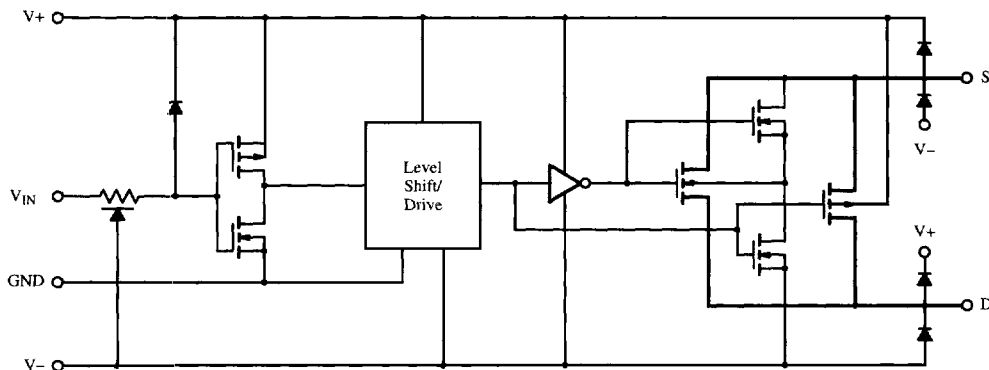

Figure 1.

4
Analog Switches

Specifications^a

Parameter	Symbol	Test Conditions Unless Otherwise Specified $V_+ = 15\text{ V}$, $V_- = -15\text{ V}$ $V_{IN} = 3.5\text{ V}$ or 11 V^f	Temp ^b	Typ ^c	A Suffix -55 to 125°C		C, D Suffix		Unit
					Min ^d	Max ^d	Min ^d	Max ^d	
Analog Switch									
Analog Signal Range ^e	V_{ANALOG}		Full		-15	15	-15	15	V
Drain-Source On-Resistance	$r_{DS(on)}$	$V_D = \pm 10\text{ V}$, $I_S = 1\text{ mA}$	Room Full	60		100 150		100 125	Ω
Source Off Leakage Current	$I_{S(off)}$	$V_S = \pm 14\text{ V}$, $V_D = \mp 14\text{ V}$	Room Full	± 0.1	-1 -100	1 100	-5 -100	5 100	nA
Drain Off Leakage Current	$I_{D(off)}$	$V_D = \pm 14\text{ V}$, $V_S = \mp 14\text{ V}$	Room Full	± 0.1	-1 -100	1 100	-5 -100	5 100	
Drain On Leakage Current	$I_{D(on)}$	$V_D = V_S = \pm 14\text{ V}$	Room Full	± 0.1	-1 -100	1 100	-5 -200	5 200	
Digital Control									
Input Current with Input Voltage High	I_{INH}	$V_{IN} = 15\text{ V}$	Full	0.001		1		1	μA
Input Current with Input Voltage Low	I_{INL}	$V_{IN} = 0\text{ V}$	Full	-0.001	-1		-1		
Input Capacitance	C_{IN}		Room	8					pF
Dynamic Characteristics									
Turn-On Time	t_{ON}	See Figure 2	Room	130		200		200	ns
Turn-Off Time	t_{OFF}		Room	90		150		150	
Charge Injection	Q	$C_L = 0.01\ \mu\text{F}$, $R_{gen} = 0\ \Omega$, $V_{gen} = 0\text{ V}$	Room	-10					pC
Source-Off Capacitance	$C_{S(off)}$	$f = 140\text{ kHz}$, V_S , $V_D = 0\text{ V}$	Room	11					pF
Drain-Off Capacitance	$C_{D(off)}$		Room	8					
Channel-On Capacitance	$C_{D(on)}$		Room	27					
Off-Isolation ^f	OIRR	$R_L = 75\ \Omega$, $V_S = 2\text{ V}_{p-p}$, $f = 500\text{ kHz}$	Room	78					dB
Power Supplies									
Positive Supply Current	I+	All Channels On or Off $V_{IN} = 0\text{ V}$ or 15 V	Room Full	0.001		10 100		10 100	μA
Negative Supply Current	I-		Room Full	-0.001	-10 -100		-100		

Notes:

- Refer to PROCESS OPTION FLOWCHART.
- Room = 25°C, Full = as determined by the operating temperature suffix.
- Typical values are for DESIGN AID ONLY, not guaranteed nor subject to production testing.
- The algebraic convention whereby the most negative value is a minimum and the most positive a maximum, is used in this data sheet.
- Guaranteed by design, not subject to production test.
- V_{IN} = input voltage to perform proper function.

Typical Characteristics

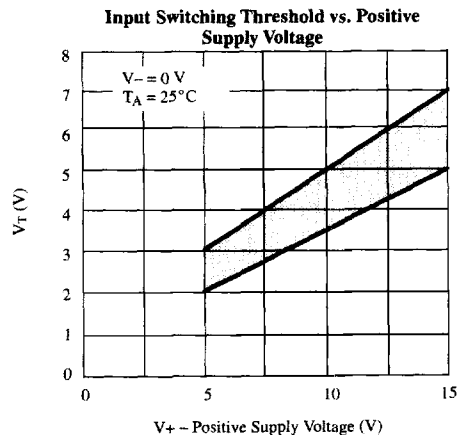
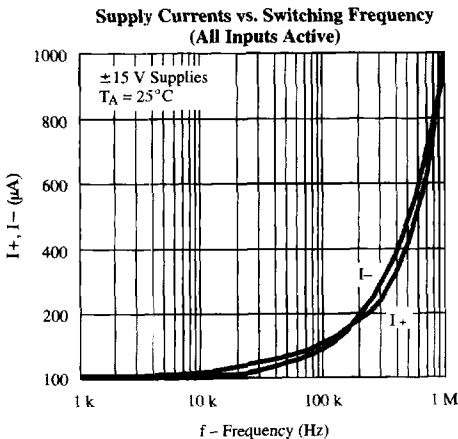
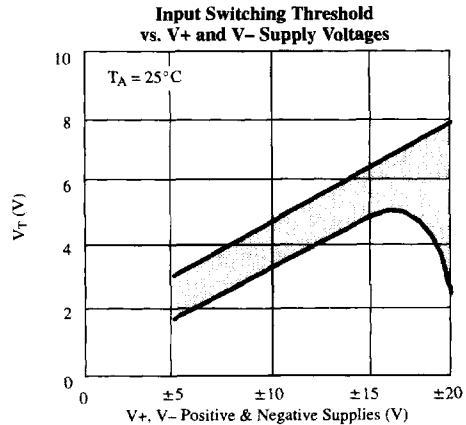
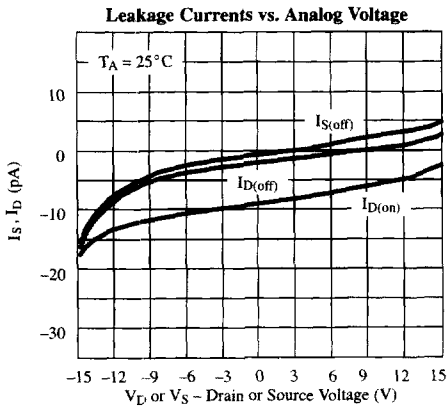
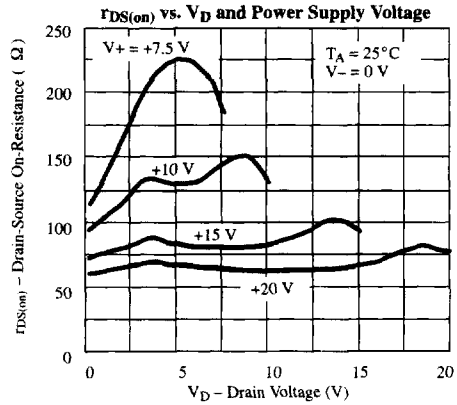
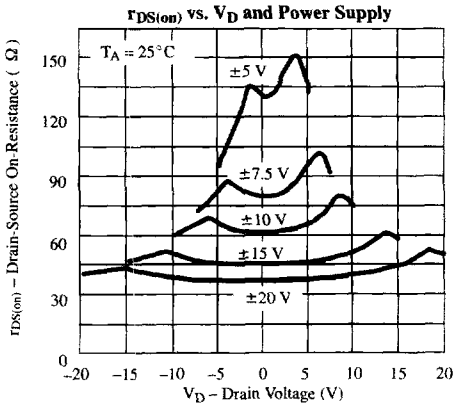

Analog Switches

Test Circuits

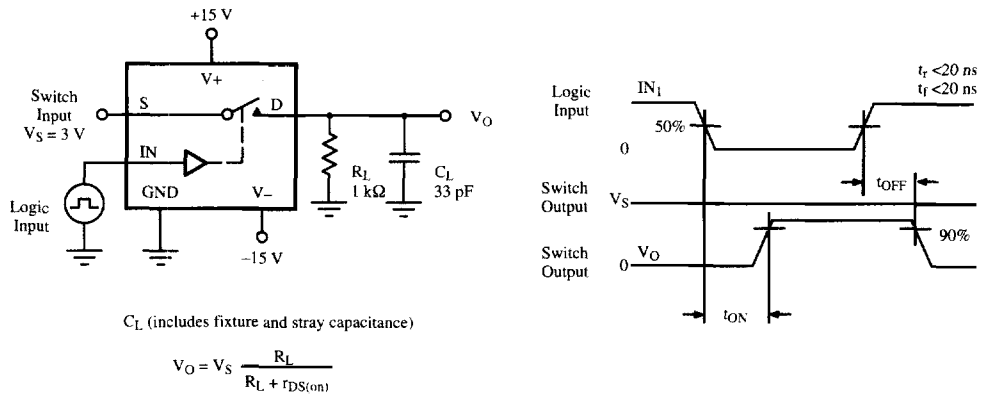

Figure 2. Switching Time

Applications

Single Supply Operation

The DG308A and DG309 will switch positive analog signals while using a single positive supply. This will allow use in many applications where only one supply is available. The trade-offs or performance given up while using single supplies are: 1) increased $r_{DS(on)}$ and 2)

slower switching speed. As stated in the absolute maximum ratings section of the data sheet, the analog voltage should not go above or below the supply voltages which in single supply operation are V_+ and 0 V.