

LTC3601

1.5A, 15V, MONOLITHIC SYNCHRONOUS STEP-DOWN REGULATOR

DESCRIPTION

Demonstration circuit 1353 is a step-down converter, using the LTC3601 monolithic synchronous buck regulator. The DC1353A has a maximum input voltage 15V, and is capable of delivering up to 1.5A of output current at a minimum input voltage of 4V. The output voltage of the DC1353A can be set as low as 0.6V, the reference voltage of the LTC3601. At low load currents, the DC1353A operates in discontinuous mode, and during shutdown, it consumes less than 40 uA of quiescent current. In continuous mode operation, the DC1353A is a high efficiency circuit - over 80%. The DC1353A can track another voltage with

the LTC3601 track function. Because of the high switching frequency of the LTC3601, which is programmable up to 4 MHz, the DC1353A uses low profile surface mount components. All these features make the DC1353A an ideal circuit for use in Lithium-Ion Battery applications and distributed power systems. Gerber files for this circuit are available. Call the LTC Factory.

Design files for this circuit board are available. Call the LTC factory.

As Shipped Performance Summary

PARAMETER	CONDITIONS	VALUE
Minimum Input Voltage		4V
Maximum Input Voltage		15V
Run/Shutdown		GND = Shutdown
		V _{IN} = Run
Output Voltage Regulation	V _{IN} = 4V to 15V, I _{OUT} = 0A to 1.5A	1.2V ±4% (1.152V – 1.248V)
	V _{IN} = 4V to 15V, I _{OUT} = 0A to 1.5A	1.8V ±4% (1.728V – 1.872V)
	V _{IN} = 4.5V to 15V, I _{OUT} = 0A to 1.5A	3.3V ±4% (3.168V – 3.432V)
Typical Output Ripple Voltage	V _{IN} = 12V, V _{OUT} = 1.8V, I _{OUT} = 1.5A (20 MHz BW)	< 20mV _{p-p}
Burst Mode	V _{IN} = 12V, V _{OUT} = 1.8V	< 400 mA
Nominal Switching Frequency	R _T = 324k	1 MHz ± 20%

Table 1. Jumper Description

JUMPER	FUNCTION	RANGE/SETTING (DEFAULT)
JP1	Vout Setting.	1.2V
JP5	Tracking or Soft-Start (SS)	(SS) - TRACK
JP6	Mode: Forced Continuous Mode (FCM), Burst Mode, or External Synchronization (SYNC)	(FCM) – SYNC – Burst Mode
JP7	Run	(ON) - OFF
JP8	Frequency	(1 MHz) - 2 MHz
JP9	ITH: Compensation	INT – (EXT)

QUICK START PROCEDURE

Demonstration Circuit 1353 is easy to set up to evaluate the performance of the LTC3601. For proper measurement equipment configuration, set up the circuit according to the diagram in **Figure 1**. Before proceeding to test, insert shunts into the 1.2V position of the output voltage header JP1, into the SS (soft-start) position of Track/SS header JP5, into the FCM (Forced Continuous Mode) position of MODE header JP6, into the OFF position of RUN header JP7, into the 1 MHz position of FREQ header JP8, and into the EXT position of ITH header JP9.

When measuring the input or output voltage ripple, care must be taken to avoid a long ground lead on the oscilloscope probe. Measure the input or output voltage ripple by touching the probe tip directly across the Vin or Vout and GND terminals. See **Figure 2** for proper scope probe measurement technique.

With the DC1353 set up according to the proper measurement configuration and equipment in **Figure 1**, apply 6.3V at Vin (Do not hot-plug Vin or increase Vin over the rated maximum supply voltage of 15V, or the part may be damaged.). Measure Vout; it should read 0V. Turn on the circuit by inserting the shunt in header JP7 into the ON position. The output voltage should be regulating. Measure Vout - it should measure 1.2V +/- 2% (1.176V to 1.224V).

Vary the input voltage from 4V to 15V and adjust the load current from 0 to 1.5A. Vout should set the input voltage to 15V and the output current to 1.5A. Measure the output ripple voltage; it should measure less than 20 mVAC.

Observe the voltage waveform at the switch pins (the other side of the inductor from the output). Verify the switching frequency is between 800 kHz and 1.2 MHz ($T = 1.25 \mu\text{s}$ and $0.833 \mu\text{s}$), and that the switch node waveform is rectangular in shape.

Change the JP6 shunt from forced continuous mode to Burst Mode. Also set the input voltage to 12V and the output current to any current less than 400 mA. Observe the discontinuous mode of operation at the switch node, and measure the output ripple voltage. It should measure less than 150 mV.

Insert the JP7 shunt into the OFF position and move the shunt in the 1.2V output JP1 header into any of the two remaining output voltage option headers: 1.8V (JP2) or 3.3V (JP3). Just as in the 1.2V Vout test, the output voltage should read Vout +/- 2% tolerance under static line and load conditions and +/- 1% tolerance under dynamic line and load conditions (+/- 2% total). Also, the circuit operation in discontinuous mode will be the same.

When finished, turn off the circuit by inserting the shunt in header JP7 into the OFF position.

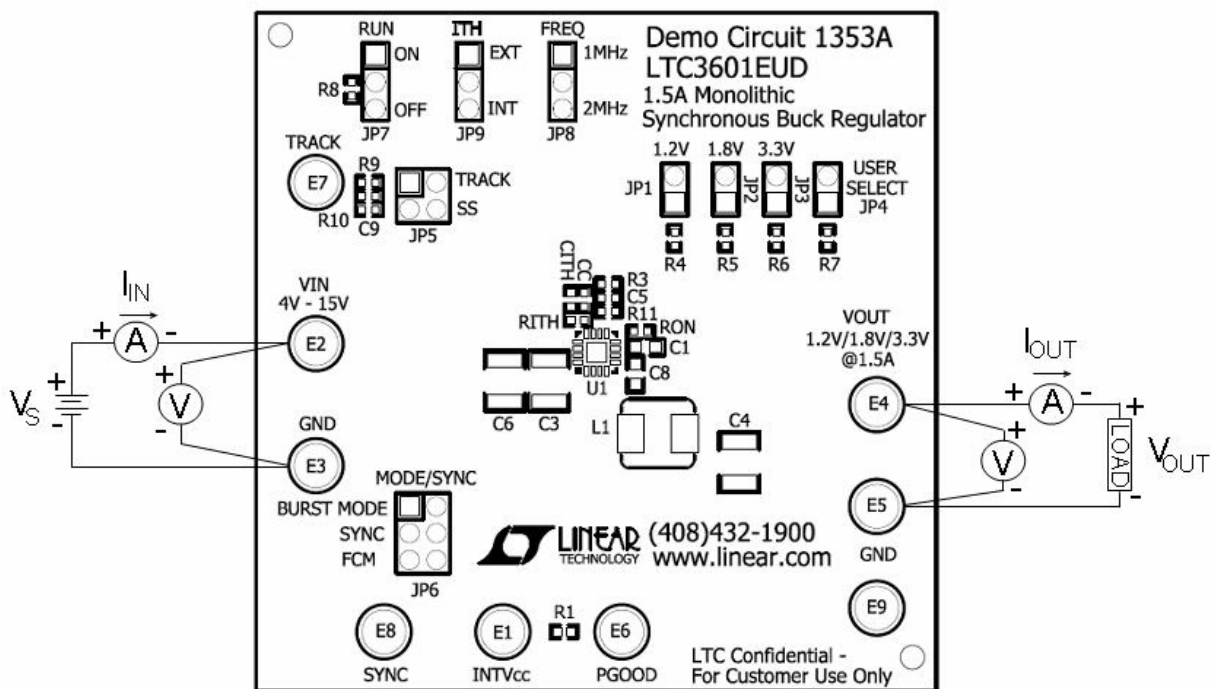

Figure 1. Proper Equipment Measurement Set-Up

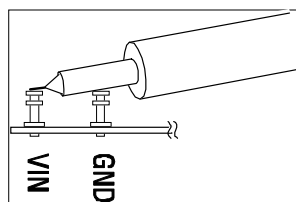

Figure 2. Measuring Input or Output Ripple

Normal Switching Frequency & Output Ripple Voltage Waveforms

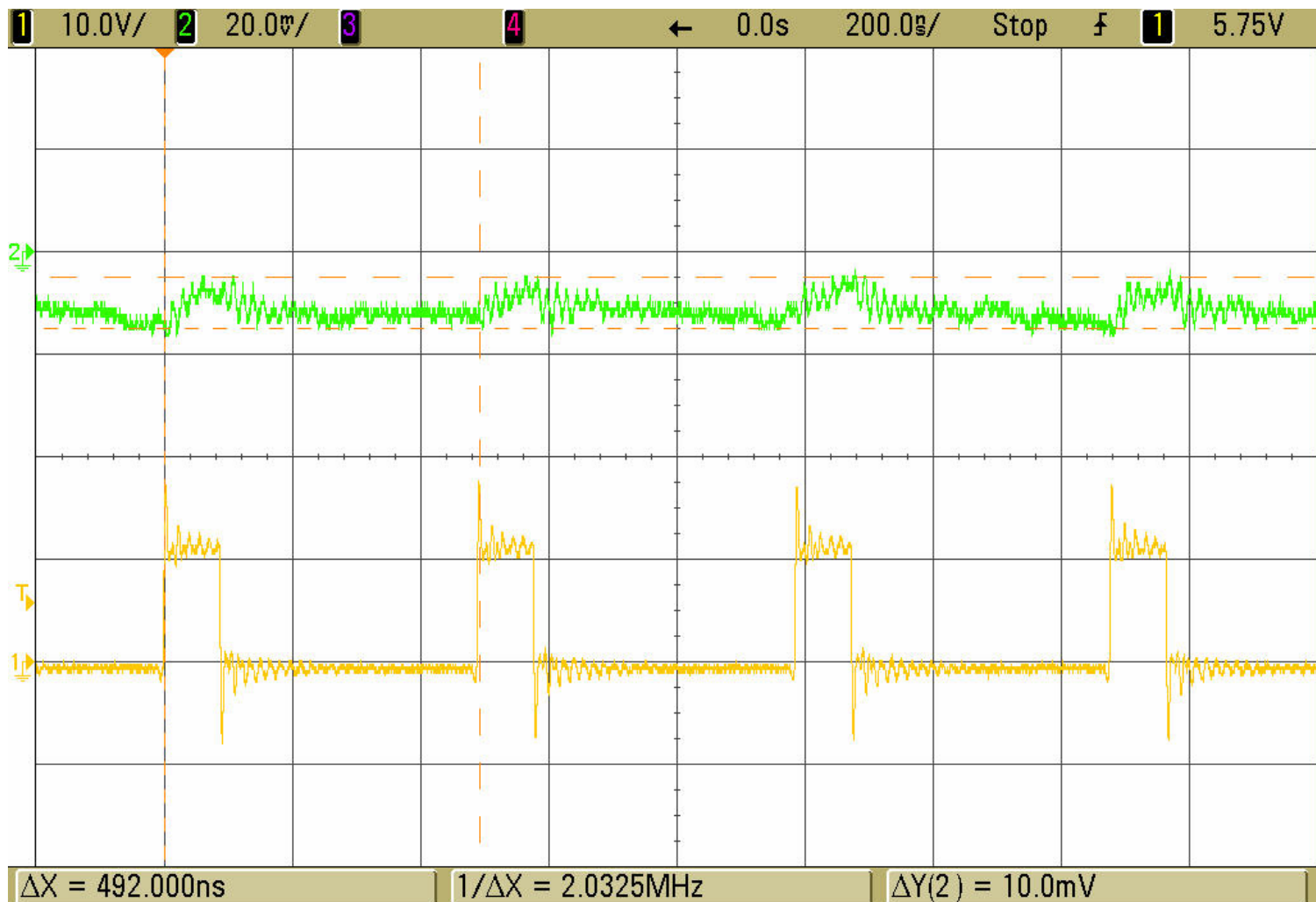

Figure 3. Switch Node & Output Ripple Voltage Waveforms

$V_{\text{IN}} = 12\text{V}$, $V_{\text{OUT}} = 1.8\text{V}$, $I_{\text{OUT}} = 1.5\text{A}$, $F_{\text{SW}} = 2\text{MHz}$

Trace 2: Output Ripple Voltage (20 mV/div AC)

Trace 1: Switch Voltage (10 V/div)

Load Step Response Waveform

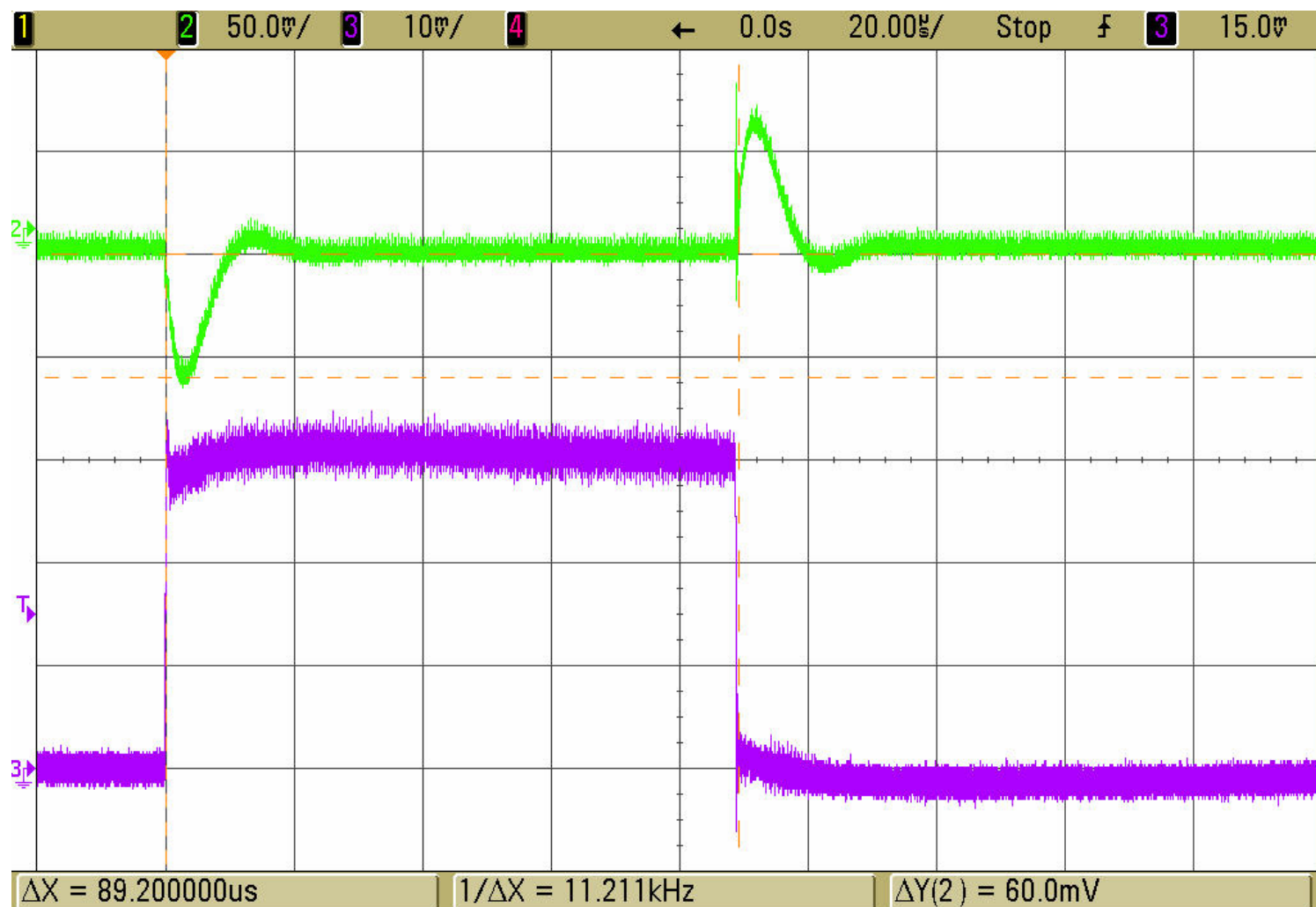

Figure 4. Load Step Response

$V_{IN} = 12\text{V}$, $V_{OUT} = 1.8\text{V}$, 1.5A Load Step (0A \leftrightarrow 1.5A)

Forced Continuous Mode $F_{SW} = 2\text{MHz}$

Trace 2: Output Voltage (50mV/div AC)

Trace 3: Output Current (0.5A/div)

REVISION HISTORY			
REVISION #	DESCRIPTION	DATE	APPROVED
0	0	0	0
1	1st Release	05/26/09	T. Gross
2			

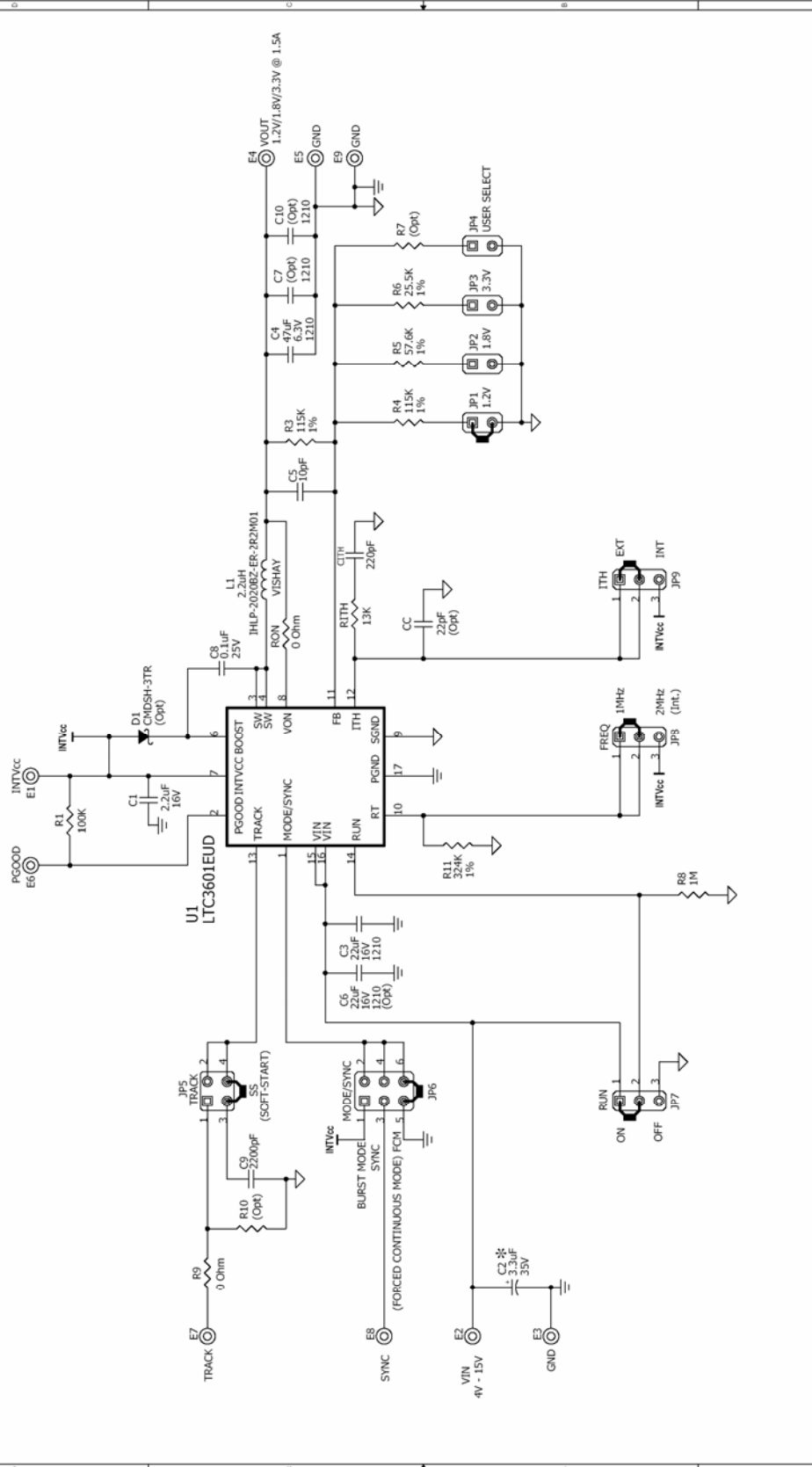

APPROVALS	
DRAWN BY: Ruddy Baucalis	www.linear.com
ENGINEER: Tom Gross	MLPITAS, CA, 95035
APPROVED:	(408)432-1900
CHECKED:	(408)434-6507 (FAX)
Docu: LTC3601EUD	Title: LTC3601EUD
Docu: 1353A	Docu: 1353A
Docu: Synchronous Buck Regulator	Docu: Synchronous Buck Regulator
Docu: Demo Circuit 1353A	Docu: Demo Circuit 1353A
Docu: SD	Docu: SD
Docu: 1 of 1	Docu: 1 of 1

This circuit is proprietary to Linear Technology and supplied for use with Linear Technology parts. While we make a best effort to ensure that our designs meet our published specifications, we do not warrant or assume any responsibility for the proper and reliable operation in the actual application. Component substitution and printed circuit board layout may significantly affect circuit performance or reliability. Contact Linear Applications Engineering for assistance.

* C2 IS AN OPTIONAL CAPACITOR. IT IS INSERTED ON THE DC1353A TO DAMPEN THE (POSSIBLE) RINGING VOLTAGE DUE TO THE LONG INPUT LEADS. ON A NORMAL, TYPICAL PCB, WITH SHORT TRACES, THE CAPACITOR IS NOT NEEDED.