



FEATURES:

- Super wide 6:1 Input range
- Extremely High Input range up to 1500VDC
- High I/O Isolation of 4000VDC and 4000VAC
- Over current and Over Voltage protection
- No minimum load required
- High efficiency of up to 84%
- Under Voltage Input protection
- Reversed connection protection



Models
Single output

Model	Input Voltage (V)	Output Voltage (V)	Output Current max (A)	Isolation (VDC)	Max Capacitive Load(uF)	Efficiency (200VDC) (%)
AM40W-60012S-NZ ‡	200-1200	12	3.33	4000	1200	83
AM40W-60015S-NZ ‡	200-1200	15	2.67	4000	1000	84
AM40W-60024S-NZ ‡	200-1200	24	1.67	4000	680	84
AM40W-80012S-NZ ‡‡	200-1500	12	3.33	4000*	3000	78**
AM40W-80015S-NZ ‡‡	200-1500	15	2.67	4000*	1500	82**
AM40W-80024S-NZ ‡‡	200-1500	24	1.67	4000*	680	83**

* VAC I/O Isolation

** Measured at 800VDC nominal input.

‡ For 600VDC input models add suffix “-ST” for optional screw terminal bottom plate or “-STD” for optional DIN Rail screw terminal bottom plate.

‡‡ For 800VDC input models add suffix “-ST” for optional DIN Rail screw terminal bottom plate with fuse and incorporated EMC filter or “-STS” for an optional DIN Rail screw terminal bottom plate only.

NOTE: All specifications in this datasheet are measured at an ambient temperature of 25°C, humidity<75%, nominal input voltage and at rated output load unless otherwise specified.

Input Specifications

Parameters	Conditions	Typical	Maximum	Units
Voltage range	600VDC		200-1200	VDC
	800VDC		200-1500	VDC
Input Current	600VDC input models, 200VDC		320	mA
	600VDC input models, 600VDC		100	mA
	600VDC input models, 1200VDC		55	mA
	800VDC input models, 200VDC		320	mA
	800VDC input models, 800VDC		80	mA
	800VDC input models, 1500VDC		42	mA
Inrush current <2ms	600VDC input models, 600VDC	60		A
	800VDC input models, 200VDC	50		A
	800VDC input models, 1500VDC	150		A
External fuse	600VDC input models, Slow blow		4A/1500VDC	
	800VDC input models, Slow blow		4A/1500VDC	
Input under voltage protection	600VDC input models, protection ON	175-185		VDC
	800VDC input models, protection OFF	185-195		VDC
	800VDC input models, protection ON	170-185		VDC
	800VDC input models, protection OFF	180-195		VDC
Startup time*	800VDC input models, 100% load, LL-HL		3	s

* Power loss recovery time: 15s

Isolation Specifications

Parameters	Conditions	Typical	Maximum	Units
Tested I/O voltage	600VDC input models, 1 min	4000		VDC
Tested I/O voltage	800VDC input models, 1 min	4000		VAC

Output Specifications

Parameters	Conditions	Typical	Maximum	Units
Voltage accuracy	600VDC input models	±1	±2	%
	800VDC input models	±2		%
Line voltage regulation	600VDC input models	±0.5	±1	%
	800VDC input models	±1		%
Load voltage regulation	600VDC input models	±0.5	±1	%
	800VDC input models	±1		%
Over voltage protection	600VDC input models, voltage clamp			
	AM40W-80012S-NZ		20	VDC
	AM40W-80015S-NZ		20	VDC
	AM40W-80024S-NZ		30	VDC
Over current protection	600VDC input models	≥110		% of I _{out}
	800VDC input models	≥120		% of I _{out}
Short Circuit protection	Continuous			
Short circuit restart	Auto recovery			
Temperature coefficient		±0.02		%/°C
Ripple & Noise	20MHz Bandwidth, 600VDC input models	100	200	mV p-p
	20MHz Bandwidth, 800VDC input models	150	300	mV p-p
Hold up time	600VDC	5		ms

General Specifications

Parameters	Conditions	Typical	Maximum	Units
Switching frequency	100% load	65		KHz
Operating temperature	600VDC input models, derating above 50°C	-25 to 70		°C
	800VDC input models, see derating curve	-40 to 70		°C
Derating	600VDC input models, +50 to +70°C	3		%/°C
	800VDC input models, 200-300VDC, -40°C to 0°C	1.5		%/°C
	800VDC input models, +50°C to +70°C	2.5		%/°C
	800VDC input models, 1200-1500VDC	2.5		%/VDC
	800VDC input models, 2000m-5000m	6.7		%/km
Storage temperature	600VDC input models	-25 to 85		°C
	800VDC input models	-40 to 85		°C
Cooling	Natural convection			
Humidity			95	% RH
Case material	Black plastic (UL94-V0)			
Weight	600VDC input models, pin mountable	210		g
	600VDC input models, -ST mounting plate	295		g
	600VDC input models, -STD mounting plate	360		g
	800VDC input models, pin mountable	434		g
	800VDC input models, -ST mounting plate	744		g
	800VDC input models, -STS mounting plate	494		g
Dimensions (L x W x H)	600VDC input models, pin mountable	3.50 x 2.50 x 0.98inches, 89.0 x 63.5 x 25.0mm		
	600VDC input models, -ST mounting plate	5.31 x 2.76 x 1.32inches, 135.0 x 70.0 x 33.5mm		
	600VDC input models, -STD mounting plate	5.31 x 2.76 x 1.54inches, 135.0 x 70.0 x 39.0mm		
	800VDC input models, pin mountable	4.92 x 2.95 x 1.58inches, 125.0 x 75.0 x 40.0mm		
	800VDC input models, -ST mounting plate	5.75 x 5.43 x 2.17inches, 146.0 x 138.0 x 55.0mm		
	800VDC input models, -STS mounting plate	5.08 x 4.29 x 1.93inches, 129.0 x 109.0 x 49.0mm		
MTBF	>300,000 hrs (MIL-HDBK -217F, Ground Benign, t=+25°C)			
Soldering temperature	Manual soldering, duration 3 to 5 sec	360		°C
	Wave soldering, duration 5 to 10 sec	260		°C

Safety Specifications

Parameters		
Approvals	CE (for 800Vin models only)	
Standards	Design to meet CSA-C22.2 No.107.1-01, UL 1741, EN62109 (for 800Vin models only)	
	EMI - Conducted and radiated emission	EN55032, class A (with the recommended EMC circuit)
	Electrostatic Discharge Immunity	IEC 61000-4-2: Contact $\pm 6\text{KV}$ /Air $\pm 8\text{KV}$, Criteria B
	RF, Electromagnetic Field Immunity	IEC 61000-4-3: 10V/m, Criteria A
	Electrical Fast Transient/Burst Immunity (600Vin)	IEC 61000-4-4: $\pm 4\text{KV}$, Criteria B (with the recommended EMC circuit)
	Electrical Fast Transient/Burst Immunity (800Vin)	IEC 61000-4-4: $\pm 2\text{KV}$, Criteria B (with the recommended EMC circuit)
	Surge Immunity (600VDC Vin)	IEC 61000-4-5: $\pm 2\text{KV}$, Criteria B (with the recommended EMC circuit)
	Surge Immunity (800VDC Vin)	IEC 61000-4-5: $\pm 1\text{KV}$, Criteria B (with the recommended EMC circuit)
	RF, Conducted Disturbance Immunity	IEC 61000-4-6: 10Vrms, Criteria A
	Power frequency Magnetic Field Immunity	IEC 61000-4-8: 10A/m, Criteria A
Voltage dips, Short Interruptions Immunity (600Vin)	IEC 61000-4-29: 0-70%, Criteria B	

*800VDC input models with -ST option do not require additional circuit to meet above standards.

Dimensions

600VDC Input models

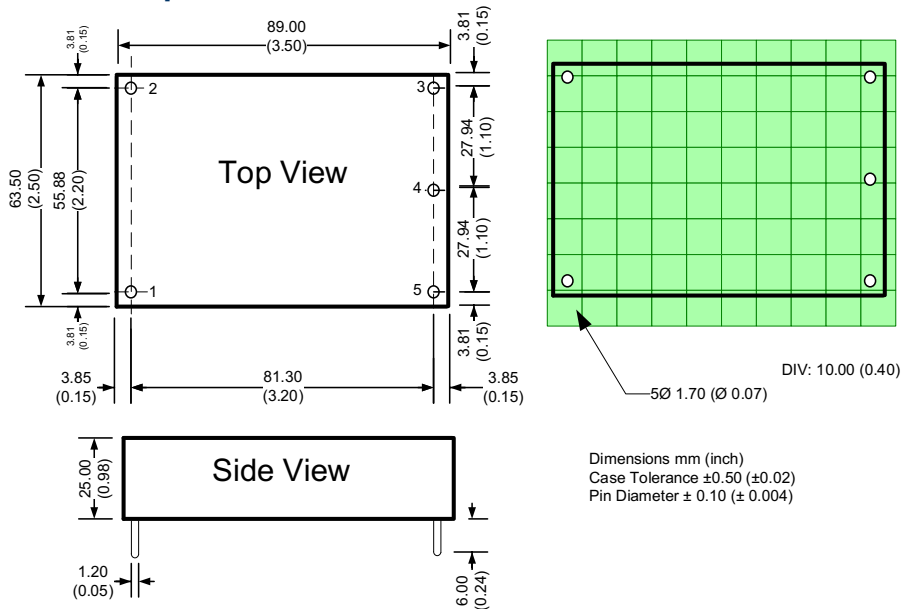

Pin Out Specifications

Pin	600VDC Input
1	+Vin
2	-Vin
3	+Vout
4	-Vout
5	N.C.

600VDC input models with optional -ST bottom plate

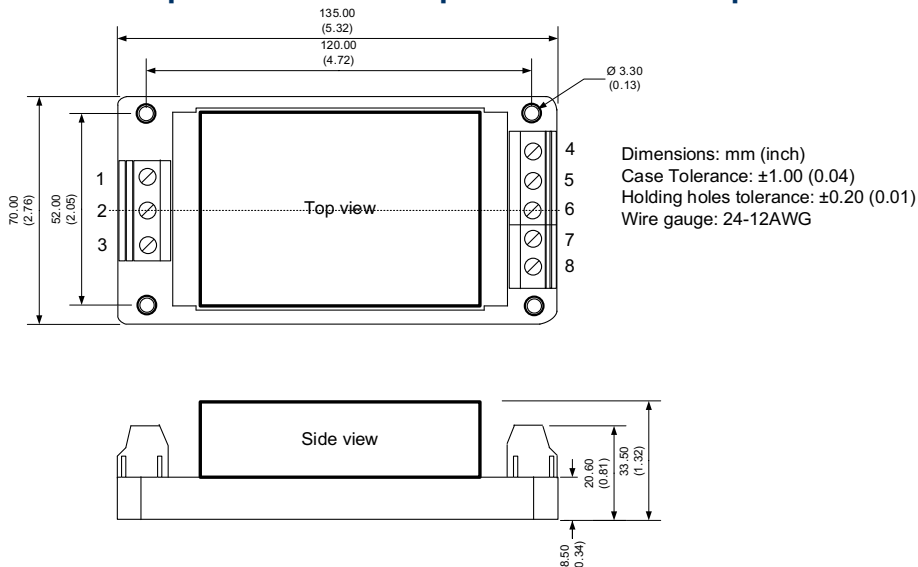

Pin Out Specifications

Pin	Single
1	-Vin
2	N.C.
3	+Vin
4	+Vout
5	N.C.
6	-Vout
7	N.C.
8	N.C.

600VDC input models with optional -STD bottom plate

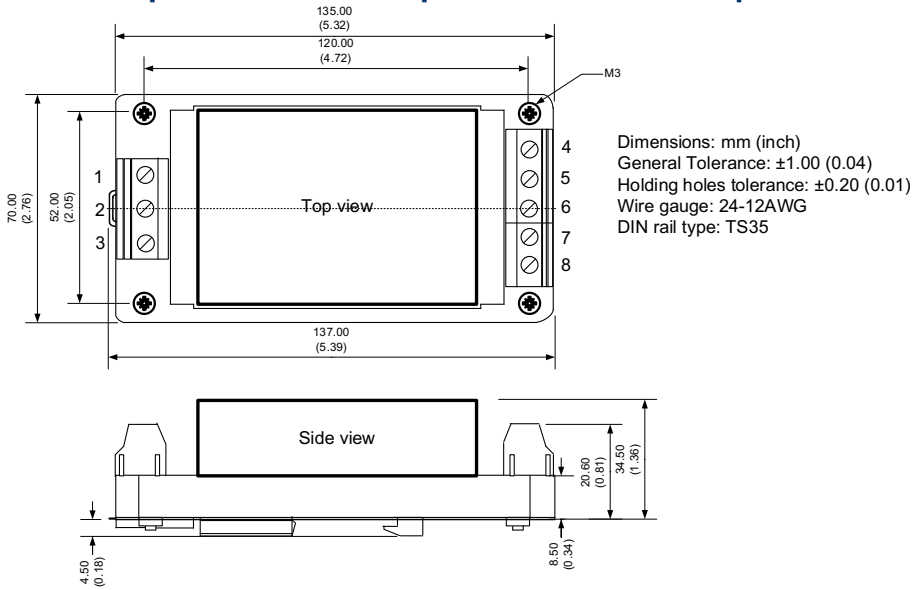

Pin Out Specifications

Pin	Single
1	-Vin
2	N.C.
3	+Vin
4	+Vout
5	N.C.
6	-Vout
7	N.C.
8	N.C.

800VDC input models

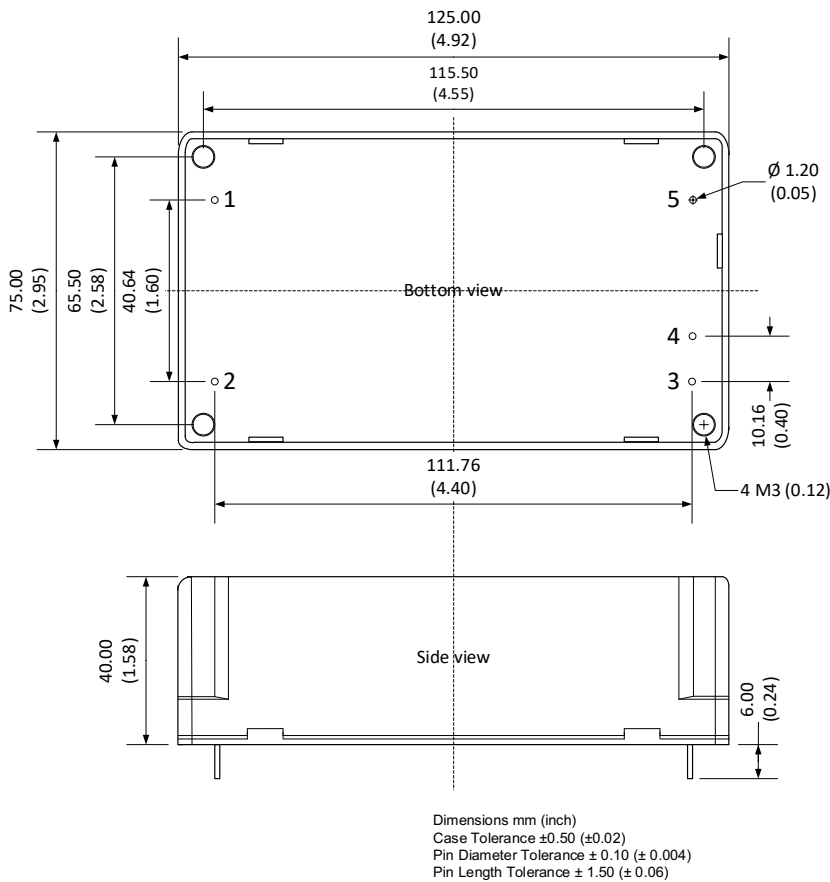

Pin Out Specifications

Pin	800VDC Input
1	+Vin
2	-Vin
3	+Vout
4	-Vout
5	N.C.

800VDC input models with optional -ST bottom plate

Pin Out Specifications

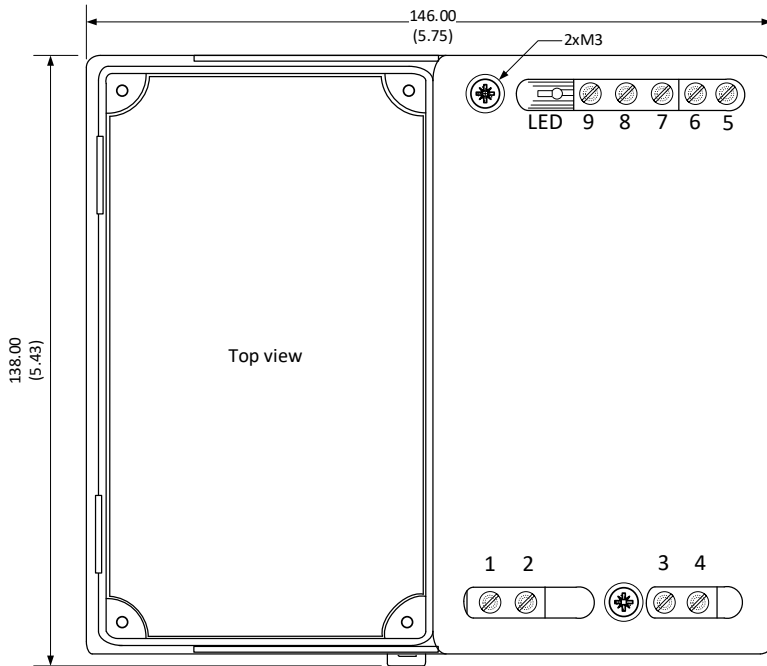

Pin	Single
1	-Vin
2	-Vin
3	+Vin
4	+Vin
5	+Vout
6	-Vout
7	N.C.
8	N.C.
9	N.C.

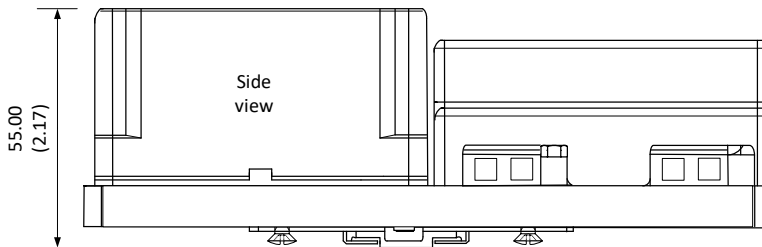

Dimensions mm (inch)
Installed on DIN rail type TS35
Wire: 24-12AWG
Case Tolerance ± 0.50 (± 0.02)
General Tolerance ± 1.00 (± 0.04)

NOTES:

1. To replace the internal fuse in the models with suffix "-ST", unscrew the 2 screws on the top side of the plate.
2. DIN rail metal holder needs to be grounded.
3. Horizontal mounting recommended.

800VDC input models with optional -STS bottom plate

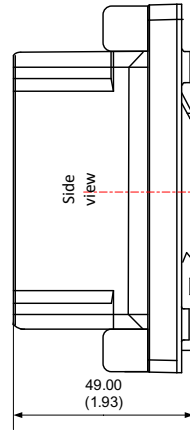
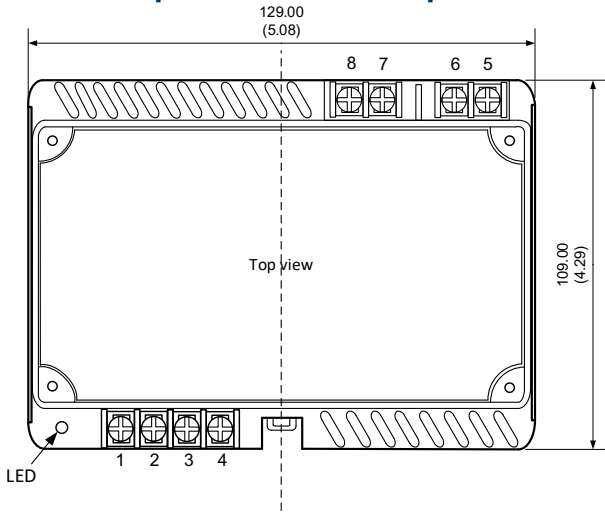

Pin Out Specifications

Pin	Single
1	+V out
2	+V out
3	-V out
4	-V out
5	+V in
6	+V in
7	-V in
8	-V in

Dimensions mm (inch)
Installed on DIN rail type TS35
Wire: 24-12AWG
Tightening torque 0.4N-m max.
General Tolerance ± 1.00 (± 0.04)

Derating
600VDC input models

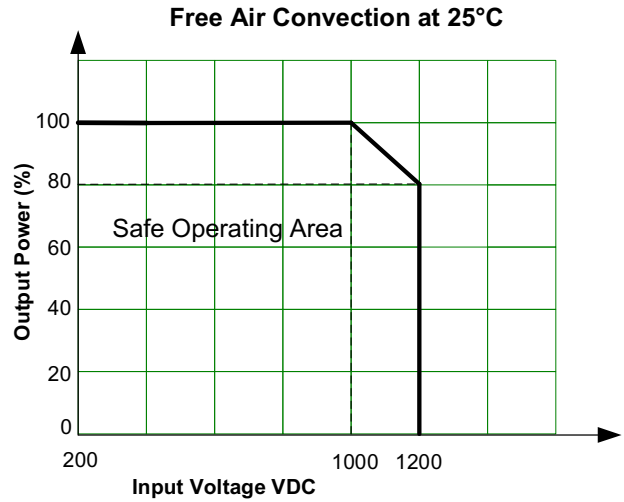
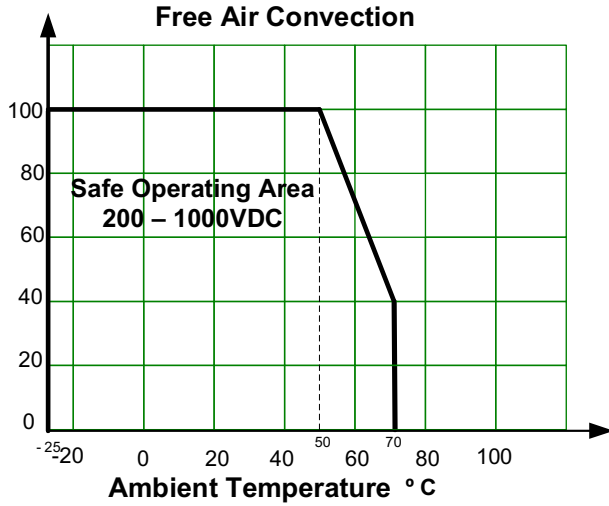

800VDC input models

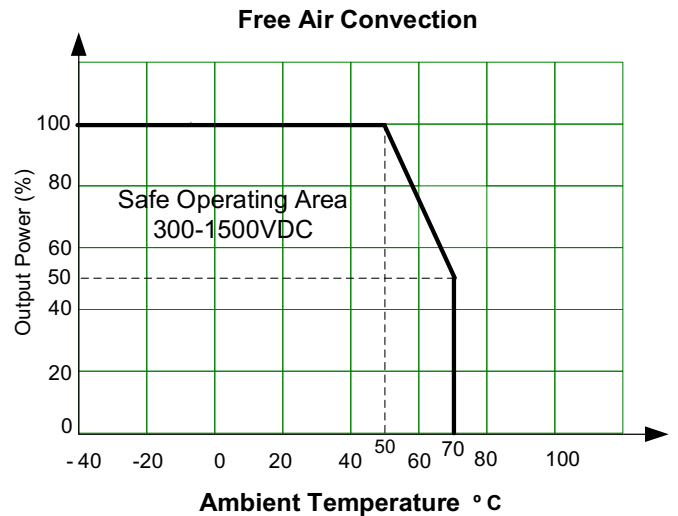
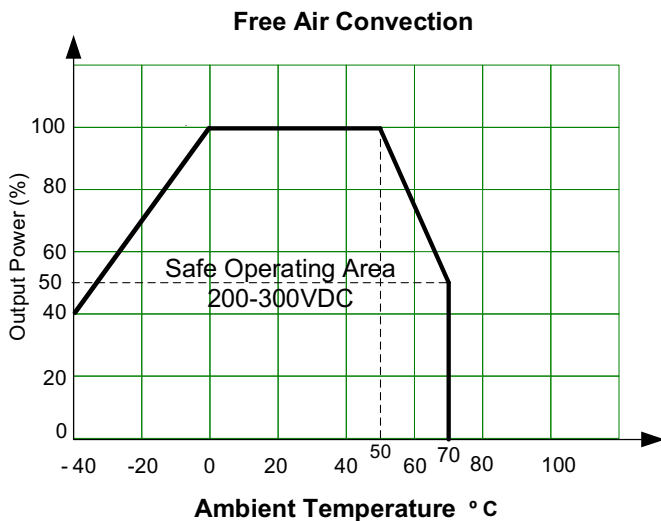

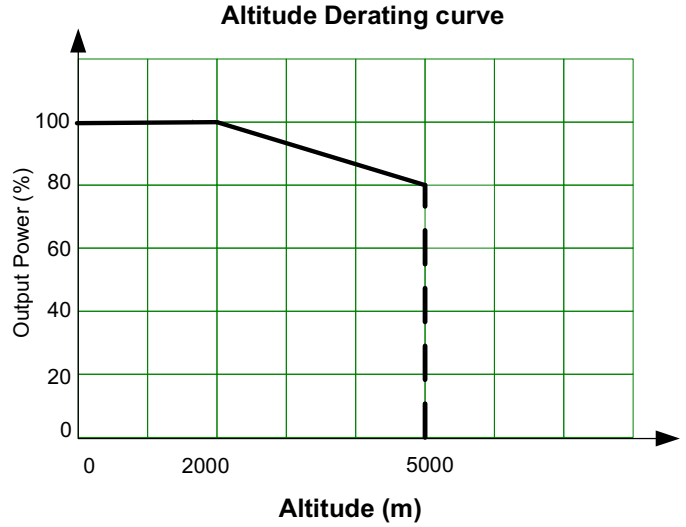
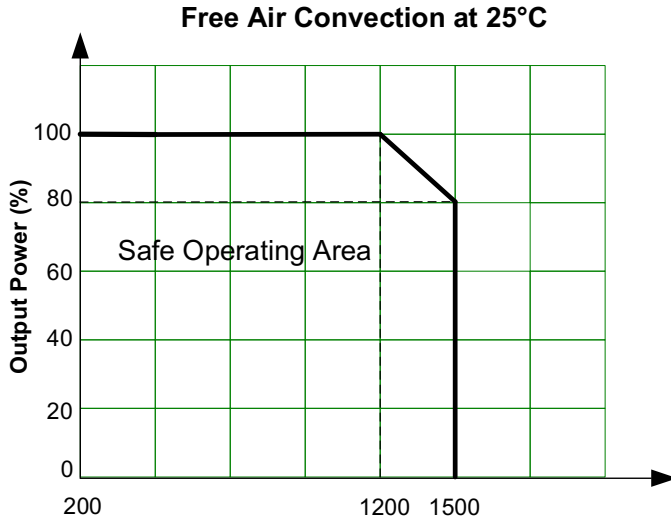

Typical Application circuit

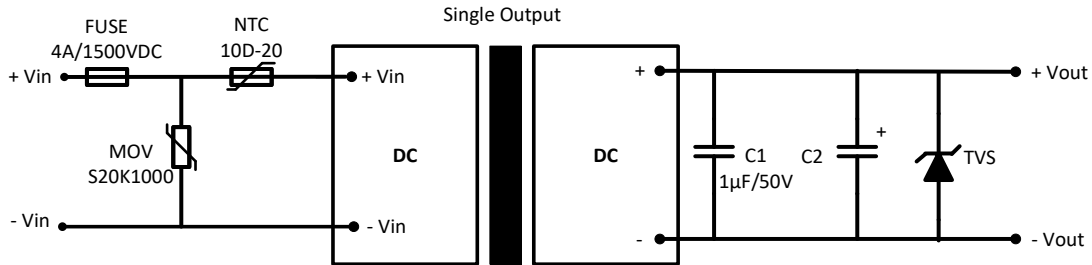

Model	C2	TVS
600VDC input models, 12 & 15 Vout	220 µF	20V
600VDC input models, 24 Vout	120 µF	30V
800VDC input models, 12 & 15 Vout	120 µF	20V
800VDC input models, 24 Vout	68 µF	30V

***NOTE:**
For 800VDC Input models NTC and MOV are not needed.
For 800VDC input models with suffix "-ST" this external circuit is not needed.
Choose capacitors with at least 20% voltage rating margin.

Recommended EMC Circuit

600VDC input models

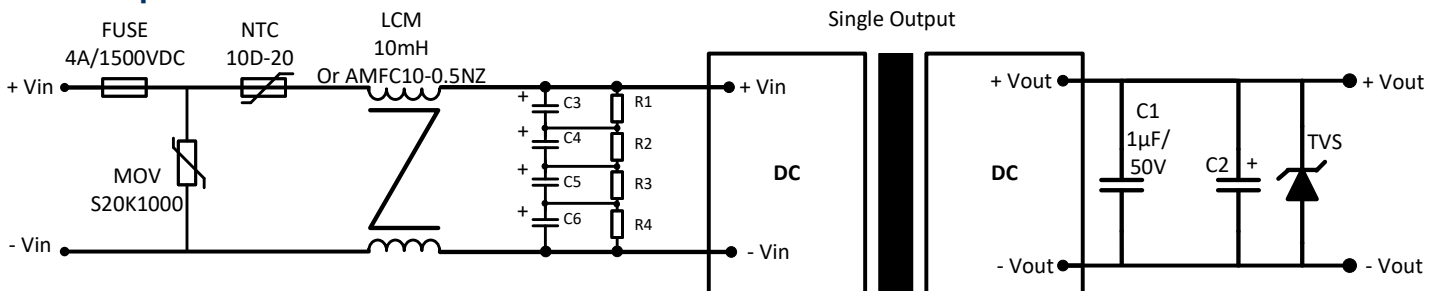

Model	C3, C4, C5 & C6	R1, R2, R3 & R4
600VDC input models	47 µF/450V	1MΩ / 2W

800VDC input models

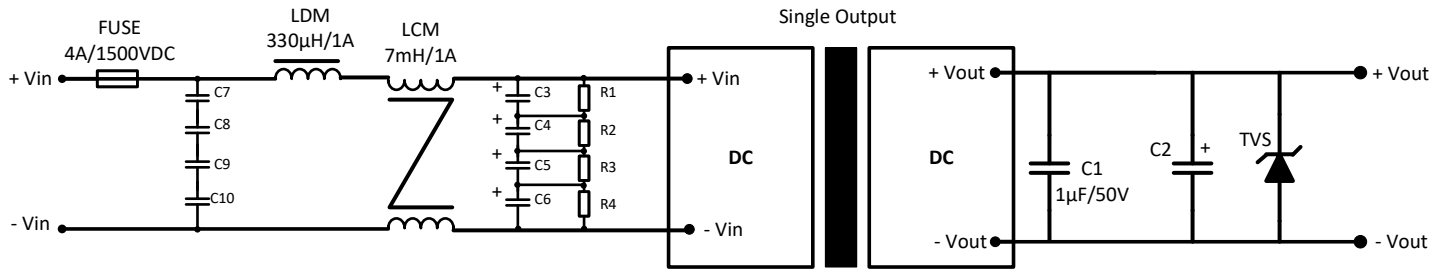

Model	C3, C4 C5 & C6	C7, C8, C9 & C10	R1, R2, R3 & R4
800VDC input models	47 µF/450V	100 nF/275VAC	1MΩ / 2W

*** NOTE:** For 800VDC input models with suffix “-ST” option this external EMC circuit is not needed.

NOTE: 1. Datasheets are updated as needed and as such, specifications are subject to change without notice. Once printed or downloaded, datasheets are no longer controlled by Aimtec; refer to www.aimtec.com for the most current product specifications. 2. Product labels shown, including safety agency certifications on labels, may vary based on the date manufactured. 3. Mechanical drawings and specifications are for reference only. 4. All specifications are measured at an ambient temperature of 25°C, humidity<75%, nominal input voltage and at rated output load unless otherwise specified. 5. Aimtec may not have conducted destructive testing or chemical analysis on all internal components and chemicals at the time of publishing this document. CAS numbers and other limited information are considered proprietary and may not be available for release. 6. This product is not designed for use in critical life support systems, equipment used in hazardous environments, nuclear control systems or other such applications which necessitate specific safety and regulatory standards other the ones listed in this datasheet. 7. Warranty is in accordance with Aimtec’s standard Terms of Sale available at www.aimtec.com.