

- 1
- 2
- 3
- 4
- 5
- 6
- 7
- 8
- 9
- 10
- 11
- 12
- 13
- 14
- 15
- 16
- 17
- 18

LEVER BODY

Glass-fibre reinforced polyamide based (PA) technopolymer, grey-black colour, matte finish.

PUSH BUTTON

Technopolymer in grey-black or orange colours, glossy finish.

STANDARD EXECUTIONS

Glass-fibre reinforced technopolymer clamping element with retaining pin, black colour, with knurling on the protruding part to make initial tightening easier. AISI 302 stainless steel return spring.

- **MRT-B:** brass boss, threaded blind hole.
- **MRT-SST:** AISI 303 stainless steel boss, threaded blind hole.
- **MRT-p:** zinc-plated steel threaded stud, chamfered flat end UNI 947 : ISO 4753 (see Technical data on page A-10).
- **MRT-SST-p:** AISI 303 stainless steel threaded stud, chamfered flat end UNI 947 : ISO 4753 (see Technical data on page A-10).

FEATURES AND APPLICATIONS

Flat adjustable handle, open configuration to avoid any deposit of unhygienic residues or scraps and dirt.

Particularly suitable when the lever turning angle is limited owing to lack of space.

Compared to other types of adjustable handles with metal retaining screw this solution offers:

- absolute electric insulation for the operator
- no visible steel parts subject to rust
- more comfortable lever release.

STRESS RESISTANCE

See ERX. page 324.

INSTRUCTIONS OF USE

For clamping, lift the lever to disengage the clamping device teeth and bring it back to start position. By releasing the lever, the return spring automatically engages the teeth.



MRT-B
MRT-SST

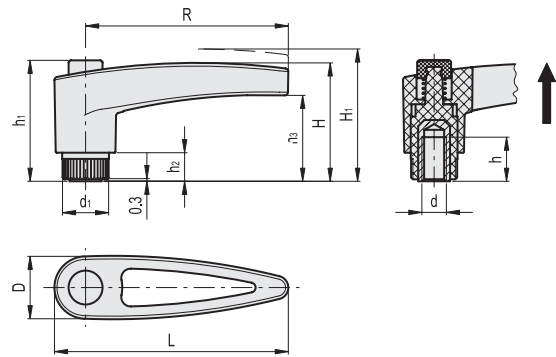

Conversion Table	
1 mm = 0.039 inch	
R	
mm	inch
43	1.69
64.5	2.54
79.5	3.13

*Complete with colour index, example: 140111-C1 MRT.42-B-M5-C1

C1
RAL7021

C2
RAL2004

MRT-B

Code	Description	R	d6H	L	D	H	H1	h	h1	h2	h3	d1	Teeth no.	
140111-*	MRT.42-B-M5-*	43	M5	51	16	28	31.5	10	29	6	21.5	12	18	10
140112-*	MRT.42-B-M6-*	43	M6	51	16	28	31.5	10	29	6	21.5	12	18	9
140121-*	MRT.65-B-M6-*	64.5	M6	74.5	20	37	41	12	38	9	27	15	20	21
140122-*	MRT.65-B-M8-*	64.5	M8	74.5	20	37	41	13	38	9	27	15	20	22
140131-*	MRT.80-B-M8-*	79.5	M8	92	25	45	49	20	47	11	34.5	18.5	24	41
140132-*	MRT.80-B-M10-*	79.5	M10	92	25	45	49	18	47	11	34.5	18.5	24	40
140133-*	MRT.80-B-M12-*	79.5	M12	92	25	45	49	17	47	11	34.5	18.5	24	39

MRT-SST

Code	Description	R	d6H	L	D	H	H1	h	h1	h2	h3	d1	Teeth no.	
140616-*	MRT.42-SST-M6-*	43	M6	51	16	28	31.5	10	29	6	21.5	12	18	9
140622-*	MRT.65-SST-M8-*	64.5	M8	74.5	20	37	41	13	38	9	27	15	20	22
140626-*	MRT.80-SST-M10-*	79.5	M10	92	25	45	49	17	47	11	34.5	18.5	24	40

Clamping levers

MRT-p
MRT-SST-p

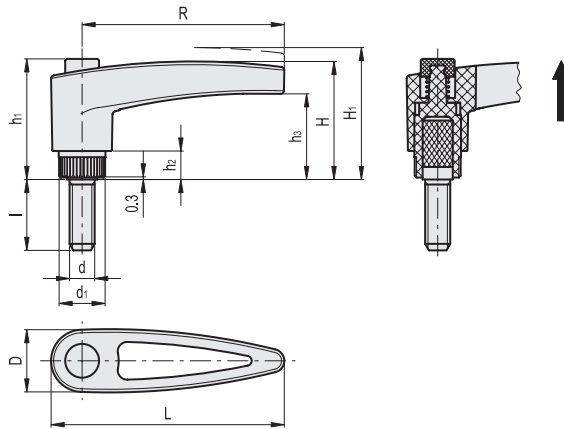

Conversion Table	
1 mm = 0.039 inch	
R	
mm	inch
43	1.69
64.5	2.54
79.5	3.13

MRT-p

METRIC

Code	Description	R	d6g	L	D	H	H1	h1	h2	h3	d1	l	Teeth no.	⚖
140291-*	MRT.42-p-M4x10-*	43	M4	51	16	28	31.5	29	6	21.5	12	10	18	9
140303-*	MRT.42-p-M5x20-*	43	M5	51	16	28	31.5	29	6	21.5	12	20	18	12
140311-*	MRT.42-p-M6x10-*	43	M6	51	16	28	31.5	29	6	21.5	12	10	18	12
140312-*	MRT.42-p-M6x16-*	43	M6	51	16	28	31.5	29	6	21.5	12	16	18	13
140313-*	MRT.42-p-M6x20-*	43	M6	51	16	28	31.5	29	6	21.5	12	20	18	14
140315-*	MRT.42-p-M6x30-*	43	M6	51	16	28	31.5	29	6	21.5	12	30	18	16
140351-*	MRT.65-p-M8x16-*	64.5	M8	74.5	20	37	41	38	9	27	15	16	20	31
140352-*	MRT.65-p-M8x20-*	64.5	M8	74.5	20	37	41	38	9	27	15	20	20	32
140353-*	MRT.65-p-M8x25-*	64.5	M8	74.5	20	37	41	38	9	27	15	25	20	33
140354-*	MRT.65-p-M8x30-*	64.5	M8	74.5	20	37	41	38	9	27	15	30	20	34
140356-*	MRT.65-p-M8x40-*	64.5	M8	74.5	20	37	41	38	9	27	15	40	20	37
140381-*	MRT.80-p-M10x20-*	79.5	M10	92	25	45	49	47	11	34.5	18.5	20	24	54
140383-*	MRT.80-p-M10x30-*	79.5	M10	92	25	45	49	47	11	34.5	18.5	30	24	57
140385-*	MRT.80-p-M10x40-*	79.5	M10	92	25	45	49	47	11	34.5	18.5	40	24	60
140386-*	MRT.80-p-M10x50-*	79.5	M10	92	25	45	49	47	11	34.5	18.5	50	24	63
140403-*	MRT.80-p-M12x30-*	79.5	M12	92	25	45	49	47	11	34.5	18.5	30	24	58
140407-*	MRT.80-p-M12x50-*	79.5	M12	92	25	45	49	47	11	34.5	18.5	50	24	65

MRT-SST-p

INOX STAINLESS STEEL METRIC

Code	Description	R	d6g	L	D	H	H1	h1	h2	h3	d1	l	Teeth no.	⚖
140671-*	MRT.42-SST-p-M6x16-*	43	M6	51	16	28	31.5	29	6	21.5	12	16	18	13
140672-*	MRT.42-SST-p-M6x20-*	43	M6	51	16	28	31.5	29	6	21.5	12	20	18	14
140674-*	MRT.42-SST-p-M6x30-*	43	M6	51	16	28	31.5	29	6	21.5	12	30	18	16
140691-*	MRT.65-SST-p-M8x16-*	64.5	M8	74.5	20	37	41	38	9	27	15	16	20	31
140692-*	MRT.65-SST-p-M8x20-*	64.5	M8	74.5	20	37	41	38	9	27	15	20	20	32
140694-*	MRT.65-SST-p-M8x30-*	64.5	M8	74.5	20	37	41	38	9	27	15	30	20	34
140695-*	MRT.65-SST-p-M8x40-*	64.5	M8	74.5	20	37	41	38	9	27	15	40	20	37
140701-*	MRT.80-SST-p-M10x20-*	79.5	M10	92	25	45	49	47	11	34.5	18.5	20	24	54
140702-*	MRT.80-SST-p-M10x30-*	79.5	M10	92	25	45	49	47	11	34.5	18.5	30	24	57
140703-*	MRT.80-SST-p-M10x40-*	79.5	M10	92	25	45	49	47	11	34.5	18.5	40	24	60



Clamping levers