

THIS COPY IS PROVIDED ON A RESTRICTED BASIS AND IS NOT TO BE USED IN ANY WAY DETRIMENTAL TO THE INTERESTS OF PANDUIT CORP.

PANDUIT PART NUMBER	STUD SIZE	DIMENSIONS - in [mm]				
		A ± .03 [0,8]	W ± .01 [0,3]	C ± .02 [0,5]	M ± .03 [0,8]	H ± .01 [0,3]
P8-8RN *	#8	1.09 [27,7]	.36 [9,1]	.43 [10,9]	.91 [23,1]	.17 [4,3]
P8-8R	#8	1.12 [28,5]	.42 [10,7]	.43 [10,9]	.91 [23,1]	.17 [4,3]
P8-10R	#10	1.14 [29,0]	.47 [11,9]	.43 [10,9]	.91 [23,1]	.20 [5,1]
P8-14R	1/4"	1.14 [29,0]	.47 [11,9]	.43 [10,9]	.91 [23,1]	.27 [6,9]
P8-56R	5/16"	1.25 [31,8]	.59 [15,0]	.51 [13,0]	.95 [24,1]	.33 [8,4]
P8-38R	3/8"	1.25 [31,8]	.59 [15,0]	.51 [13,0]	.95 [24,1]	.39 [9,9]
P8-12R	1/2"	1.36 [34,5]	.82 [20,8]	.54 [13,7]	.95 [24,1]	.52 [13,2]

*P8-8RN NOT CSA CERTIFIED

NOTES:

- UL LISTED AND CSA CERTIFIED FOR:
 - #8 AWG STRANDED COPPER WIRE
 - 302°F (150°C) MAX OPERATING TEMP
 - 2000 VOLTS MAX
- SEE WWW.PANDUIT.COM FOR PACKAGE QUANTITIES
- MATERIAL:
 - STAMPING - .040" [1,02] THK COPPER, TIN PLATED
- DIMENSIONS IN BRACKETS ARE IN MILLIMETERS
- WIRE STRIP LENGTH: $3/8" \begin{matrix} +1/32 \\ -0 \end{matrix} \begin{matrix} +0,8 \\ -0 \end{matrix} [9,5mm]$

UL & CSA TOOLS, DIES AND NUMBER OF CRIMPS		
TOOL	DIES	NUMBER OF CRIMPS
CT-1701	P8	2
CT-2600	CD-2600-P8	1

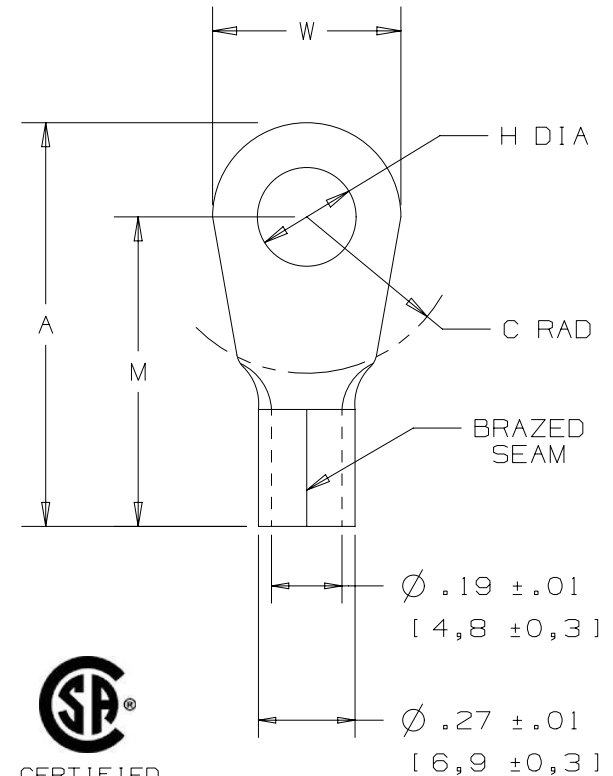

TITLE
 #8 BARREL NON-INSULATED RING TONGUE
 .280 [7.11] MAX. WIRE INSUL.
 DIAMETER
 CUSTOMER DRAWING

ITEM REVISION NAME	N41215BB/12	PANDUIT
DATASET FILE NAME	N41215BB/12	
UNLESS OTHERWISE SPECIFIED, DIMENSIONAL TOLERANCES ARE: IN [mm]		MATERIAL: SEE NOTES
$.x \pm$ $.xx \pm$ 		DRAWING NUMBER: A41215
DRAWN BY	DATE	SCALE
DAW		NONE
CHK		SHT 1 OF 1
APR		SIZE A

REV	DATE	BY	CHK	APR	DESCRIPTION	ECN
12	10/16/18	BWG	BJPU	JADE	REPLACED TABLE WITH NUMBER OF CRIMPS.	041687/00
11	5/17	JHNU	TMR	RGB	ADDED VOLTAGE RATING	N41215BB-A41215
10	07/15	TMR	TMR	RGB	ADDED CT-2600 TO PKG LABEL, CSA BACK TO DWG, UPDATED DIES	N41215BB-A41215
09	07/14	MBY	JHNU	RGB	REVISED NOTES, MOVED TOOLS TO TABLE, REVISED CERTIFICATION, UPDATED BORDER	N41215BB-A41215

D10100DA/16