

HANDLE SHANKS

Glass-fibre reinforced polyamide based (PA) technopolymer, black colour, matte finish. Supplied not assembled. The handle shank connection to the tube avoids tube rotation.

ANTI-ROTATION TUBE END PLUGS

NBR synthetic rubber.

STANDARD EXECUTIONS

Pass-through holes for cylindrical-head screws with hexagon socket. Two reference pins (to be fitted during handle assembly) guarantee an exact positioning of the shanks.

- **M.1043-EP**: aluminium tube, epoxy resin coating, metalflake graphite colour, matte finish. Highly resistant to wear, scratches and chemical agents. Avoid continuous and prolonged contact with boiling water or steam.

- **M.1043-AN**: anodised aluminium tube, natural colour.

- **M.1043-SST**: AISI 304 stainless steel tube.

Threaded blind holes. Two reference pins (to be fitted during handle assembly) guarantee an exact positioning of the shanks.

- **M.1043-BM-EP**: aluminium tube, epoxy resin coating, metalflake graphite colour, matte finish. Highly resistant to wear, scratches and chemical agents. Avoid continuous and prolonged contact with boiling water or steam.

- **M.1043 BM-AN**: anodised aluminium tube, natural colour.

- **M.1043-BM-SST**: AISI 304 stainless steel tube.

TECHNICAL DATA

Tensile stress: F2 values reported in the table are the result of breaking tests carried out with the appropriate dynamometric equipment under the test conditions shown in the figure with ambient temperature.

ACCESSORIES ON REQUEST

- DS-M.1043: spacer sleeves for side shank with connection for tube Ø30 in polyamide based (PA) technopolymer to increase the distance between the handle and the fitting surface (see table).

- SCM.: Intermediate shank for tube Ø20 and for tube Ø30 in polyester based (PBT) technopolymer, black colour, matte finish. Suggested for tube longer than 700 mm (see table).



ELESA Original design

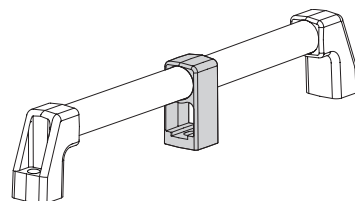
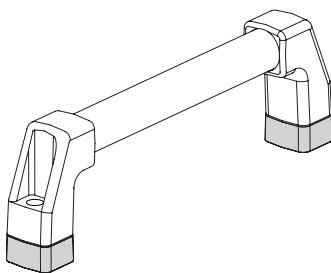
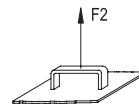

DS-M.1043

Code	Description	For handle	⚖️
15291	DS-M.1043/30-10	M.1043/20 M.1043 BM/20	18
15293	DS-M.1043/30-20	M.1043/30 M.1043 BM/30	28

SCM.

Code	Description	For handle	⚖️
15306	SCM.1043-20	M.1043/20 M.1043 BM/20	48
15305	SCM.1043-30	M.1043/30 M.1043 BM/30	51

M.1043-EP
M.1043-AN
M.1043-SST

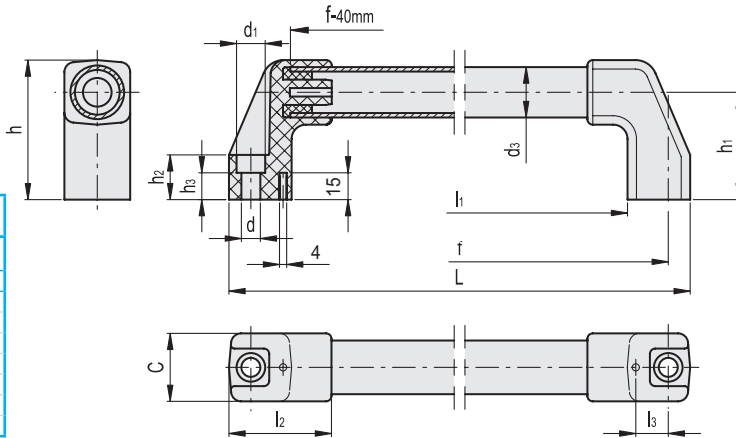

Conversion Table 1 mm = 0.039 inch			
mm	inch	mm	inch
220	8.58	424	16.69
224	8.74	520	20.47
320	12.60	524	20.63
324	12.76	620	24.41
370	14.57	624	24.57
374	14.72	720	28.35
420	16.54	724	28.50

Conversion Table 1 mm = 0.039 inch			
d		d1	
mm	inch	mm	inch
8.5	0.33	13.5	0.53
10.5	0.41	16	0.63

METRIC

M.1043

Code	Description	Code	Description	d3	f±1	L	d	d1	h	h1	h2	h3	l1	l2	l3	C	F2 [N]*	F2 [N]#	⚖
37624	M.1043/20-180-EP	37626	M.1043/20-180-AN	20	180	200	8.5	13.5	58	45	18	9.5	142	47	13	28	1500	2000	123
37621	M.1043/20-200-EP	37623	M.1043/20-200-AN	20	200	220	8.5	13.5	58	45	18	9.5	162	47	13	28	1500	2000	128
37631	M.1043/20-300-EP	37633	M.1043/20-300-AN	20	300	320	8.5	13.5	58	45	18	9.5	262	47	13	28	1500	2000	140
37641	M.1043/20-350-EP	37643	M.1043/20-350-AN	20	350	370	8.5	13.5	58	45	18	9.5	312	47	13	28	1400	1800	152
37651	M.1043/20-400-EP	37653	M.1043/20-400-AN	20	400	420	8.5	13.5	58	45	18	9.5	362	47	13	28	1200	1600	163
37661	M.1043/20-500-EP	37663	M.1043/20-500-AN	20	500	520	8.5	13.5	58	45	18	9.5	462	47	13	28	1000	1200	185
37671	M.1043/20-600-EP	37673	M.1043/20-600-AN	20	600	620	8.5	13.5	58	45	18	9.5	562	47	13	28	800	1000	210
37681	M.1043/20-700-EP	37683	M.1043/20-700-AN	20	700	720	8.5	13.5	58	45	18	9.5	662	47	13	28	600	900	232
37692	M.1043/30-180-EP	37694	M.1043/30-180-AN	30	180	204	10.5	16	78	60	25	15	134	57	18	38	3000	3900	228
37695	M.1043/30-200-EP	37697	M.1043/30-200-AN	30	200	224	10.5	16	78	60	25	15	154	57	18	38	3000	3900	233
37701	M.1043/30-300-EP	37703	M.1043/30-300-AN	30	300	324	10.5	16	78	60	25	15	254	57	18	38	3000	3900	255
37711	M.1043/30-350-EP	37713	M.1043/30-350-AN	30	350	374	10.5	16	78	60	25	15	304	57	18	38	2600	3500	277
37721	M.1043/30-400-EP	37723	M.1043/30-400-AN	30	400	424	10.5	16	78	60	25	15	354	57	18	38	2200	3300	295
37731	M.1043/30-500-EP	37733	M.1043/30-500-AN	30	500	524	10.5	16	78	60	25	15	454	57	18	38	1800	2400	337
37741	M.1043/30-600-EP	37743	M.1043/30-600-AN	30	600	624	10.5	16	78	60	25	15	554	57	18	38	1600	2000	378
37751	M.1043/30-700-EP	37753	M.1043/30-700-AN	30	700	724	10.5	16	78	60	25	15	654	57	18	38	1300	1800	417

M.1043-SST

INOX STAINLESS STEEL METRIC

Code	Description	d3	f±1	L	d	d1	h	h1	h2	h3	l1	l2	l3	C	F2 [N]*	F2 [N]#	⚖
37625	M.1043/20-180-SST	20	180	200	8.5	13.5	58	45	18	9.5	142	47	13	28	1500	2000	124
37622	M.1043/20-200-SST	20	200	220	8.5	13.5	58	45	18	9.5	162	47	13	28	1500	2000	128
37632	M.1043/20-300-SST	20	300	320	8.5	13.5	58	45	18	9.5	262	47	13	28	3000	4500	142
37642	M.1043/20-350-SST	20	350	370	8.5	13.5	58	45	18	9.5	312	47	13	28	2500	4000	154
37652	M.1043/20-400-SST	20	400	420	8.5	13.5	58	45	18	9.5	362	47	13	28	2000	3500	166
37662	M.1043/20-500-SST	20	500	520	8.5	13.5	58	45	18	9.5	462	47	13	28	1600	2500	190
37672	M.1043/20-600-SST	20	600	620	8.5	13.5	58	45	18	9.5	562	47	13	28	1100	1800	215
37682	M.1043/20-700-SST	20	700	720	8.5	13.5	58	45	18	9.5	662	47	13	28	900	1400	240
37693	M.1043/30-180-SST	30	180	204	10.5	16	78	60	25	15	134	57	18	38	3000	3900	228
37696	M.1043/30-200-SST	30	200	224	10.5	16	78	60	25	15	154	57	18	38	3000	3900	233
37702	M.1043/30-300-SST	30	300	324	10.5	16	78	60	25	15	254	57	18	38	4200	5500	258
37712	M.1043/30-350-SST	30	350	374	10.5	16	78	60	25	15	304	57	18	38	4000	5250	282
37722	M.1043/30-400-SST	30	400	424	10.5	16	78	60	25	15	354	57	18	38	3800	5000	302
37732	M.1043/30-500-SST	30	500	524	10.5	16	78	60	25	15	454	57	18	38	3500	4500	343
37742	M.1043/30-600-SST	30	600	624	10.5	16	78	60	25	15	554	57	18	38	2800	4000	385
37752	M.1043/30-700-SST	30	700	724	10.5	16	78	60	25	15	654	57	18	38	2250	3500	425

* Maximum working load # Load at breakage.

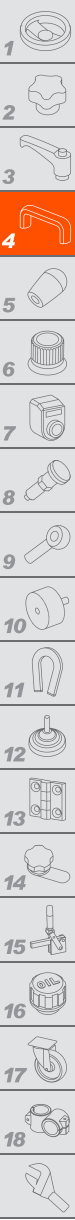

- 1
- 2
- 3
- 4
- 5
- 6
- 7
- 8
- 9
- 10
- 11
- 12
- 13
- 14
- 15
- 16
- 17
- 18

M.1043-BM-EP
M.1043-BM-AN
M.1043-BM-SST

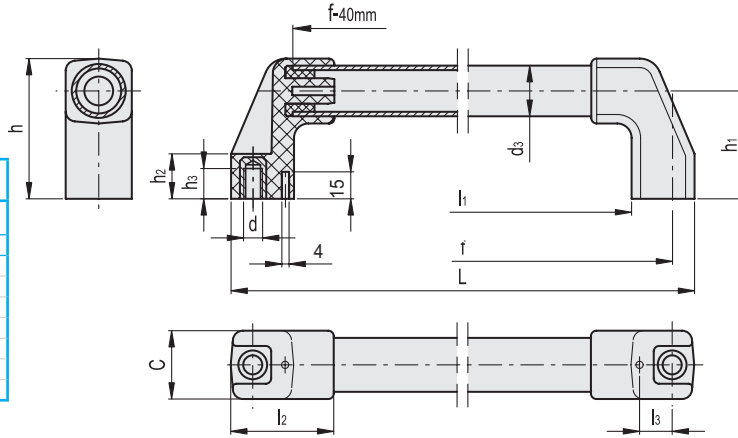

Conversion Table 1 mm = 0.039 inch			
mm	inch	mm	inch
220	8.58	424	16.69
224	8.74	520	20.47
320	12.60	524	20.63
324	12.76	620	24.41
370	14.57	624	24.57
374	14.72	720	28.35
420	16.54	724	28.50

METRIC

M.1043-BM

Code	Description	Code	Description	d3	f±1	L	d	h	h1	h2	h3	l1	l2	l3	C	F2 [N]*	F2 [N]#	⚖️
37558	M.1043 BM/20-180-EP	37578	M.1043 BM/20-180-AN	20	180	200	M8	58	45	18	9.5	142	47	13	28	1500	2000	125
37560	M.1043 BM/20-200-EP	37580	M.1043 BM/20-200-AN	20	200	220	M8	58	45	18	9.5	162	47	13	28	1500	2000	128
37561	M.1043 BM/20-300-EP	37581	M.1043 BM/20-300-AN	20	300	320	M8	58	45	18	10	262	47	13	28	1500	2000	140
37562	M.1043 BM/20-350-EP	37582	M.1043 BM/20-350-AN	20	350	370	M8	58	45	18	10	312	47	13	28	1400	1800	152
37563	M.1043 BM/20-400-EP	37583	M.1043 BM/20-400-AN	20	400	420	M8	58	45	18	10	362	47	13	28	1200	1600	163
37565	M.1043 BM/20-500-EP	37585	M.1043 BM/20-500-AN	20	500	520	M8	58	45	18	10	462	47	13	28	1000	1200	185
37567	M.1043 BM/20-600-EP	37587	M.1043 BM/20-600-AN	20	600	620	M8	58	45	18	10	562	47	13	28	800	1000	210
37569	M.1043 BM/20-700-EP	37589	M.1043 BM/20-700-AN	20	700	720	M8	58	45	18	10	662	47	13	28	600	900	232
37568	M.1043 BM/30-180-EP	37588	M.1043 BM/30-180-AN	30	180	204	M10	78	60	25	15	134	57	18	38	3000	3900	228
37570	M.1043 BM/30-200-EP	37590	M.1043 BM/30-200-AN	30	200	224	M10	78	60	25	15	154	57	18	38	3000	3900	233
37571	M.1043 BM/30-300-EP	37591	M.1043 BM/30-300-AN	30	300	324	M10	78	60	25	17	254	57	18	38	3000	3900	255
37572	M.1043 BM/30-350-EP	37592	M.1043 BM/30-350-AN	30	350	374	M10	78	60	25	17	304	57	18	38	2600	3500	277
37573	M.1043 BM/30-400-EP	37593	M.1043 BM/30-400-AN	30	400	424	M10	78	60	25	17	354	57	18	38	2200	3300	295
37575	M.1043 BM/30-500-EP	37595	M.1043 BM/30-500-AN	30	500	524	M10	78	60	25	17	454	57	18	38	1800	2400	337
37577	M.1043 BM/30-600-EP	37597	M.1043 BM/30-600-AN	30	600	624	M10	78	60	25	17	554	57	18	38	1600	2000	378
37579	M.1043 BM/30-700-EP	37599	M.1043 BM/30-700-AN	30	700	724	M10	78	60	25	17	654	57	18	38	1300	1800	417

INOX STAINLESS STEEL

METRIC

M.1043-BM-SST

Code	Description	d3	f±1	L	d	h	h1	h2	h3	l1	l2	l3	C	F2 [N]*	F2 [N]#	⚖️
37598	M.1043 BM/20-180-SST	20	180	200	M8	58	45	18	9.5	142	47	13	28	1500	2000	126
37604	M.1043 BM/20-200-SST	20	200	220	M8	58	45	18	9.5	162	47	13	28	1500	2000	128
37600	M.1043 BM/20-300-SST	20	300	320	M8	58	45	18	10	262	47	13	28	3000	4500	142
37602	M.1043 BM/20-350-SST	20	350	370	M8	58	45	18	10	312	47	13	28	2500	4000	154
37603	M.1043 BM/20-400-SST	20	400	420	M8	58	45	18	10	362	47	13	28	2000	3500	166
37605	M.1043 BM/20-500-SST	20	500	520	M8	58	45	18	10	462	47	13	28	1600	2500	190
37607	M.1043 BM/20-600-SST	20	600	620	M8	58	45	18	10	562	47	13	28	1100	1800	215
37609	M.1043 BM/20-700-SST	20	700	720	M8	58	45	18	10	662	47	13	28	900	1400	240
37608	M.1043 BM/30-180-SST	30	180	204	M10	78	60	25	15	134	57	18	38	3000	3900	228
37610	M.1043 BM/30-200-SST	30	200	224	M10	78	60	25	15	154	57	18	38	3000	3900	233
37611	M.1043 BM/30-300-SST	30	300	324	M10	78	60	25	17	254	57	18	38	4200	5500	258
37612	M.1043 BM/30-350-SST	30	350	374	M10	78	60	25	17	304	57	18	38	4000	5250	282
37613	M.1043 BM/30-400-SST	30	400	424	M10	78	60	25	17	354	57	18	38	3800	5000	302
37615	M.1043 BM/30-500-SST	30	500	524	M10	78	60	25	17	454	57	18	38	3500	4500	343
37617	M.1043 BM/30-600-SST	30	600	624	M10	78	60	25	17	554	57	18	38	2800	4000	385
37619	M.1043 BM/30-700-SST	30	700	724	M10	78	60	25	17	654	57	18	38	2250	3500	425

* Maximum working load # Load at breakage.