

Metric table

Dimensions in: millimeters - inches

l ₁	d ₁	d ₂	h ₁	h ₂	l ₂	l ₃	l ₄	l ₅	l ₆	l ₇	l ₈	l ₉	l ₁₀	m ₁	m ₂	m ₃	m ₄	m ₅	r	s	x	z
75	6.5	4	60	30	44.5	30	51	99	93.3	24	80.4	41.7	69.3	61	8	40	46	28	73	7	36	28
2.95	0.26	0.16	2.36	1.18	1.75	1.18	2.01	3.90	3.67	0.94	3.17	1.64	2.73	2.40	0.31	1.57	1.81	1.10	2.87	0.28	1.42	1.10

Specification

- Body
Aluminum **AL**
Anodized finish, natural color **EL**
- Hinge pins / washers
Stainless steel AISI 304
- Friction bearing
Plastic
- Self-lubricated
- Temperature resistant from -40 °F to +194 °F (-40 °C to +90 °C)
- Stainless Steel Characteristics → page 2143
- RoHS compliant

On request

- Other finishes / colors
- Other mounting flanges
- Other opening angles
- Other max. wall thicknesses
- Other lifting motion

Information

The GN 7243 multiple-joint hinge is installed on the inside of flaps, hatches and doors to save space and ensure protection against vandalism. The hinge has a maximum opening angle of 120°, allowing for easy accessibility and making them suitable for use with medium-thick door leaves.

Use of this hinge type leaves housing exteriors free of attachments that do not match the design or that should be avoided entirely in the interests of fast and easy cleaning.

Multiple-joint hinges are typically used in pairs. For higher loads, e.g. from large doors, these can be supplemented with additional hinges. Four reinforced washers are supplied for assembly, which can be used with mounting screws of thread size M6.

see also...

- Spacer Plates GN 7247.2 → page 1396
- Spacer Plates with Tapped Holes GN 7247.4 → page 1397
- Mounting Plates with Threaded Studs GN 7247.6 → page 1398

How to order

GN 7243-AL-75-EL

- 1** Material
- 2** Length l₁
- 3** Finish / Color

Installation position – pivot characteristics

Multiple-joint hinges can be installed on the housing with the slotted holes of the mounting flanges that are either perpendicular or parallel to the hinge axis. This results in the two pivot characteristics depicted.

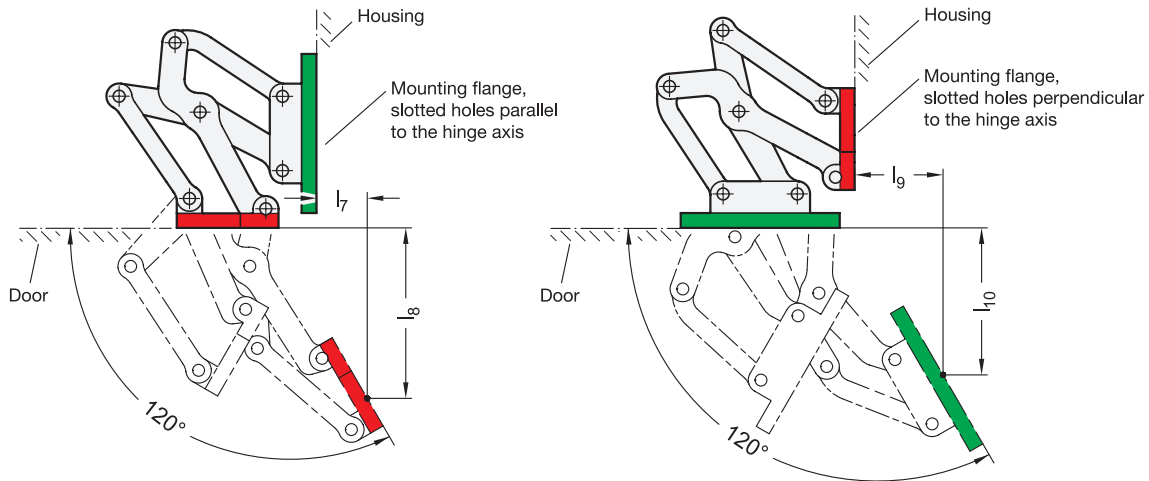

Application examples

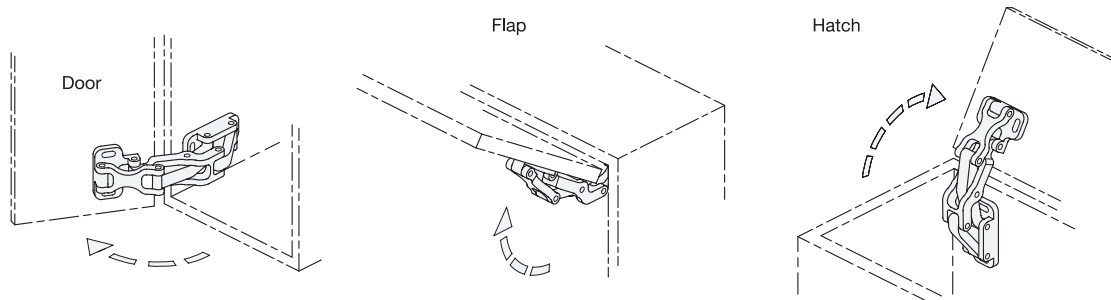

Adjustment and mounting options

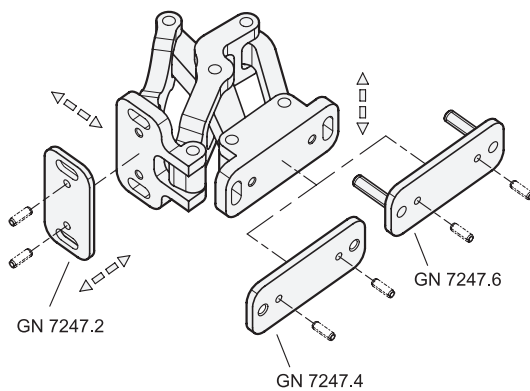

Multiple-joint hinges can be adjusted in three planes during installation. For example, this allows compensation for tolerances or establishing of required compressive forces for seals.

Two planes can be adjusted via parallel or perpendicular slotted holes in the mounting flanges. In the third plane, position corrections can be made using GN 7247.2 spacer plates.

GN 7247.4 spacer plates with tapped holes as well as GN 7247.6 mounting plates with threaded studs are also available for mounting the hinges. The latter can be welded on or inserted through the wall from the outside and fastened in place.

The holes d_2 are used to accommodate clamping or positioning pins, making it easy to position the hinge. This also prevents unintended turning or slipping under load. The pins cannot be removed for subsequent adjustment.

3.1
3.2
3.3
3.4
3.5
3.6
3.7
3.8
3.9
3.10



Design variants

Flaps, hatches and doors can be inset, surface-mounted or mitered. The maximum wall thicknesses and bend sizes for planned sheet metal constructions arise from the respective installation type.

1. Mounting flange mounted to the housing with slotted holes parallel to the hinge axis:

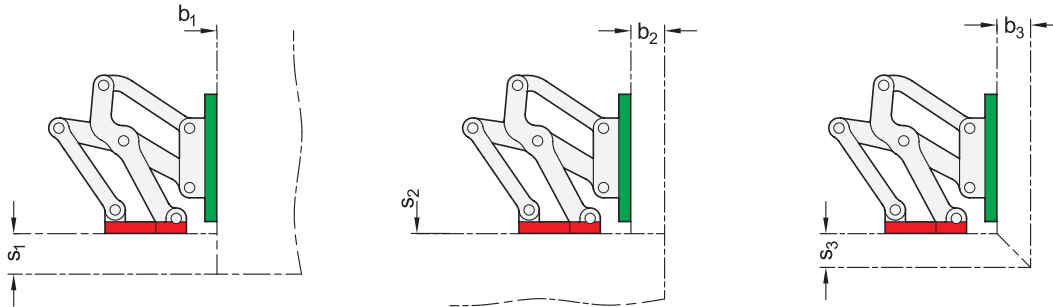

I_1	s_1 max.	b_1	s_2	b_2 max.	s_3 max.	b_3 max.
75 2.95	24 0.94	1 ... ∞	1 ... ∞	20 0.79	20 0.79	20 0.79

2. Mounting flange mounted to the housing with slotted holes perpendicular to the hinge axis:

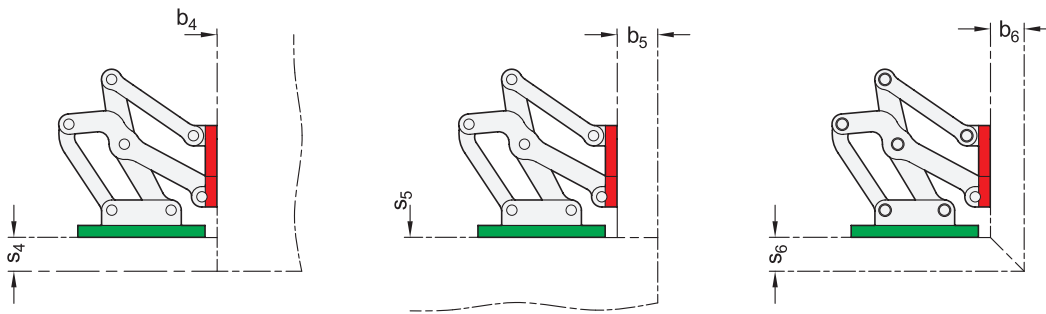

I_1	s_4 max.	b_4	s_5	b_5 max.	s_6 max.	b_6 max.
75 2.95	20 0.79	1 ... ∞	1 ... ∞	24 0.94	20 0.79	20 0.79

The design variants shown represent standard installation conditions. If the installation position of the hinge is changed or one of the two wall thickness dimensions s or b are lower, the maximum achievable dimensions change independently of each other. This makes it possible in some cases to work with larger wall thickness dimensions than those specified with the same hinge size. A simple design check via CAD or a test setup is therefore recommended.



Construction example

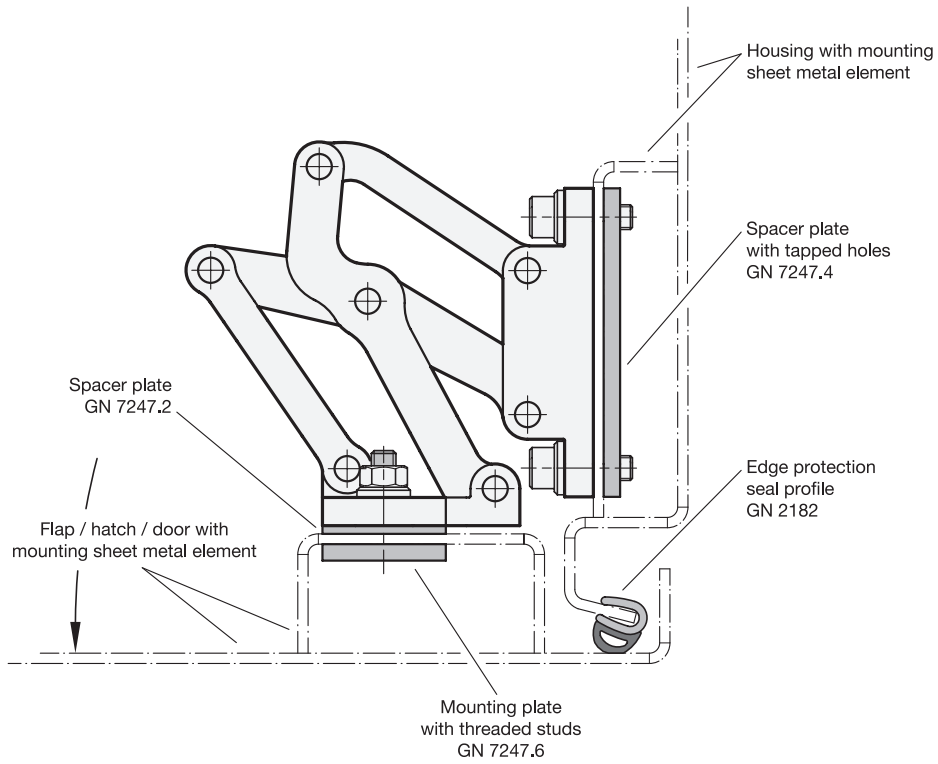

Load capacity

The maximum load of the multiple-joint hinges specified below applies to the standard use cases and serves for orientation in the case of deviating applications. The resulting forces lead to slight elastic deformation, which can be compensated for by means of the adjustment options, if necessary.

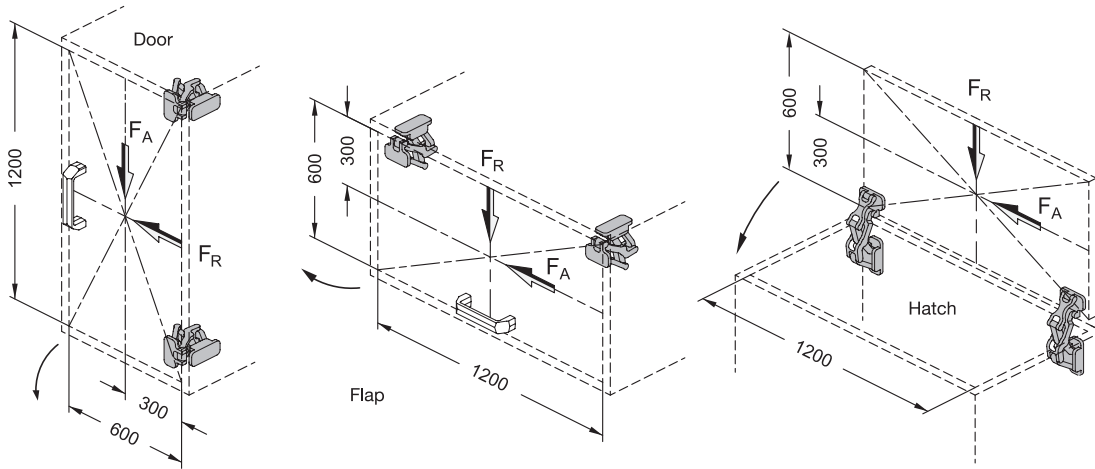

Max. load capacity per hinge pair		
I ₁	F _A (axial)	F _R (radial)
75	650 N	750 N
2.95	146.13 lbf	168.61 lbf

