

**MALE-MALE ADAPTER  
BOARD TO BOARD 9 MM**

**R223.703.080**

Series : MMBX

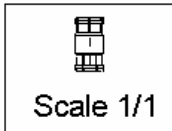
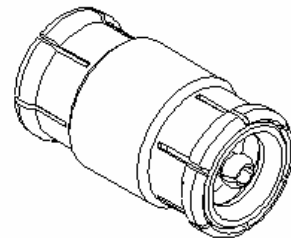
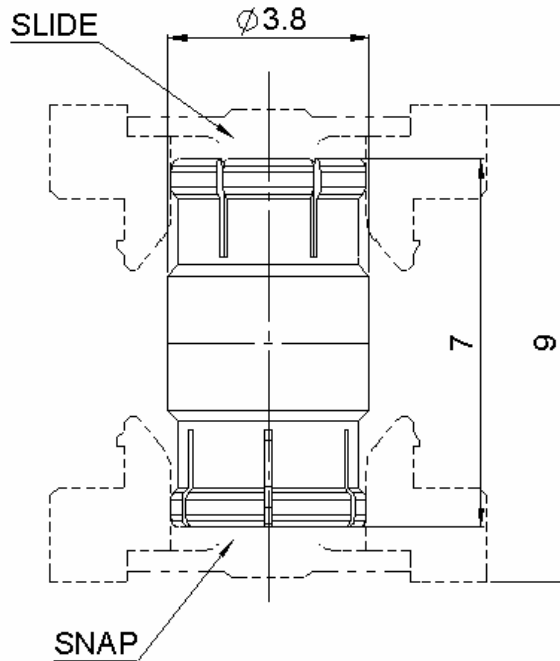

All dimensions are in mm.

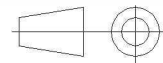

COMPONENTS	MATERIALS	PLATING (µm)
BODY	BERYLLIUM COPPER	NPGR
CENTER CONTACT	BERYLLIUM COPPER	NPGR
OUTER CONTACT		
INSULATOR	PTFE	
GASKET		
OTHERS PARTS		
-	-	-
-	-	-

Issue : 1134 B

In the effort to improve our products, we reserve the right to make changes judged to be necessary.



**MALE-MALE ADAPTER  
BOARD TO BOARD 9 MM**

**R223.703.080**

Series : MMBX

**PACKAGING**

**SPECIFICATION**

Standard	Unit	Other
<b>100</b>	<b>'W' option</b>	<b>Contact us</b>

**ELECTRICAL CHARACTERISTICS**

**ENVIRONMENTAL**

Impedance	<b>50</b>	$\Omega$
Frequency	<b>0-12.4</b>	GHz
VSWR	<b>1.083*</b> + <b>0,0000</b>	x F(GHz) Maxi
Insertion loss	<b>0.12</b>	$\sqrt{F}$ (GHz) dB Maxi
RF leakage	- ( <b>100**</b> )	- F(GHz)) dB Maxi
Voltage rating	<b>330</b>	Veff Maxi
Dielectric withstanding voltage	<b>1000</b>	Veff mini
Insulation resistance	<b>1000</b>	M $\Omega$ mini

Operating temperature	<b>-55/+155</b>	$^{\circ}$ C
Hermetic seal	<b>NA</b>	Atm.cm3/s
Panel leakage	<b>NA</b>	

**OTHER CHARACTERISTICS**

Assembly instruction **NA**

Others :

\* to 6GHz

\*\* Interface MMBX only, up to 2.5 GHz

PCB to PCB -45dB up to 2.5GHz

**MECHANICAL CHARACTERISTICS**

Center contact retention		
Axial force – Mating end	<b>10</b>	N mini
Axial force – Opposite end	<b>10</b>	N mini
Torque	<b>NA</b>	N.cm mini
Recommended torque		
Mating	<b>NA</b>	N.cm
Panel nut	<b>NA</b>	N.cm
Mating life	<b>100</b>	Cycles mini
Weight	<b>0,2430</b>	g

Issue : 1134 B

In the effort to improve our products, we reserve the right to make changes judged to be necessary.

**RADIALL** 