

FEATURES

- 5 V Output, $\pm 0.3\%$ Max
- Temperature Voltage Output, 2.1 mV/ $^{\circ}\text{C}$
- Adjustment Range, $\pm 3\%$ Min
- Excellent Temperature Stability, 8.5 ppm/ $^{\circ}\text{C}$ Max
- Low Noise, 15 μV p-p Max
- Low Supply Current, 1.4 mA Max
- Wide Input Voltage Range, 7 V to 40 V
- High Load-Driving Capability, 20 mA
- No External Components
- Short-Circuit Proof

GENERAL DESCRIPTION

The REF02 precision voltage reference provides a stable 5 V output that can be adjusted over a $\pm 6\%$ range with minimal effect on temperature stability. Single-supply operation over an input voltage range of 7 V to 40 V, low current drain of 1 mA, and excellent temperature stability are achieved with an improved band gap design. Low cost, low noise, and low power make the REF02 an excellent choice whenever a stable voltage reference is required. Applications include D/A and A/D converters, portable instrumentation, and digital voltmeters. The versatility of the REF02 is enhanced by its use as a monolithic temperature transducer. For new designs, please refer to ADR02.

PIN CONFIGURATIONS

TO-99 (J-Suffix)

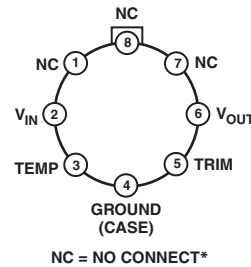

Epoxy Mini-DIP (P-Suffix)

8-Lead Hermetic DIP (Z-Suffix)

8-Lead SOIC (S-Suffix)

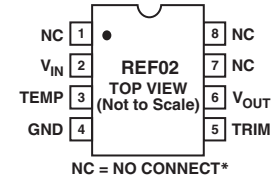

REF02RC/883 LCC (RC-Suffix)

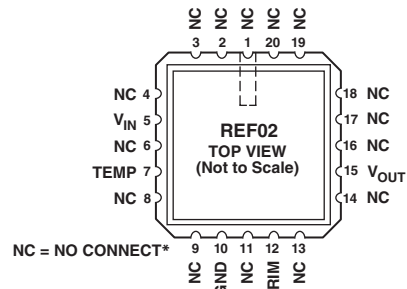

*NC = NO CONNECT. DO NOT CONNECT ANYTHING ON THESE PINS AS SOME OF THEM ARE RESERVED FOR FACTORY TESTING PURPOSES.

SIMPLIFIED SCHEMATIC

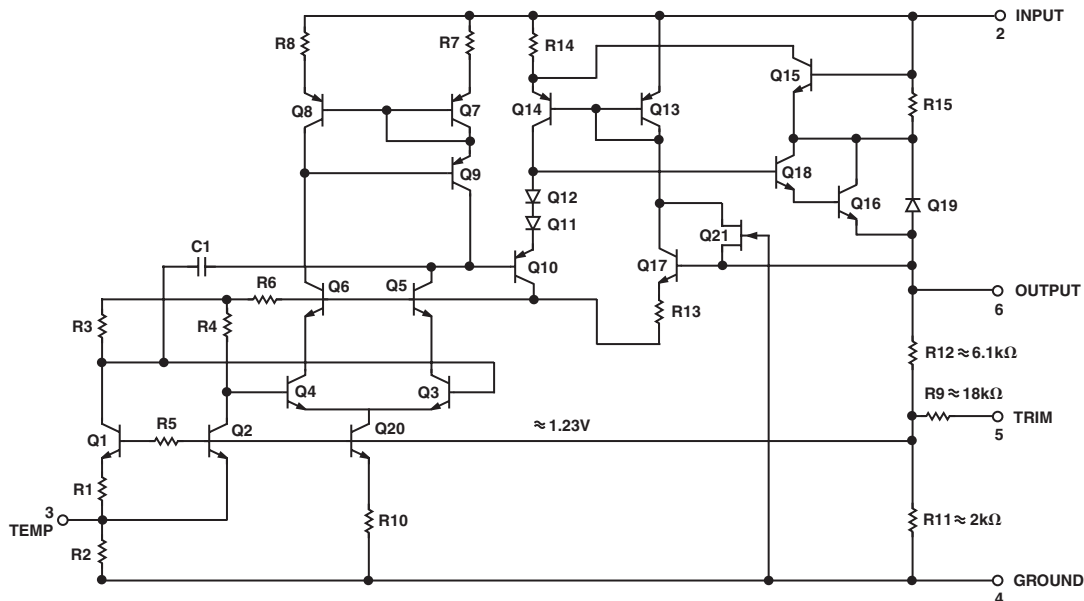

REV. C

Information furnished by Analog Devices is believed to be accurate and reliable. However, no responsibility is assumed by Analog Devices for its use, nor for any infringements of patents or other rights of third parties that may result from its use. No license is granted by implication or otherwise under any patent or patent rights of Analog Devices.

REF02—SPECIFICATIONS

ELECTRICAL SPECIFICATIONS (@ $V_{IN} = 15\text{ V}$, $T_A = 25^\circ\text{C}$, unless otherwise noted.)

Parameter	Symbol	Conditions	REF02A/E			REF02/H			Unit
			Min	Typ	Max	Min	Typ	Max	
Output Voltage	V_O	$I_L = 0\text{ mA}$	4.985	5.000	5.015	4.975	5.000	5.025	V
Output Adjustment Range	ΔV_{TRIM}	$R_P = 10\text{ k}\Omega$	± 3	± 6		± 3	± 6		%
Output Voltage Noise ¹	$e_{n\text{ p-p}}$	0.1 Hz to 10 Hz		10	15		10	15	$\mu\text{V p-p}$
Line Regulation ²		$V_{IN} = 8\text{ V to }40\text{ V}$		0.006	0.010		0.006	0.010	%/V
Load Regulation ²		$I_L = 0\text{ mA to }10\text{ mA}$		0.005	0.010		0.006	0.010	%/mA
Turn-on Settling Time ¹	t_{ON}	To $\pm 0.1\%$ of final value		5			5		μs
Quiescent Supply Current	I_{SY}	No Load		1.0	1.4		1.0	1.4	mA
Load Current	I_L		10	21		10	21		mA
Sink Current ³	I_S		-0.3	-0.5		-0.3	-0.5		mA
Short-Circuit Current	I_{SC}	$V_O = 0$		30			30		mA
Temperature Voltage Output ⁴	V_T			630			630		mV

ELECTRICAL SPECIFICATIONS (@ $V_{IN} = 15\text{ V}$, $-55^\circ\text{C} \leq T_A \leq +125^\circ\text{C}$ for REF02A and REF02, $0^\circ\text{C} \leq T_A \leq 70^\circ\text{C}$ for REF02E and REF02H, $I_L = 0\text{ mA}$, unless otherwise noted.)

Parameter	Symbol	Conditions	REF02A/E			REF02/H			Unit
			Min	Typ	Max	Min	Typ	Max	
Output Voltage Change with Temperature ^{5, 6}	ΔV_{OT}	$0^\circ\text{C} \leq T_A \leq 70^\circ\text{C}$ $-55^\circ\text{C} \leq T_A \leq +125^\circ\text{C}$		0.02	0.06		0.07	0.17	%
Output Voltage Temperature Coefficient ⁷	TCV_O			0.06	0.15		0.18	0.45	%
Change in V_O Temperature Coefficient with Output Adjustment		$R_P = 10\text{ k}\Omega$		3	8.5		10	25	ppm/ $^\circ\text{C}$
Line Regulation ($V_{IN} = 8\text{ V to }40\text{ V}$) ²		$0^\circ\text{C} \leq T_A \leq 70^\circ\text{C}$ $-55^\circ\text{C} \leq T_A \leq +125^\circ\text{C}$		0.7			0.7		ppm/%
Load Regulation ($I_L = 0\text{ mA to }8\text{ mA}$) ²		$0^\circ\text{C} \leq T_A \leq 70^\circ\text{C}$ $-55^\circ\text{C} \leq T_A \leq +125^\circ\text{C}$		0.007	0.012		0.007	0.012	%/V
Temperature Voltage Output Temperature Coefficient ⁴	TCV_T			0.009	0.015		0.009	0.015	%/V
				0.006	0.010		0.007	0.012	%/mA
				0.007	0.012		0.009	0.015	%/mA
				2.1			2.1		mV/ $^\circ\text{C}$

NOTES

¹Guaranteed by design.

²Line and Load Regulation specifications include the effect of self-heating.

³During sink current test the device meets the output voltage specified.

⁴Limit current in or out of Pin 3 to 50 nA and capacitance on Pin 3 to 30 pF.

⁵ ΔV_{OT} is defined as the absolute difference between the maximum output voltage and the minimum output voltage over the specified temperature range expressed as a percentage of 5 V:

$$\Delta V_{OT} = \left| \frac{V_{MAX} - V_{MIN}}{5\text{ V}} \right| \times 100$$

⁶ ΔV_{OT} specification applies trimmed to 5,000 V or untrimmed.

⁷ TCV_O is defined as ΔV_{OT} divided by the temperature range, i.e.,

$$TCV_O = \frac{\Delta V_{OT}}{70^\circ\text{C}}$$

Specifications are subject to change without notice.

ELECTRICAL SPECIFICATIONS (@ $V_{IN} = 15\text{ V}$, $T_A = 25^\circ\text{C}$, unless otherwise noted.)

Parameter	Symbol	Conditions	REF02C			REF02D			Unit
			Min	Typ	Max	Min	Typ	Max	
Output Voltage	V_O	$I_L = 0\text{ mA}$	4.950	5.000	5.050	4.900	5.000	5.100	V
Output Adjustment Range	ΔV_{TRIM}	$R_P = 10\text{ k}\Omega$	± 2.7	± 6.0		± 2.0	± 6.0		%
Output Voltage Noise ¹	$e_{n\text{ p-p}}$	0.1 Hz to 10 Hz		12	18		12		$\mu\text{V p-p}$
Line Regulation ²		$V_{IN} = 8\text{ V to } 40\text{ V}$		0.009	0.015		0.010	0.04	%/V
Load Regulation ²		$I_L = 0\text{ mA to } 8\text{ mA}$		0.006	0.015				%/mA
		$I_L = 0\text{ mA to } 4\text{ mA}$					0.015	0.04	%/mA
Turn-On Settling Time ¹	t_{ON}	To $\pm 0.1\%$ of final value		5			5		μs
Quiescent Supply Current	I_{SY}	No Load		1.0	1.6		1.0	2.0	mA
Load Current	I_L		8	21		8	21		mA
Sink Current ³	I_S		-0.3	-0.5		-0.3	-0.5		mA
Short-Circuit Current	I_{SC}	$V_O = 0$		30			30		mA
Temperature Voltage Output ⁴	V_T			630			630		mV

ELECTRICAL SPECIFICATIONS (@ $V_{IN} = 15\text{ V}$, $I_L = 0\text{ mA}$, $0^\circ\text{C} \leq T_A \leq 70^\circ\text{C}$ for REF02CJ, CZ, DP, and $-40^\circ\text{C} \leq T_A \leq +85^\circ\text{C}$ for REF02CP and CS, unless otherwise noted.)

Parameter	Symbol	Conditions	REF02C			REF02D			Unit
			Min	Typ	Max	Min	Typ	Max	
Output Voltage Change with Temperature ^{5,6}	ΔV_{OT}			0.14	0.45		0.49	1.7	%
Output Voltage ⁷ Temperature Coefficient	TCV_O			20	65		70	250	ppm/°C
Change in V_O Temperature Coefficient with Output Adjustment		$R_P = 10\text{ k}\Omega$		0.7			0.7		ppm/%
Line Regulation ²		$V_{IN} = 8\text{ V to } 40\text{ V}$		0.011	0.018		0.012	0.05	%/V
Load Regulation ²		$I_L = 0\text{ mA to } 5\text{ mA}$		0.008	0.018		0.016	0.05	%/mA
Temperature Voltage Output Temperature Coefficient ⁴	TCV_T			2.1			2.1		mV/°C

NOTES

¹Guaranteed by design.

²Line and Load Regulation specifications include the effect of self-heating.

³During sink current test the device meets the output voltage specified.

⁴Limit current in or out of Pin 3 to 50 nA and capacitance on Pin 3 to 30 pF.

⁵ ΔV_{OT} is defined as the absolute difference between the maximum output voltage and the minimum output voltage over the specified temperature range expressed as a percentage of 10 V:

$$\Delta V_{OT} = \left| \frac{V_{MAX} - V_{MIN}}{5\text{ V}} \right| \times 100$$

⁶ ΔV_{OT} specification applies trimmed to 5 V or untrimmed.

⁷ TCV_O is defined as ΔV_{OT} divided by the temperature range, i.e.,

$$TCV_O = \frac{\Delta V_{OT}}{70^\circ\text{C}}$$

Specifications are subject to change without notice.

REF02

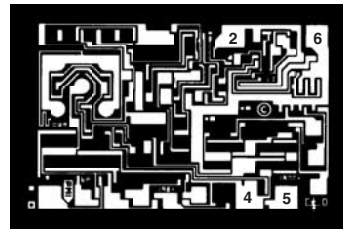

2. INPUT VOLTAGE (V_{IN})
4. GROUND
5. TRIM
6. OUTPUT VOLTAGE (V_{OUT})

DIE SIZE 0.074 × 0.048 INCH, 3552 SQUARE MILS
(1.88 × 1.22 MM, 2.29 SQUARE MM)

Figure 1. Die Characteristics (125°C Tested Dice Available)

WAFER TEST LIMITS* (@ $V_{IN} = 15\text{ V}$, $T_A = 25^\circ\text{C}$ for REF02N and REF02G devices, $T_A = 125^\circ\text{C}$ for REF02NT and REF02GT devices, unless otherwise noted.)

Parameter	Symbol	Conditions	REF02NT Limit	REF02N Limit	REF02GT Limit	REF02G Limit	Unit
Output Voltage	V_O	$I_L = 0$	4.975 5.025	4.985 5.015	4.950 5.050	4.975 5.025	V min V max
Output Adjustment Range	V_{TRIM}	$R_P = 10\text{ k}\Omega$		± 3.0		± 3.0	% min
Line Regulation		$V_{IN} = 8\text{ V to }40\text{ V}$	0.015	0.01	0.015	0.01	%/V max

*Electrical tests are performed at wafer probe to the limits shown. Due to variations in assembly methods and normal yield loss, yield after packaging is not guaranteed for standard product dice. Consult factory to negotiate specifications based on dice lot qualification through sample lot assembly and testing.

TYPICAL ELECTRICAL CHARACTERISTICS (@ $V_{IN} = 15\text{ V}$, $T_A = 25^\circ\text{C}$, unless otherwise noted.)¹

Parameter	Symbol	Conditions	REF02NT Typical	REF02N Typical	REF02GT Typical	REF02G Typical	Unit
Temp. Voltage Output ^{2,3}	V_T		630	630	630	630	mV
Temp. Voltage Output Temperature Coefficient ^{2,3}	TCV_T		2.1	2.1	2.1	2.1	mV/°C
Output Voltage Temperature Coefficient	TCV_O		10	10	10	10	ppm/°C
Load Regulation		$I_L = 0\text{ mA to }10\text{ mA}$ $I_L = 0\text{ mA to }8\text{ mA}$, NT, GT @ 125°C	0.007	0.005	0.009	0.006	%/mA
Output Voltage Noise	$e_{n\text{ p-p}}$	0.1 Hz to 10 Hz	10	10	10	10	$\mu\text{V p-p}$
Turn-On Settling Time	t_{ON}	To $\pm 0.1\%$ of Final Value NT, GT GT @ 125°C	7.5	5.0	7.5	5.0	μs
Quiescent Current	I_{SY}	No Load, NT, GT @ 125°C	1.4	1.0	1.4	1.0	mA
Load Current	I_L		21	21	21	21	mA
Sink Current	I_S		-0.5	-0.5	-0.5	-0.5	mA
Short-Circuit Current	I_{SC}	$V_O = 0$	30	30	30	30	mA

NOTES

¹For 25°C specifications of REF02NT and REF02GT, see REF02N and REF02G respectively.

²See AN18 for detailed REF02 thermometer applications information.

³Limit circuit in or out of Pin 3 to 50 nA and capacitance on Pin 3 to 30 pF.

ABSOLUTE MAXIMUM RATINGS*

Input Voltage	40 V
Output Short-Circuit Duration (to Ground or V_{IN})	Indefinite
Storage Temperature Range	
J, RC, and Z Packages	-65°C to +150°C
P Package	-65°C to +125°C
Operating Temperature Range	
REF02A, REF02, REF02RC	-55°C to +125°C
REF02CJ, REF02CZ	0°C to 70°C
REF02CP, REF02CS, REF02E, REF02H	-40°C to +85°C
Lead Temperature (Soldering, 60 sec)	300°C

*Absolute maximum ratings apply to both DICE packaged parts, unless otherwise noted.

Package Type	θ_{JA} *	θ_{JC}	Unit
TO-99 (J)	170	24	°C/W
8-Lead Hermetic DIP (Z)	162	26	°C/W
8-Lead Plastic DIP (P)	110	50	°C/W
20-Contact LCC (RC, TC)	120	40	°C/W
8-Lead SOIC (S)	160	44	°C/W
20-Contact PLCC (PC)	80	39	°C/W

* θ_{JA} is specified for worst-case mounting conditions, i.e., θ_{JA} is specified for device in socket for TO, CERDIP, P-DIP, and LCC packages; θ_{JA} is specified for device soldered to printed circuit board for SO and PLCC packages.

ORDERING GUIDE¹

$T_A = 25^\circ\text{C}$ $\Delta V_{OS\text{ Max}}$ (mV)	Package Description				Operating Temperature Range
	TO-99	Cerdip 8-Lead	Plastic 8-Lead	LCC 20-Contact	
±15		REF02AZ ²			MIL
±15	REF02EJ	REF02EZ			XIND
±25	REF02J ²	REF02Z ²		REF02RC/883	MIL
±25	REF02HJ	REF02HZ	REF02HP		XIND
±50	REF02CJ	REF02CZ			COM
±50			REF02CP		XIND
±50			REF02CS ³		XIND
±100			REF02DP		COM

NOTES

¹Burn-in is available on commercial and industrial temperature range parts in Cerdip, plastic DIP, and TO-can packages.

²For devices processed in total compliance to MIL-STD-883, add 883 after part number. Consult factory for 883 data sheet.

³For availability and burn-in information on SOIC and PLCC packages, contact your local sales office.

CAUTION

ESD (electrostatic discharge) sensitive device. Electrostatic charges as high as 4000 V readily accumulate on the human body and test equipment and can discharge without detection. Although the REF02 features proprietary ESD protection circuitry, permanent damage may occur on devices subjected to high energy electrostatic discharges. Therefore, proper ESD precautions are recommended to avoid performance degradation or loss of functionality.



REF02 – Typical Performance Characteristics

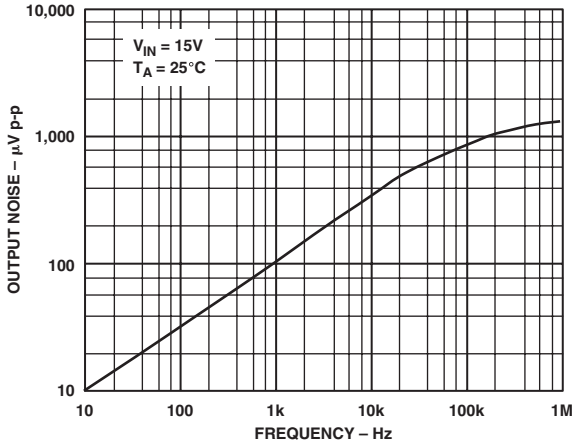

TPC 1. Output Wideband Noise vs. Bandwidth (0.1 Hz to Frequency Indicated)

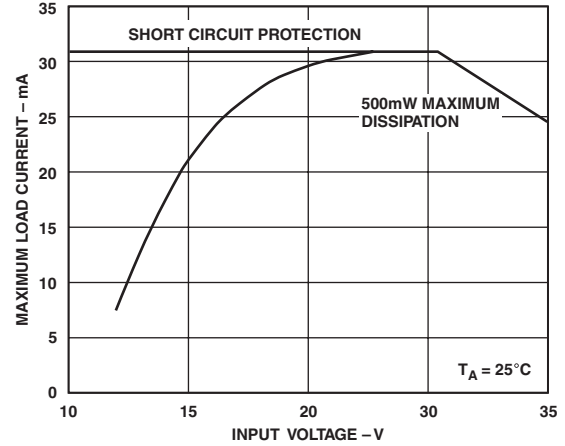

TPC 4. Maximum Load Current vs. Input Voltage

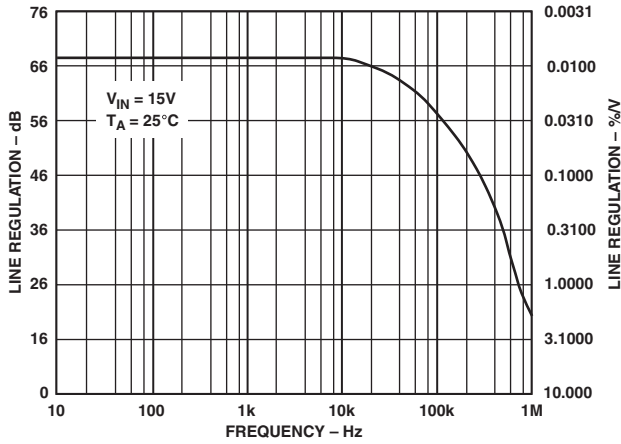

TPC 2. Line Regulation vs. Frequency

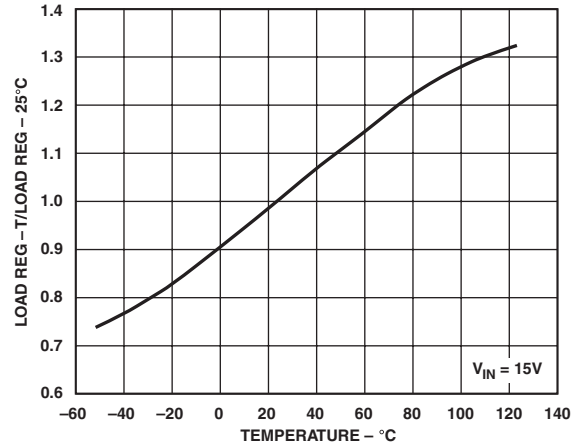

TPC 5. Normalized Load Regulation ($\Delta I_L = 10\text{ mA}$) vs. Temperature

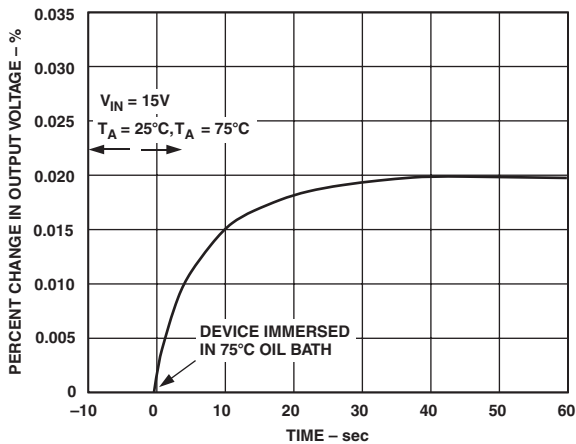

TPC 3. Output Change Due to Thermal Shock

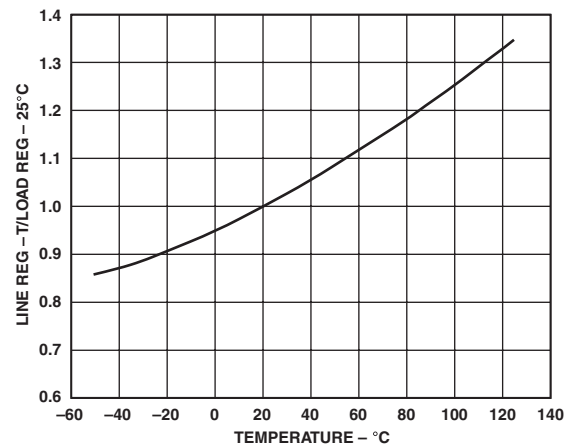

TPC 6. Normalized Line Regulation vs. Temperature

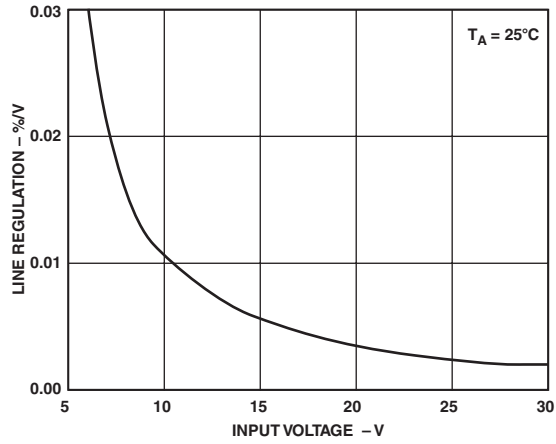

TPC 7. Line Regulation vs. Input Voltage

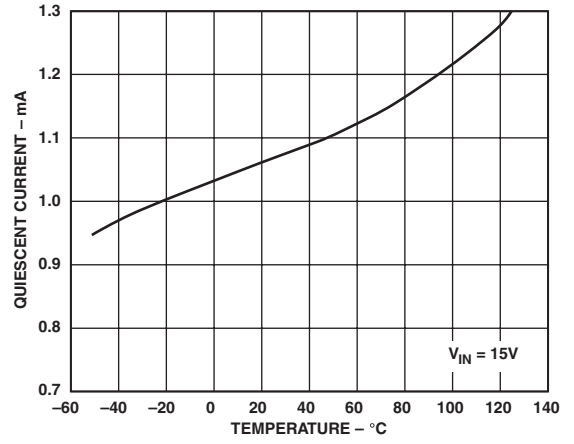

TPC 9. Quiescent Current vs. Temperature

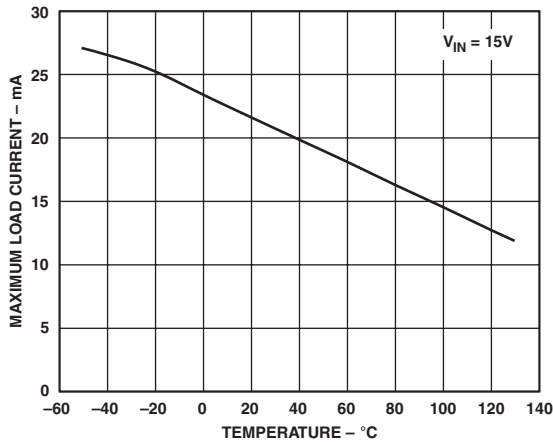

TPC 8. Maximum Load Current vs. Temperature

REF02

OUTPUT ADJUSTMENT

The REF02 trim terminal can be used to adjust the output voltage over a $5\text{ V} \pm 300\text{ mV}$ range. This feature allows the system designer to trim system errors by setting the reference to a voltage other than 5 V. Of course, the output can also be set to exactly 5.000 V, or to 5.12 V for binary applications.

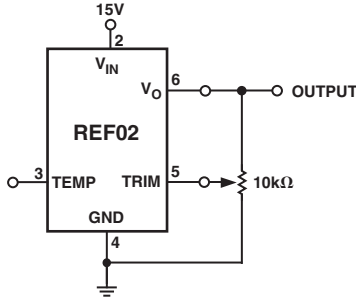

Figure 2. Output Adjustment Circuit

Adjustment of the output does not significantly affect the temperature performance of the device. The temperature coefficient change is approximately 0.7 ppm/°C for 100 mV of output adjustment.

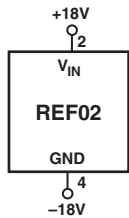

Figure 3. Burn-In Circuit

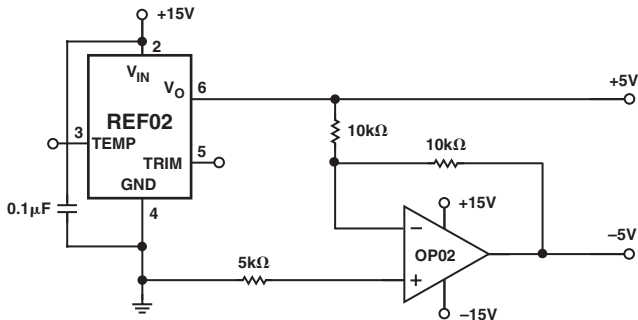

Figure 4. ±5 V Reference

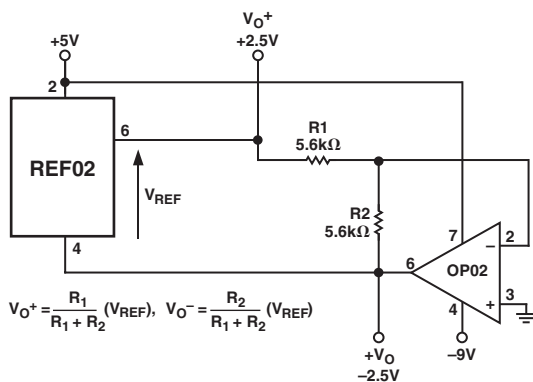

Figure 5. ±2.5 V Reference

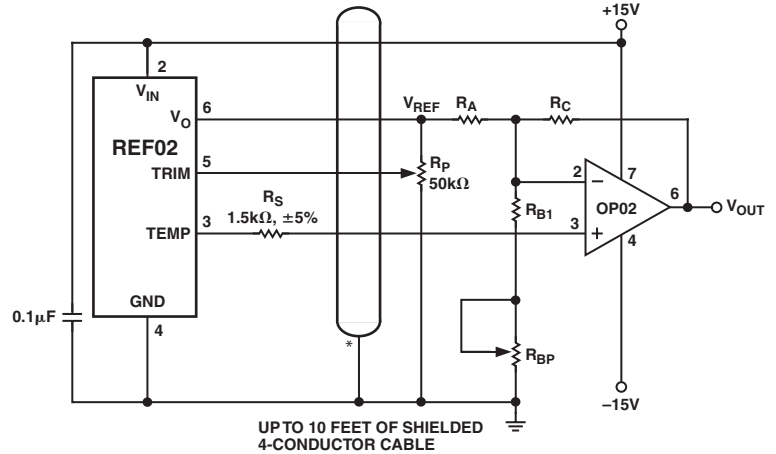

Figure 6. Precision Temperature Transducer with Remote Sensor

Table I. Resistor Values

TCV _{OUT} SLOPE(S)	10 mV/°C	100 mV/°C	10 mV/°F
Temperature Range	-55°C to +125°C	-55°C to +125°C	-67°F to +2.57°C
Output Voltage Range	-0.55 V to +1.25 V	-5.5 V to +12.5 V*	-0.67 V to +2.57 V
Zero Scale	0 V @ 0°C	0 V @ 0°C	0 V @ 0°F
R _A (±1% resistor)	9.09 kΩ	15 kΩ	7.5 kΩ
R _{B1} (±1% resistor)	1.5 kΩ	1.82 kΩ	1.21 kΩ
R _{BP} (Potentiometer)	200 Ω	500 Ω	200 Ω
R _C (±1% resistor)	5.11 kΩ	84.5 kΩ	8.25 kΩ

*For 125°C operation, the op amp output must be able to swing to 12.5 V, increase V_{IN} to 18 V from 15 V if this is a problem.

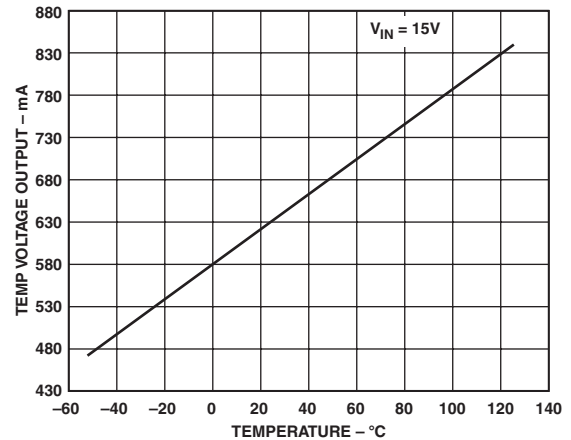

Figure 7. Typical Temperature Voltage Output vs. Temperature (REF02A)

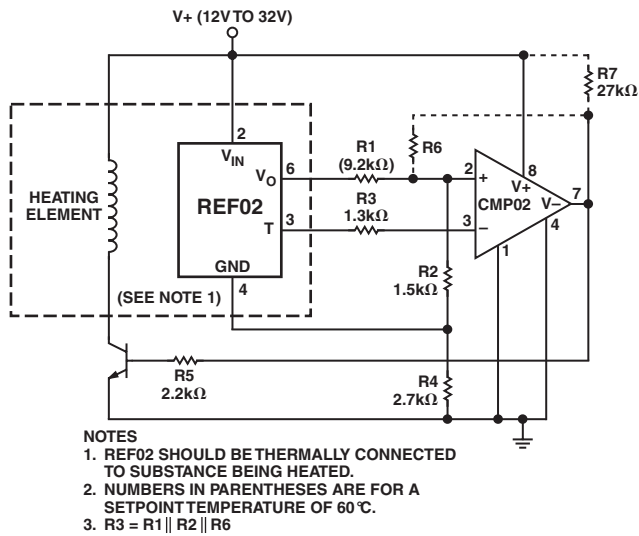

Figure 8. Temperature Controller

REFERENCE STACK WITH EXCELLENT LINE REGULATION

Two REF01s and one REF02 can be stacked to yield 5.000 V, 15.000 V, and 25.000 V outputs. An additional advantage is near-perfect line regulation of the 5.0 V and 15.0 V output. A 27 V to 55 V input change produces an output change that is less than the noise voltage of the devices. A load bypass resistor (RB) provides a path for the supply current (ISY) of the 15.000 V regulator.

In general, any number of REF01s and REF02s can be stacked this way. For example, 10 devices will yield 10 outputs in 5 V or 10 V steps. The line voltage can change from 100 V to 130 V. However, care must be taken to ensure that the total load currents do not exceed the maximum usable current (typically 21 mA).

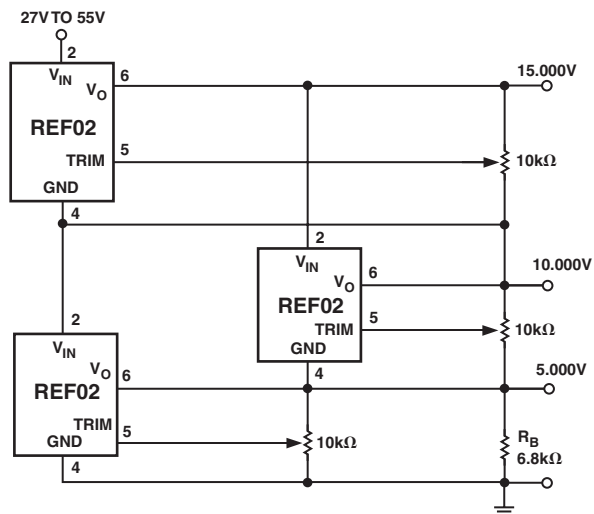

Figure 9. Reference Stack

PRECISION CURRENT SOURCE

A current source with 35 V output compliance and excellent output impedance can be obtained using this circuit. REF02 keeps the line voltage and power dissipation constant in device; the only important error consideration at room temperature is the negative supply rejection of the op amp. The typical $3 \mu\text{V/V} \times 35 \text{ V/5 V}$ in output current over a 25 V range. For example, a 5 mA current source can be built ($R = 1 \text{ k}\Omega$) with $350 \text{ M}\Omega$ output impedance.

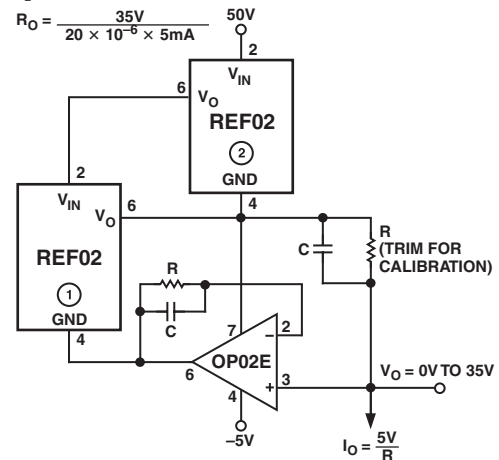

Figure 10. Precision Current Source

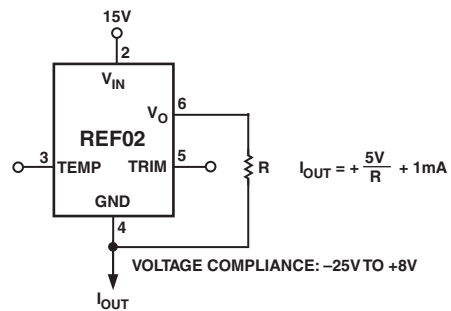

Figure 11. Current Source

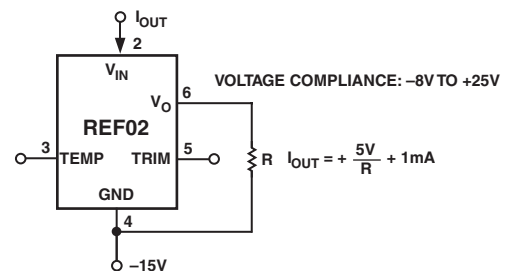

Figure 12. Current Sink

REF02

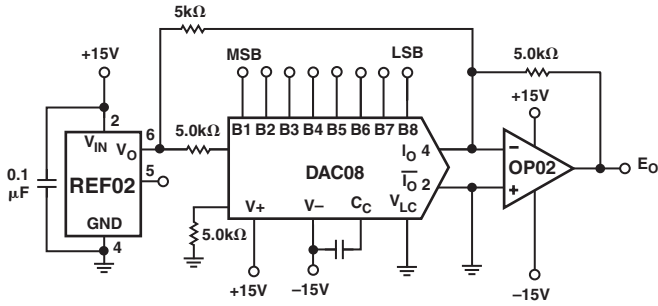

Figure 13. D/A Converter Reference

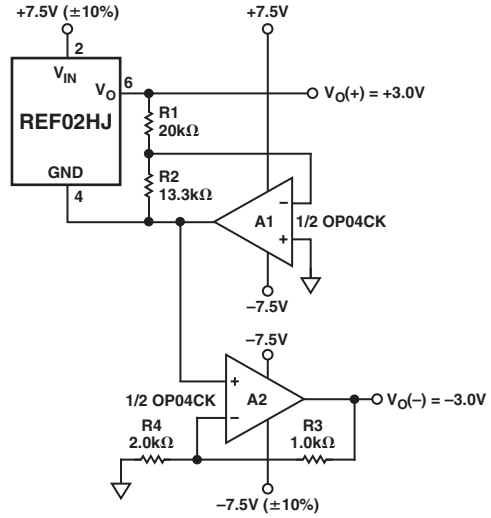

Figure 14. ± 3 V Reference

SUPPLY BYPASSING

For best results, it is recommended that the power supply pin be bypassed with a 0.1 μ F capacitor.

OUTLINE DIMENSIONS

8-Lead Ceramic DIP-Glass Hermetic Seal [CERDIP]
(Q-8)

Dimensions shown in inches and (millimeters)

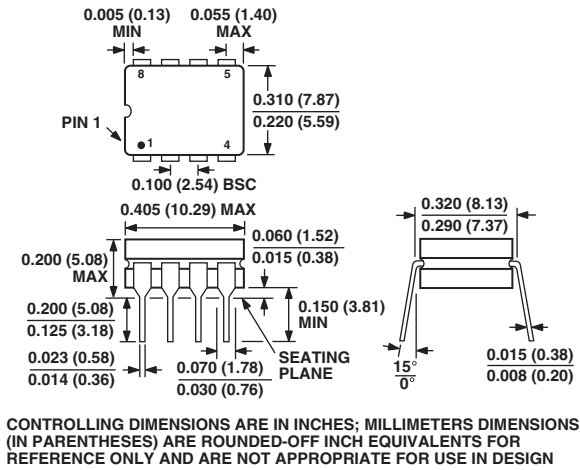

8-Lead Plastic Dual-in-Line Package [PDIP]
(N-8)

Dimensions shown in inches and (millimeters)

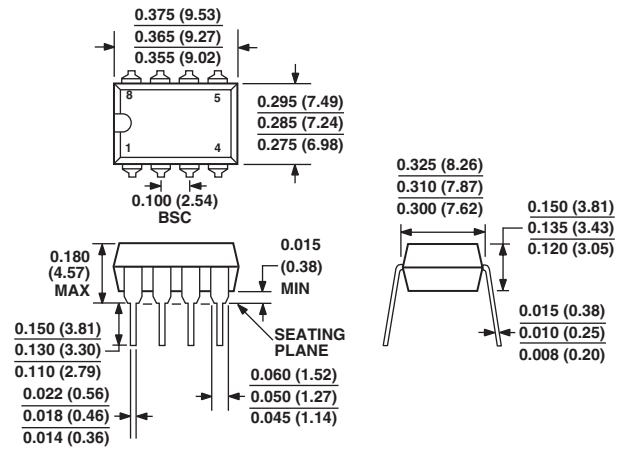

8-Lead Metal Can [TO-99]
(H-08)

Dimensions shown in inches and (millimeters)

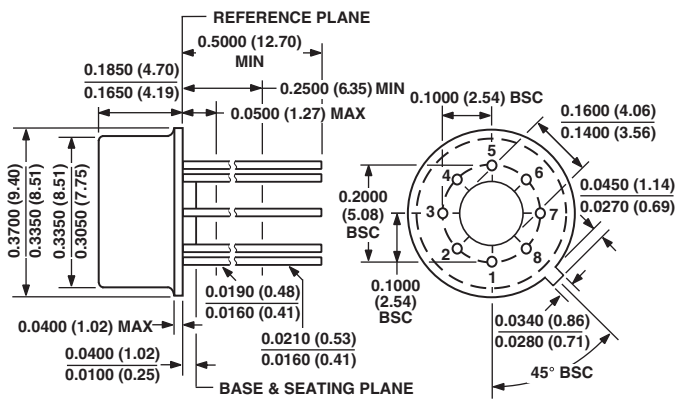

20-Terminal Ceramic Leaded Chip Carrier [LCC]
(E-20A)

Dimensions shown in millimeters and (inches)

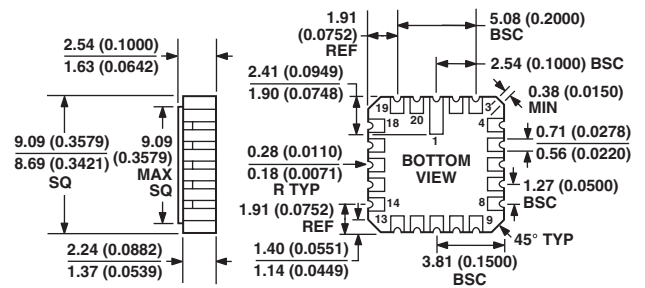

REF02

Revision History

Location	Page
10/02—Data Sheet changed from REV. B to REV. C.	
Changes to FEATURES	1
Changes GENERAL DESCRIPTION	1
Changes SIMPLIFIED SCHEMATIC	1
Changes SPECIFICATIONS	2
Changes ABSOLUTE MAXIMUM RATINGS	5
Changes Package Type	5
Changes ORDERING GUIDE	5
Updated OUTLINE DIMENSIONS	11

C00375-0-10/02(C)

PRINTED IN U.S.A.