

Click to
ORDER
samples

AM40EW-NZ



Encapsulated

This new series AM40EW-NZ provides a wide input voltage range of 40-160VDC required by input voltages of 72V, 96V, 110V in railway industry. Outputs and isolation voltage up to 3000VDC/1500VAC ensure them to meet the railway locomotive EN50155 standard requirements and EN62368 standard requirements. The converters also offer a wide operating temperature range of -40°C to +85°C. Protections for input UVP, OSC, OCP, OVP and OTP are also included. Housed in 2x1 inch package, this AM40EW-NZ series is available for packages with optional heat sink in PCB mount, chassis mount and DIN rail mount, which offers flexibility to the designer of the end-product and makes this series ideal for applications in railway monitoring, lighting equipment, information display and other railway vehicle-related equipment.

Features



- Ultra-wide Input: 40 - 160VDC
- Operating Temp: -40 °C to +85 °C
- High isolation voltage: 3000VDC/1500VAC
- Low ripple & noise, 150mV(p-p), typ.
- Output short circuit, over-current, over-voltage, over temperature protection
- Regulated Output

Summary

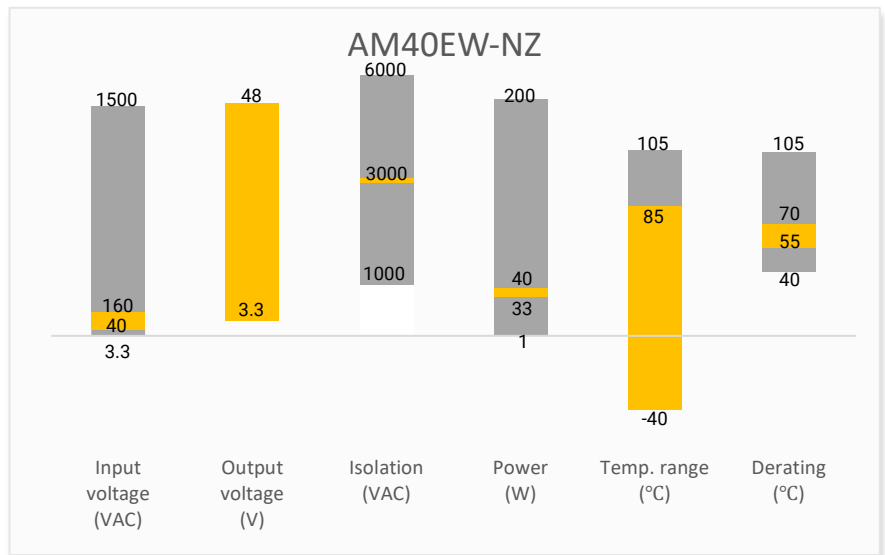

Training

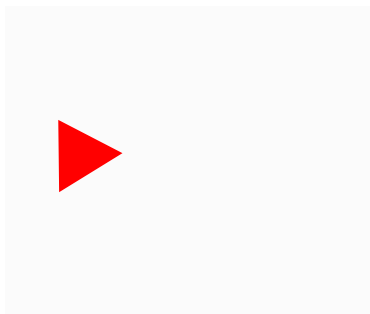

Product Training Video
(click to open)

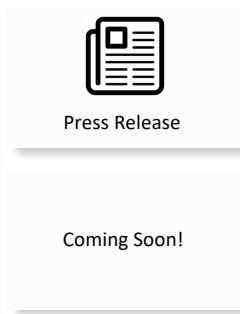

Application Notes

Applications



Power Grid



Industrial



Telecom



Instrumentation

Models & Specifications

Single Output							
Model	Input Voltage (VDC)	Output Voltage (VDC)	Input Current max (mA)	Output Current max (A)	Isolation (VDC/VAC)	Maximum capacitive Load (μF)	Efficiency Typ. (%)
AM40EW-11003SH30-NZ	110 (40 - 160)	3.3	353	10	3000/1500	10000	85
AM40EW-11005SH30-NZ	110 (40 - 160)	5	423	8	3000/1500	10000	86
AM40EW-11012SH30-NZ	110 (40 - 160)	12	423	3.33	3000/1500	2700	89
AM40EW-11015SH30-NZ	110 (40 - 160)	15	423	2.67	3000/1500	1680	89
AM40EW-11024SH30-NZ	110 (40 - 160)	24	423	1.67	3000/1500	680	87
AM40EW-11048SH30-NZ	110 (40 - 160)	48	423	0.83	3000/1500	470	87

Note: Use suffix "-K" for optional heat sink. Use suffix "ST" for chassis and suffix "STD" for DIN-Rail mounting (ex. AM40EW-11005SH30-NZ-K-STD is with the heatsink attached version. AM40EW-11005SH30-NZ-K-STD is DIN-Rail mounting version with the heatsink. AM40EW-11005SH30-NZ-ST is chassis mounting and AM40EW-11005SH30-NZ-STD is DIN-Rail mounting version.)

Input Specification				
Parameters	Conditions	Typical	Maximum	Units
Voltage range	Nominal 110	40 – 160		VDC
Input under voltage lockout	ON/OFF	40/32		VDC
Startup voltage		40		VDC
Startup time	Nominal input and resistive load	20		ms
Filter	Pi network			
Absolute maximum rating	Duration 1s max.		180	VDC
Input reflected ripple current		25		mA pk-pk
On/Off Control	ON – 3.5 to 12Vdc or open; OFF – 0 to 1.2Vdc or Short circuit Pin 1 and Pin 2, idle current 2mA typ. 10mA max.			

Isolation Specification				
Parameters	Conditions	Typical	Maximum	Units
Tested I/O voltage	60 sec, leakage of 1mA max.	3000		VDC
	60 sec, leakage of 5mA max	1500		VAC
Resistance	500Vdc	>1000		MOhm
Capacitance	100KHz/0.1V	2200	3000	pF

Output Specification					
Parameters	Conditions	Typical	Maximum	Units	
Voltage accuracy	0-100% load	±1.0	±3.0	%	
Line regulation	Full load, main input range	±0.4	±1.0	%	
Load regulation	0-100% load	±0.5	±1.0	%	
Voltage adjustment			±10	%Vout	
Short circuit protection	Continuous, Auto recovery				
Over current protection		110~190		% of Iout	
Over voltage protection		110~160		% of Vout	
Temperature coefficient		±0.02	±0.03	%/°C	
Ripple & Noise*		150	200	mV pk-pk	
Transient recovery time	25% load step change	300	500	µS	
Transient response deviation	25% load step change	3.3V/5V models	±5	±8	%
		Others	±3	±5	

* 20MHz bandwidth. The Ripple & Noise may reach 5% of Vout max. when the adding load below 5% of total load.

General Specifications				
Parameters	Conditions	Typical	Maximum	Units
Switching frequency	Full load	220		KHz
Operating temperature	See derating graph	-40 to +85		°C
Storage temperature		-55 to +125		°C
Over temperature protection	At case	100	130	°C
Lead temperature	1.5mm from case 10 sec.		300	°C
Cooling	Free air convection			
Humidity	Non-condensing		95	% RH
Case material	Aluminum			
Weight	PCB mountable models		26	g
	With optional -K heatsink models		34	
	With optional -ST mounting plate		48	
	With optional -STD mounting plate		68	
	With optional -K-ST mounting plate and heatsink		56	
Dimensions (L x W x H)	PCB mountable models		2 x 1 x 0.47 inches (50.8 x 25.4 x 11.8 mm)	
	With optional -K heatsink models		2.02 x 1.03 x 0.65 inches (51.4 x 26.2 x 16.5 mm)	
	With optional -ST mounting plate		2.99 x 1,24 x 0.83 inches (76 x 31.5 x 21.2 mm)	
	With optional -STD mounting plate		2.99 x 1,24 x 1.02 inches (76 x 31.5 x 25.8 mm)	
	With optional -K-ST mounting plate and heatsink		2.99 x 1,24 x 1.00 inches (76 x 31.5 x 25.3 mm)	
With optional -K-STD mounting plate and heatsink		2.99 x 1,24 x 1.18 inches (76 x 31.5 x 29.9 mm)		
MTBF	> 500 000 hrs (MIL-HDBK -217F, t=+25°C)/Full Load			

All specifications in this datasheet are measured at an ambient temperature of 25°C, humidity<75%, nominal input voltage and at rated output load unless otherwise specified.

Safety Specifications			
Parameters			
Standards	Information technology Equipment	Design to meet IEC/EN/UL62368-1	
	Electronic equipment in railway applications	Design to meet EN50155	
	EMI - Conducted and Radiated Emission	CE	CISPR32/EN55032, Class B with the recommended EMC circuit EN50121-3-2 with the recommended EMC circuit 99dBuV from 0.15-0.5MHZ 93dBuV from 0.5-30MHZ
		RE	CISPR32/EN55032, Class B with the recommended EMC circuit EN50121-3-2, with the recommended EMC circuit 40dBuV from 30-230MHZ at 10m 47dBuV from 0.23-1GHZ at 10m
	Electrostatic Discharge Immunity	IEC/EN61000-4-2, Contact $\pm 6KV$ / Air $\pm 8KV$, Criteria A EN50121-3-2, Contact $\pm 6KV$ / Air $\pm 8KV$, Criteria A	
	RF, Electromagnetic Field Immunity	IEC/EN61000-4-3, 20V/m, Criteria A EN50121-3-2, 20V/m, Criteria A	
	Electrical Fast Transient/Burst Immunity**	IEC/EN61000-4-4, $\pm 4KV$ with recommended EMC circuit, Criteria A EN50121-3-2, $\pm 2KV$ with recommended EMC circuit, Criteria A	
	Surge Immunity**	IEC/EN61000-4-5, $\pm 2KV$ with recommended EMC circuit, Criteria A EN50121-3-2, L-L $\pm 1KV$ with recommended EMC circuit, Criteria A	
RF, Conducted Disturbance Immunity	IEC/EN61000-4-6, 10Vr.m.s, Criteria A EN50121-3-2, 10Vr.m.s @0.15~80MHz, Criteria A		

Derating

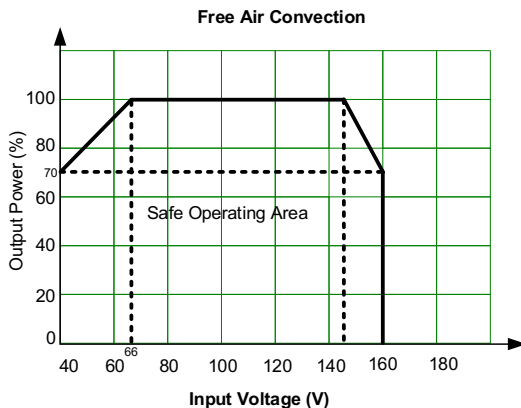
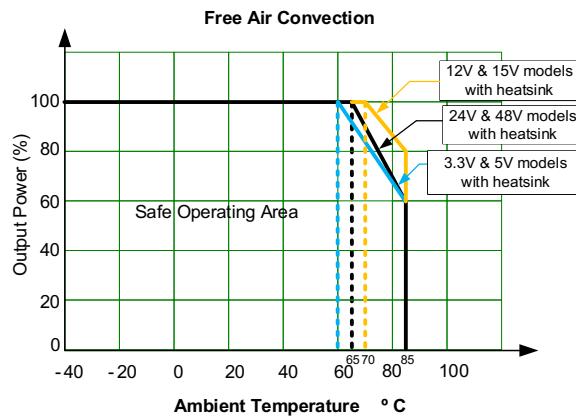
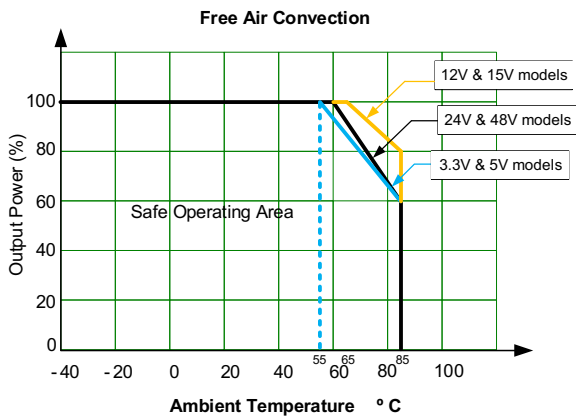

On/Off Control Application Circuit

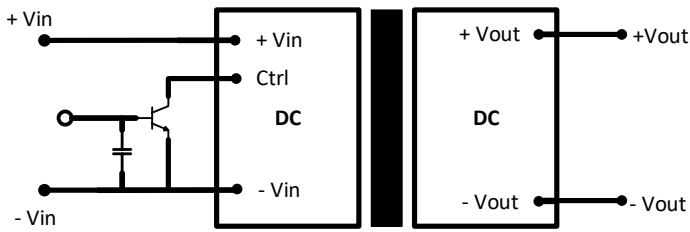

Typical Application Circuit

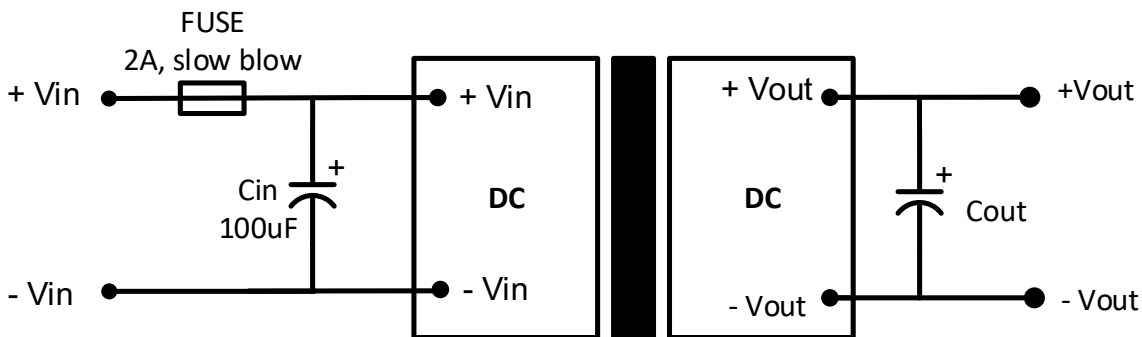

EMC recommended Circuit

For 3.3V, 5V, 12V, 15V, 24V output models

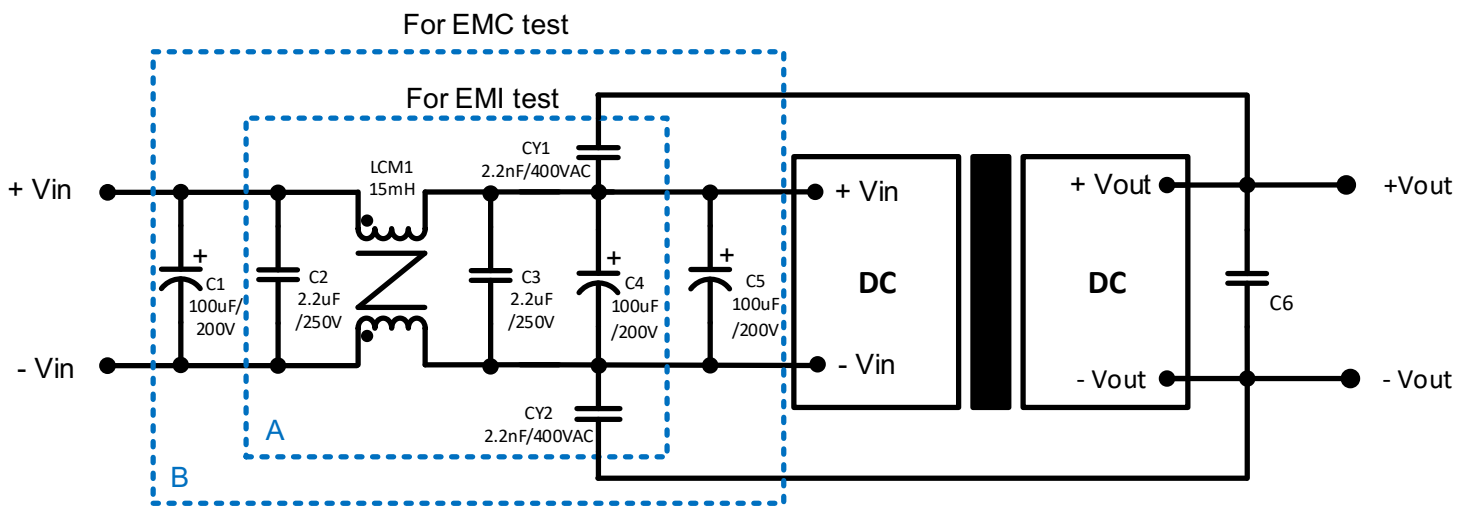

Notes: Part A for EMI filtering and Part B is used for EMC test.

For 48V output model

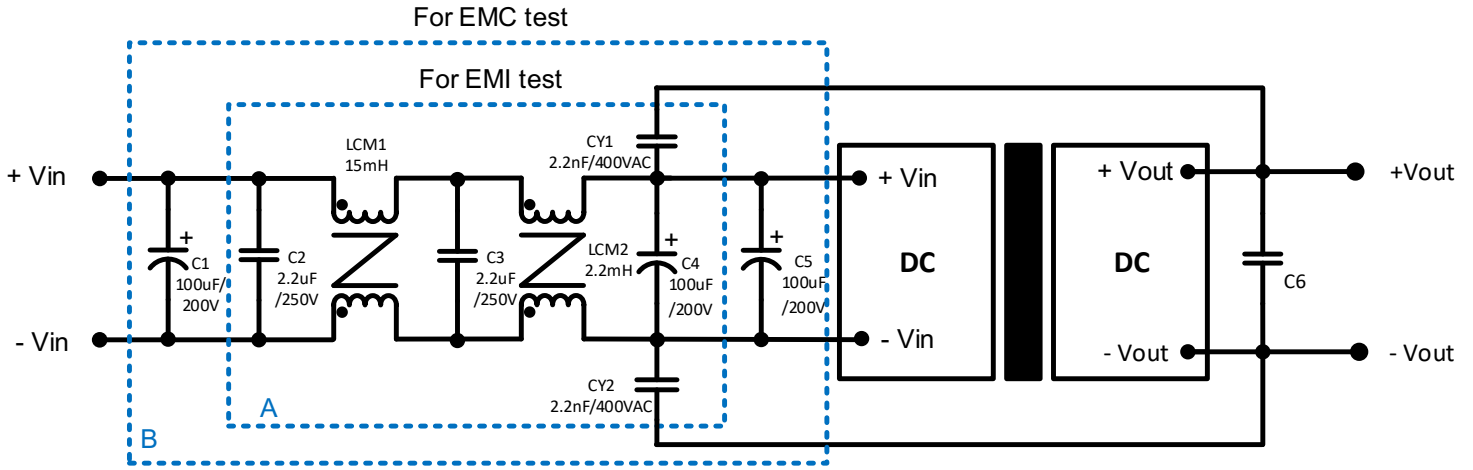

Notes: Part A for EMI filtering and Part B is used for EMC test.

Dimensions

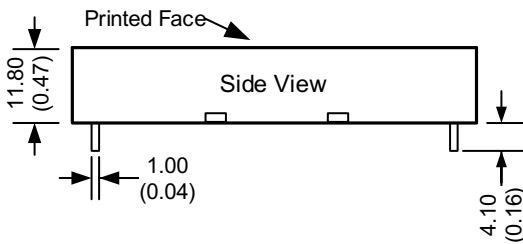
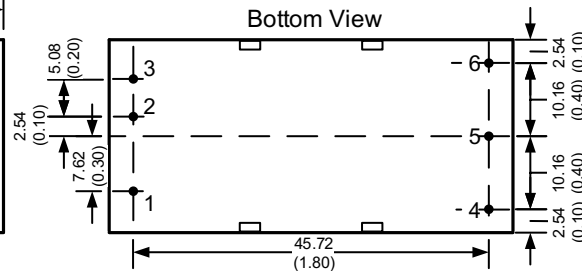
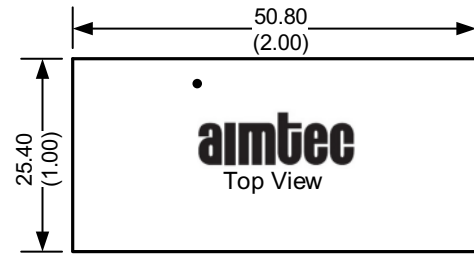

Note:
Unit: mm (inch)
Pin diameter tolerances: ± 0.10 (± 0.004)
General tolerances: ± 0.50 (± 0.02)

Pin Output Specifications	
Pin	Single
1	On/Off Ctrl
2	-V Input
3	+V Input
4	Trim
5	-V Output
6	+V Output

Dimensions with -K option

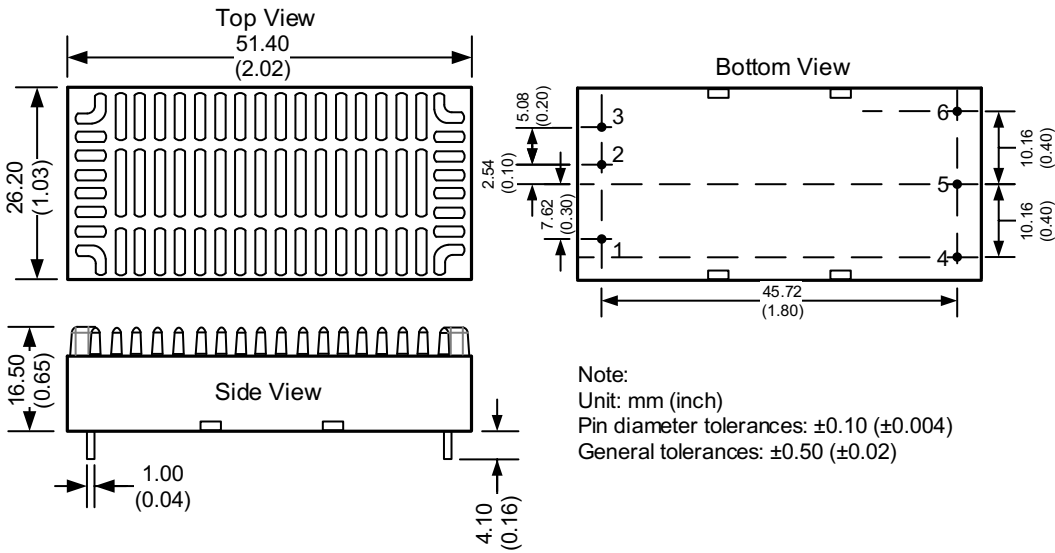

Pin Output Specifications	
Pin	Single
1	On/Off Ctrl
2	-V Input
3	+V Input
4	Trim
5	-V Output
6	+V Output

Dimensions with -ST option

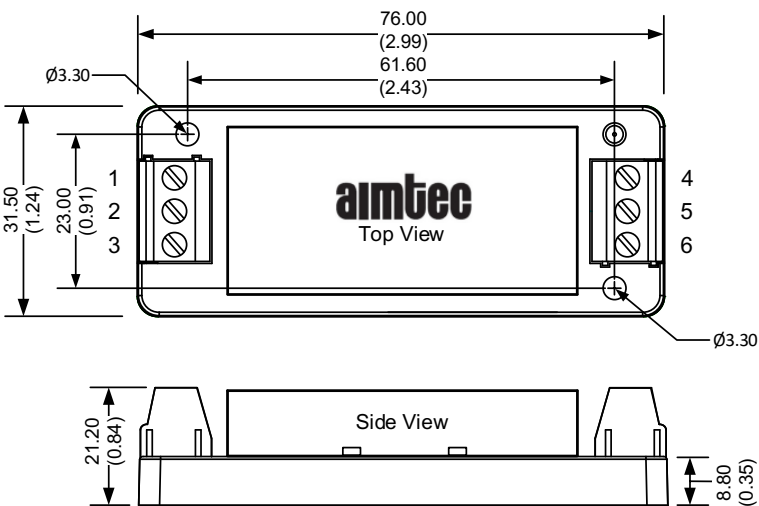

Pin Output Specifications	
Pin	Single
1	On/Off Ctrl
2	-V Input
3	+V Input
4	Trim
5	-V Output
6	+V Output

Note:
Unit: mm (inch)
Wire range: 24-12 AWG
Tightening torque: Max 0.4 N*m
General tolerances: ± 0.50 (± 0.02)

Dimensions with -K-ST option

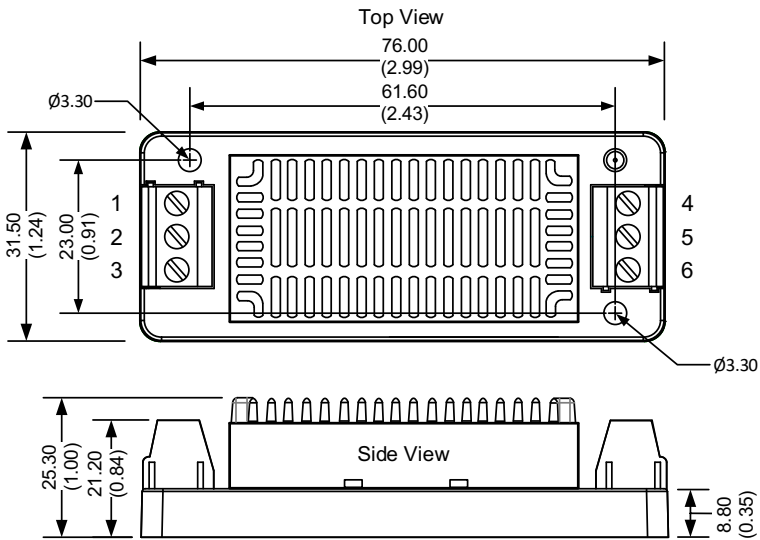

Pin Output Specifications	
Pin	Single
1	On/Off Ctrl
2	-V Input
3	+V Input
4	Trim
5	-V Output
6	+V Output

Note:
Unit: mm (inch)
Wire range: 24-12 AWG
Tightening torque: Max 0.4 N*m
General tolerances: ±1.00 (±0.04)

Dimensions with -STD option

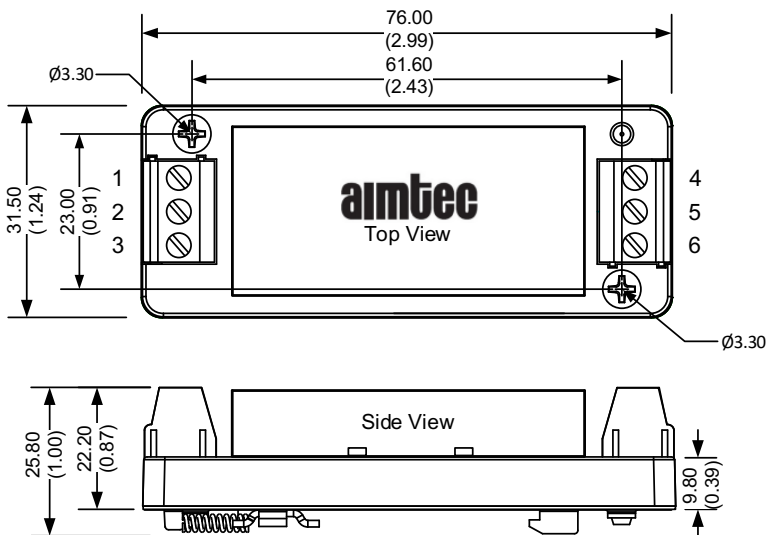

Pin Output Specifications	
Pin	Single
1	On/Off Ctrl
2	-V Input
3	+V Input
4	Trim
5	-V Output
6	+V Output

Note:
Unit: mm (inch)
Mounting rail: TS35
Wire range: 24-12 AWG
Tightening torque: Max 0.4 N*m
General tolerances: ±1.00 (±0.04)

Dimensions with -K-STD option

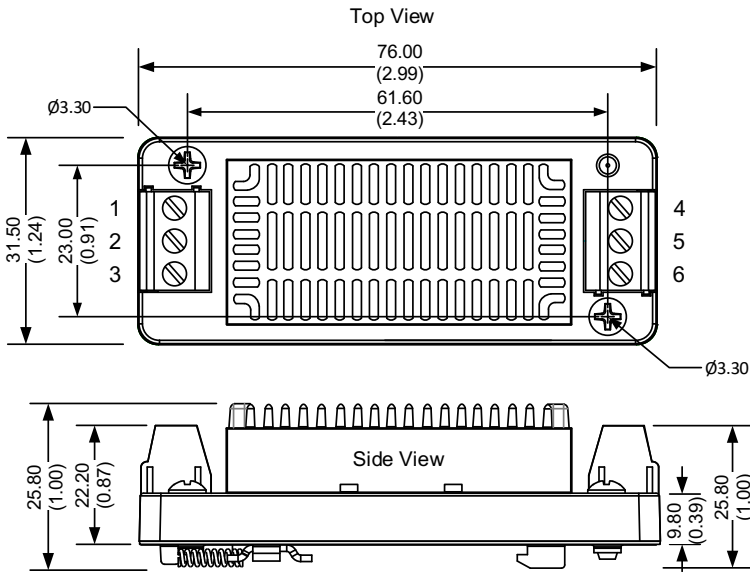

Pin Output Specifications	
Pin	Single
1	On/Off Ctrl
2	-V Input
3	+V Input
4	Trim
5	-V Output
6	+V Output

Note:
Unit: mm (inch)
Mounting rail: TS35
Wire range: 24-12 AWG
Tightening torque: Max 0.4 N*m
General tolerances: ± 1.00 (± 0.04)

Trimming

Output voltage can be externally trimmed by utilizing the methods as shown below

Fixed Resistor

Variable Potentiometer

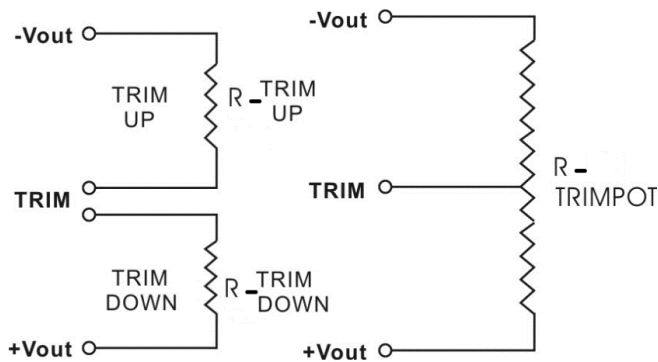

Leave open if not used.

AM40EW-11003SH30-NZ

Trim down %	1	2	3	4	5	6	7	8	9	10
Vout (VDC)	3.267	3.234	3.201	3.168	3.135	3.102	3.069	3.036	3.003	2.97
Rt down (KΩ)	195.744	109.218	73.096	53.27	40.741	32.108	25.797	20.983	17.19	14.124
Trim up %	1	2	3	4	5	6	7	8	9	10
Vout (VDC)	3.333	3.366	3.399	3.432	3.465	3.498	3.531	3.564	3.597	3.63
Rt up (KΩ)	308.349	105.149	60.286	40.58	29.504	22.407	17.472	13.842	11.058	8.857

AM40EW-11005SH30-NZ

Trim down %	1	2	3	4	5	6	7	8	9	10
Vout (VDC)	4.95	4.9	4.85	4.8	4.75	4.7	4.65	4.6	4.55	4.5
Rt down (KΩ)	105.181	52.154	31.997	21.378	14.823	10.373	7.155	4.719	2.811	1.277
Trim up %	1	2	3	4	5	6	7	8	9	10
Vout (VDC)	5.05	5.1	5.15	5.2	5.25	5.3	5.35	5.4	5.45	5.5
Rt up (KΩ)	176.356	71.279	41.974	28.2	20.198	14.967	11.281	8.544	6.43	4.749

AM40EW-11012SH30-NZ

Trim down %	1	2	3	4	5	6	7	8	9	10
Vout (VDC)	11.88	11.76	11.64	11.52	11.4	11.28	11.16	11.04	10.92	10.8
Rt down (KΩ)	496.092	301.452	212.527	161.585	128.573	105.442	88.332	75.164	64.716	56.223
Trim up %	1	2	3	4	5	6	7	8	9	10
Vout (VDC)	12.12	12.24	12.36	12.48	12.6	12.72	12.84	12.96	13.08	13.2
Rt up (KΩ)	706.435	158.92	83.879	54.075	38.077	28.095	21.274	16.317	12.552	9.595

AM40EW-11015SH30-NZ

Trim down %	1	2	3	4	5	6	7	8	9	10
Vout (VDC)	14.85	14.7	14.55	14.4	14.25	14.1	13.95	13.8	13.65	13.5
Rt down (KΩ)	974.008	517.39	346.387	256.863	201.789	164.487	137.551	117.187	101.251	88.44
Trim up %	1	2	3	4	5	6	7	8	9	10
Vout (VDC)	15.15	15.3	15.45	15.6	15.75	15.9	16.05	16.2	16.35	16.5
Rt up (KΩ)	283.713	117.996	70.541	48.045	34.918	26.315	20.242	15.725	12.235	9.456

AM40EW-11024SH30-NZ

Trim down %	1	2	3	4	5	6	7	8	9	10
Vout (VDC)	23.76	23.52	23.28	23.04	22.8	22.56	22.32	22.08	21.84	21.6
Rt down (KΩ)	1286.2	792.123	565.867	436.104	351.954	292.963	249.315	215.714	189.047	167.37
Trim up %	1	2	3	4	5	6	7	8	9	10
Vout (VDC)	24.24	24.48	24.72	24.96	25.2	25.44	25.68	25.92	26.16	26.4
Rt up (KΩ)	816.889	179.914	94.338	60.464	42.307	30.988	23.257	17.64	13.376	10.027

AM40EW-11048SH30-NZ

Trim down %	1	2	3	4	5	6	7	8	9	10
Vout (VDC)	47.52	47.04	46.56	46.08	45.6	45.12	44.64	44.16	43.68	43.2
Rt down (KΩ)	2357.74	1592.78	1193.77	948.808	783.113	663.569	573.251	502.609	445.845	399.235
Trim up %	1	2	3	4	5	6	7	8	9	10
Vout (VDC)	48.6	48.96	49.44	49.92	50.4	50.88	51.36	51.84	52.32	52.8
Rt up (KΩ)	4126	331.356	138.244	82.118	55.382	39.741	29.475	22.22	16.821	12.646

NOTE: **1.** Datasheets are updated as needed and as such, specifications are subject to change without notice. Once printed or downloaded, datasheets are no longer controlled by Aimtec; refer to www.aimtec.com for the most current product specifications. **2.** Product labels shown, including safety agency certifications on labels, may vary based on the date manufactured. **3.** Mechanical drawings and specifications are for reference only. **4.** All specifications are measured at an ambient temperature of 25°C, humidity<75%, nominal input voltage and at rated output load unless otherwise specified. **5.** Aimtec may not have conducted destructive testing or chemical analysis on all internal components and chemicals at the time of publishing this document. CAS numbers and other limited information are considered proprietary and may not be available for release. **6.** This product is not designed for use in critical life support systems, equipment used in hazardous environments, nuclear control systems or other such applications which necessitate specific safety and regulatory standards other the ones listed in this datasheet. **7.** Warranty is in accordance with Aimtec's standard Terms of Sale available at www.aimtec.com.