

High Accuracy Voltage Detector with Delay Function (Internal Counter Type)

No.EA-306-220901

OUTLINE

The RP300x is a voltage detector (VD) IC with a built-in output delay circuit. The RP300x is available in internally fixed detector threshold type. When the V_{DD} voltage becomes lower than the preset voltage, the RP300xxxxA/C generates a “L” reset signal and the RP300xxxxB⁽¹⁾ generates a “H” reset signal. The detector threshold accuracy is as high as $\pm 1.0\%$ when $-V_{SET}^{(2)} < 1.7\text{ V}$ and $\pm 0.8\%$ when $1.7\text{ V} \leq -V_{SET}$.

The reset output signal remains asserted for 50 ms, 100 ms⁽³⁾ or 200 ms after the V_{DD} voltage rises above the threshold voltage or when manual reset is canceled. The RP300x is designed to ignore fast transients on the V_{DD} pin. The output delay time accuracy is as high as $\pm 5.0\%$. The RP300x is available in an Nch open drain output type or in a CMOS output type. The RP300x is offered in a small DFN(PLP)1010-4B package or in a SOT-23-5 package.

FEATURES

- Operating Voltage Range (Maximum Rating).....0.72 V to 5.50 V (6.0V)
- Supply Current Typ. 0.95 μA ($-V_{SET} = 3.08\text{ V}$, $V_{DD} = 3.18\text{ V}$)
- Detector Threshold Range 1.1 V, 2.32 V, 2.63 V, 2.7 V, 2.8 V, 2.93 V, 3.08 V, 4.2 V, 4.38 V, 4.6 V
- Detector Threshold Accuracy $\pm 1.0\%$ ($-V_{SET} < 1.7\text{ V}$), $\pm 0.8\%$ ($1.7\text{ V} \leq -V_{SET}$)
- Detector Threshold Temperature Coefficient..... Typ. $\pm 50\text{ ppm}/^\circ\text{C}$
- Released Output Delay Time Typ. 50 ms, 100 ms (Custom IC), 200 ms
- Released Output Delay Time Accuracy $\pm 5\%$ ($T_a = 25^\circ\text{C}$), $\pm 15\%$ ($-40^\circ\text{C} \leq T_a \leq 85^\circ\text{C}$)
- Output Type Nch Open Drain output, CMOS Output
- Reset Signal Active-low, Active-high (Custom IC)
- Package..... DFN(PLP)1010-4B (1.0 mm x 1.0 mm x 0.6 mm)
SOT-23-5 (2.9 mm x 2.8 mm x 1.1 mm)

APPLICATIONS

- Voltage monitoring for handheld communication equipment, camera and VCRs.
- Voltage monitoring for battery-powered equipment

⁽¹⁾ RP300xxxxB is a custom IC. For more information about a custom IC, please contact our sales representatives.

⁽²⁾ $-V_{SET}$ is defined as a preset detector threshold.

⁽³⁾ Delay time of 100ms is offered as a custom IC.

SELECTION GUIDE

With the RP300x, the detector threshold, the package type, the released output delay time and the output type are user-selectable options.

Product Name	Package	Quantity per Reel	Pb Free	Halogen Free
RP300K _{xx} y*(z)-TR	DFN(PLP)1010-4B	10,000 pcs	Yes	Yes
RP300N _{xx} y*(z)-TR-FE	SOT-23-5	3,000 pcs	Yes	Yes

xx: Specify $-V_{SET}$ from 1.1 V (11), 2.32 V (23), 2.63 V (26), 2.7 V (27), 2.8 V (28), 2.93 V (29), 3.08 V (30), 4.2 V (42), 4.38 V (43), 4.6 V (46).

z: If $-V_{SET}$ includes the 3rd digit, indicate the digit of 0.01 V.
 Ex. If $-V_{SET}$ is 2.63 V, indicate as RP300x26xx3-TR-x.

y: Specify the released output delay time.

- (A) 50 ms
- (B) 100 ms (custom IC)
- (D) 200 ms

*: Specify the output type.

- (A) Nch Open Drain Output
- (B) Nch Open Drain Inverting Output (custom IC)
- (C) CMOS Output

BLOCK DIAGRAMS

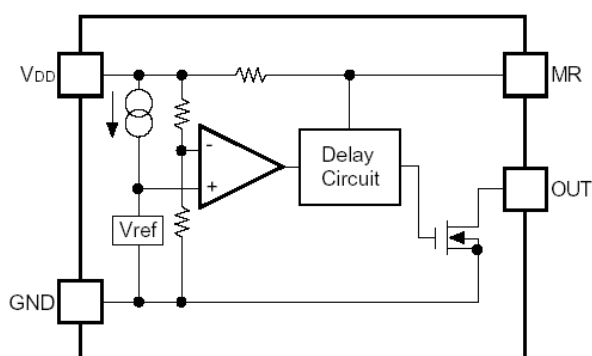

RP300xxxxA/B (Nch Open Drain Output)

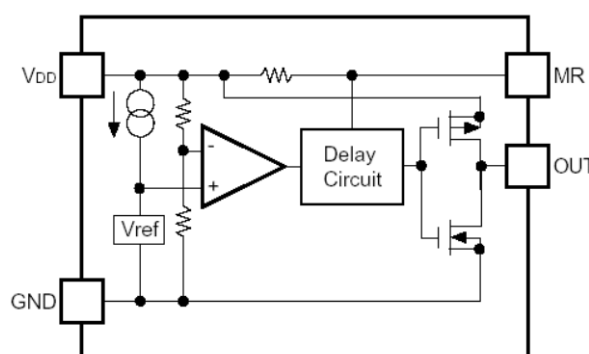

RP300xxxxC (CMOS Output)

PIN DESCRIPTION

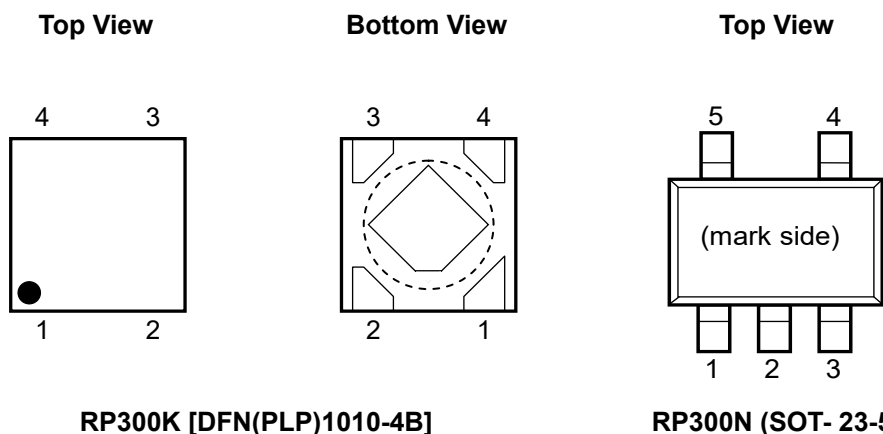

RP300K Pin Description

Pin No.	Symbol	Pin Description
1	OUT	Output Pin RP300xxxxA/C: asserts an active-low reset signal when a voltage drops below the detector threshold. RP300xxxxB: asserts an active-high reset signal when a voltage drops below the detector threshold. (custom IC)
2	MR	Manual Reset Input Pin: active-low
3	GND	Ground Pin
4	VDD	Power Supply Pin

The tab on the bottom of the package enhances thermal performance and is electrically connected to GND (substrate level). It is recommended that the tab be connected to the ground plane on the board. If not, the tab can be left open.

RP300N Pin Description

Pin No.	Symbol	Description
1	MR	Manual Reset Input Pin: active-low
2	GND	Ground Pin
3	NC	No Connection
4	OUT	Output Pin RP300xxxxA/C: asserts an active-low reset signal when a voltage drops below the detector threshold. RP300xxxxB: asserts an active-high reset signal when a voltage drops below the detector threshold. (custom IC)
5	VDD	Power Supply Pin

ABSOLUTE MAXIMUM RATINGS

Symbol	Parameter		Rating	Unit
V _{IN}	Input Voltage		6.0	V
OUT	Output Voltage (Nch Open Drain Output)		-0.3 to 6.0	V
	Output Voltage (CMOS Output)		-0.3 to V _{DD} +0.3	
MR	Manual Reset Pin		-0.3 to V _{DD} +0.3	V
I _{OUT}	Output Current		20	mA
P _D	Power Dissipation ⁽¹⁾ (JEDEC STD. 51-7)	DFN(PLP)1010-4B	800	mW
		SOT-23-5	660	
T _j	Junction Temperature Range		-40 to 125	°C
T _{stg}	Storage Temperature Range		-55 to 125	°C

ABSOLUTE MAXIMUM RATINGS

Electronic and mechanical stress momentarily exceeded absolute maximum ratings may cause the permanent damages and may degrade the life time and safety for both device and system using the device in the field. The functional operation at or over these absolute maximum ratings are not assured.

RECOMMENDED OPERATING CONDITIONS

Symbol	Parameter	Rating	Unit
V _{DD}	Operating Voltage	0.72 to 5.5	V
T _a	Operating Temperature Range	-40 to 85	°C

RECOMMENDED OPERATING CONDITIONS

All of electronic equipment should be designed that the mounted semiconductor devices operate within the recommended operating conditions. The semiconductor devices cannot operate normally over the recommended operating conditions, even if when they are used over such conditions by momentary electronic noise or surge. And the semiconductor devices may receive serious damage when they continue to operate over the recommended operating conditions.

⁽¹⁾ Refer to *POWER DISSIPATION* for detailed information.

ELECTRICAL CHARACTERISTICS

The specifications surrounded by are guaranteed by design engineering at $-40^{\circ}\text{C} \leq T_a \leq 85^{\circ}\text{C}$.

RP300x Electrical Characteristics

($T_a = 25^{\circ}\text{C}$)

Symbol	Parameter	Condition	Min.	Typ.	Max.	Unit	
$-V_{\text{DET}}$	Detector Threshold ⁽¹⁾	$T_a = 25^{\circ}\text{C}$	$1.1\text{ V} \leq -V_{\text{SET}} < 1.7\text{ V}$	$\times 0.99$		$\times 1.010$	V
			$1.7\text{ V} \leq -V_{\text{SET}}$	$\times 0.992$		$\times 1.008$	V
		$-40^{\circ}\text{C} \leq T_a \leq 85^{\circ}\text{C}$	$1.1\text{ V} \leq -V_{\text{SET}} < 1.7\text{ V}$	0.982		1.018	V
			$1.7\text{ V} \leq -V_{\text{SET}}$	0.984		1.016	V
I_{SS1}	Supply Current 1	$V_{\text{DD}} = -V_{\text{SET}} - 0.1\text{ V}$, $I_{\text{OUT}} = 0\text{ A}$			3.2	μA	
I_{SS2}	Supply Current 2	$V_{\text{DD}} = -V_{\text{SET}} + 0.1\text{ V}$, $I_{\text{OUT}} = 0\text{ A}$			3.1	μA	
V_{DD}	Operating Voltage	$T_a = 25^{\circ}\text{C}$	0.72		5.5	V	
		$-40^{\circ}\text{C} \leq T_a \leq 85^{\circ}\text{C}$	0.80		5.5	V	
I_{OUT}	Output Current (Driver Output Pin)	Nch $V_{\text{DD}} = -V_{\text{SET}} - 0.1\text{ V}$ $V_{\text{DS}} = 0.3\text{ V}$	$-V_{\text{SET}} \geq 1.1\text{ V}$	0.45			mA
			$-V_{\text{SET}} \geq 1.6\text{ V}$	2.5			mA
			$-V_{\text{SET}} \geq 2.7\text{ V}$	4.8			mA
		Nch Inverting ⁽²⁾ $V_{\text{DD}} = -V_{\text{SET}} + 0.1\text{ V}$ $V_{\text{DS}} = 0.3\text{ V}$	$-V_{\text{SET}} \geq 1.1\text{ V}$	0.45			mA
			$-V_{\text{SET}} \geq 1.4\text{ V}$	2.5			mA
			$-V_{\text{SET}} \geq 2.5\text{ V}$	4.8			mA
		Pch CMOS $V_{\text{DD}} = -V_{\text{SET}} + 0.1\text{ V}$ $V_{\text{DS}} = -0.3\text{ V}$	$-V_{\text{SET}} \geq 1.1\text{ V}$	-0.15			mA
			$-V_{\text{SET}} \geq 1.6\text{ V}$	-0.45			mA
			$-V_{\text{SET}} \geq 2.7\text{ V}$	-0.8			mA
I_{LEAK}	Nch Driver Leakage Current	RP300xxxxA/C $V_{\text{DD}} = 5.5\text{ V}$ $V_{\text{DS}} = 5.5\text{ V}$			0.15	μA	
		RP300xxxxB ⁽³⁾ $V_{\text{DD}} = -V_{\text{SET}} - 0.1\text{ V}$ $V_{\text{DS}} = 5.5\text{ V}$					
R_{MR}	MR Pin Pull-up Resistance		0.21	0.45	0.90	$\text{M}\Omega$	
V_{IH}	MR Pin Input Voltage "H"	$V_{\text{DD}} \geq -V_{\text{SET}} + 0.1\text{ V}$	0.75 $\times V_{\text{DD}}$			V	
V_{IL}	MR Pin Input Voltage "L"	$V_{\text{DD}} \geq -V_{\text{SET}} + 0.1\text{ V}$			0.4	V	
t_{DELAY}	Released Output Delay Time ⁽⁴⁾	$V_{\text{DD}} = 0.8\text{ V} \rightarrow -V_{\text{SET}} + 1.0\text{ V}$	RP300xxxAx	47.5	50	52.5	ms
			RP300xxxBx ⁽⁵⁾	95	100	105	
			RP300xxxDx	190	200	210	
		$-40^{\circ}\text{C} \leq T_a \leq 85^{\circ}\text{C}$		tSET $\times 0.85$		tSET $\times 1.15$	%
$\Delta -V_{\text{DET}} / \Delta T_a$	Detector Threshold Temperature Coefficient	$-40^{\circ}\text{C} \leq T_a \leq 85^{\circ}\text{C}$		± 50		ppm/ $^{\circ}\text{C}$	

All test items listed under Electrical Characteristics are done under the pulse load condition ($T_j \approx T_a = 25^{\circ}\text{C}$) except Detector Threshold Temperature Coefficient.

(1) $-V_{\text{DET}}$ is defined as an actual detector threshold and $-V_{\text{SET}}$ is defined as a preset detector threshold.

(2) Nch open drain inverting output type is only applicable to the RP300xxxxB which is a custom IC.

(3) The RP300xxxxB is a custom IC.

(4) t_{DELAY} is defined as an actual released output delay time and t_{SET} is defined as a preset released output delay time.

(5) The RP300xxxBx is a custom IC.

Product-specific Electrical Characteristics

The specifications surrounded by are guaranteed by design engineering at $-40^{\circ}\text{C} \leq T_a \leq 85^{\circ}\text{C}$.

Product Name	-V_{DET} [V]					
	T_a = 25°C			-40°C ≤ T_a ≤ 85°C		
	Min.	Typ.	Max.	Min.	Typ.	Max.
RP300x11xx	1.089	1.100	1.111	1.081	1.100	1.119
RP300x23xx2	2.302	2.320	2.338	2.283	2.320	2.357
RP300x26xx3	2.609	2.630	2.651	2.588	2.630	2.672
RP300x27xx	2.679	2.700	2.721	2.657	2.700	2.743
RP300x28xx	2.778	2.800	2.822	2.756	2.800	2.844
RP300x29xx3	2.907	2.930	2.953	2.884	2.930	2.976
RP300x30xx8	3.056	3.080	3.104	3.031	3.080	3.129
RP300x42xx	4.167	4.200	4.233	4.133	4.200	4.267
RP300x43xx8	4.345	4.380	4.415	4.310	4.380	4.450
RP300x46xx	4.564	4.600	4.636	4.527	4.600	4.673

THEORY OF OPERATION

Timing Chart

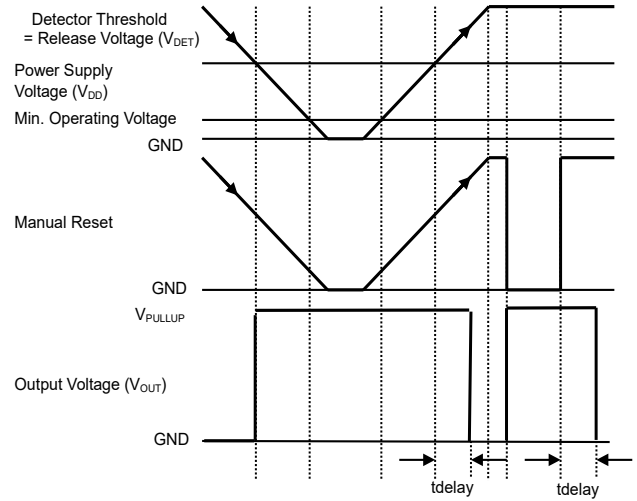
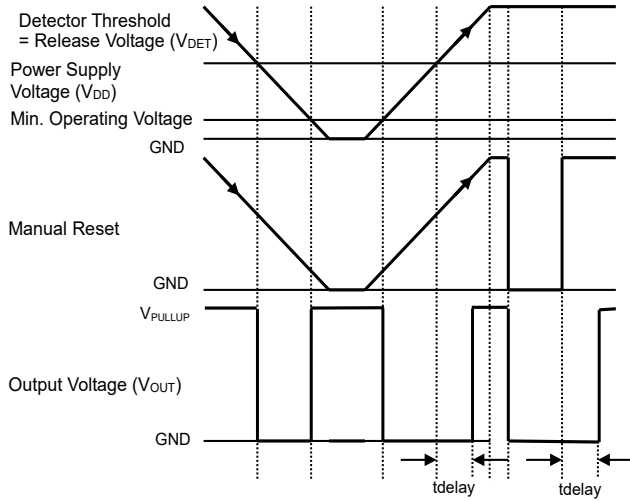

RP300xxxA Timing Chart

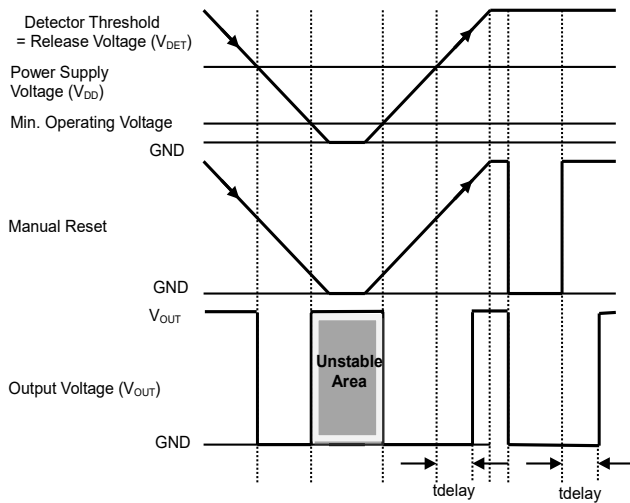

RP300xxxC Timing Chart

RP300xxxB Timing Chart

Release Output Delay Time (t_{DELAY})

t_{DELAY} is defined as follows.

1. Nch Open Drain Output

Release output delay time starts after the OUT pin is pulled up to 5.5 V with a 470 kΩ resistor, and the V_{DD} voltage is shifted from 0.8 V to $-V_{SET} + 1.0$ V. It ends when the output voltage reaches 1.0 V.

2. Nch Open Drain Inverting Output (custom IC)

Release output delay time starts after the OUT pin is pulled up to 5.5 V with a 470 kΩ resistor, and the V_{DD} voltage is shifted from 0.8 V to $-V_{SET} + 1.0$ V. It ends when the output voltage reaches $V_{DD} / 2$ V.

3. CMOS Output

Release output delay time starts when the V_{DD} voltage is shifted from 0.8 V to $-V_{SET} + 1.0$ V and ends when the output voltage reaches $V_{DD} / 2$ V.

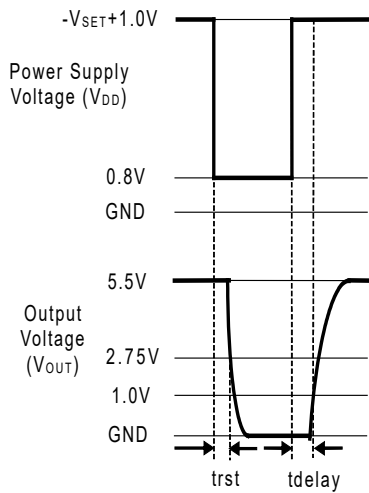

Nch Open Drain Output

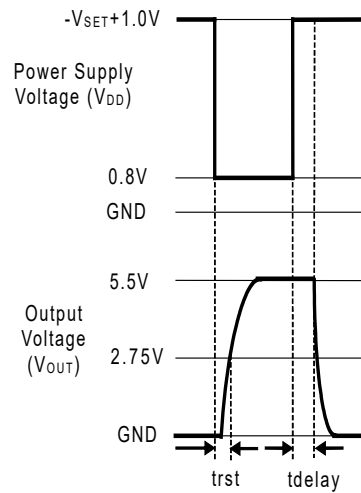

Nch Open Drain Inverting Output

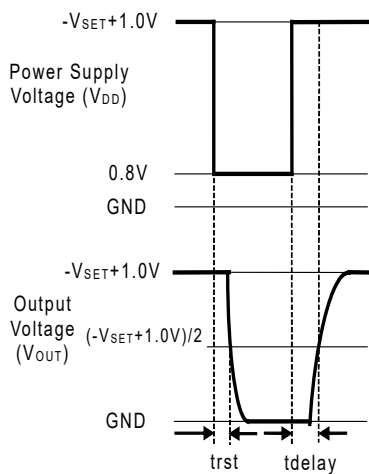

CMOS Output

RP300xxxxA/C Operating

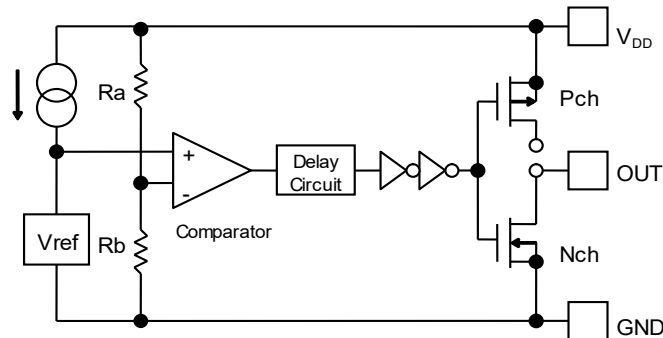

Block Diagram

- For CMOS Output, the Nch Tr. drain and the Pch Tr. drain are connected to the OUT pin inside the IC.
- For Nch Open Drain Output, the Nch Tr. drain is connected to the OUT pin inside the IC. Pull up the OUT pin or V_{DD} pin to the external voltage level.

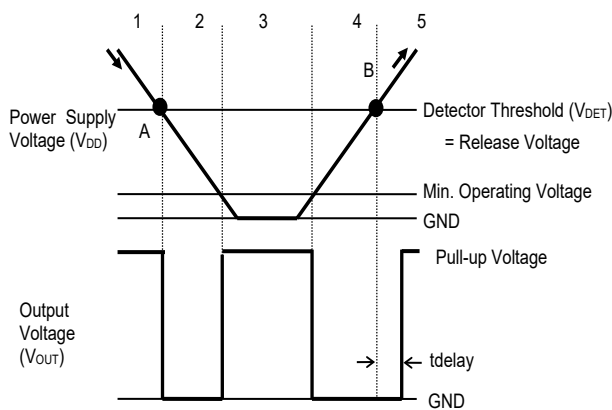

Timing Chart (A Ver.)

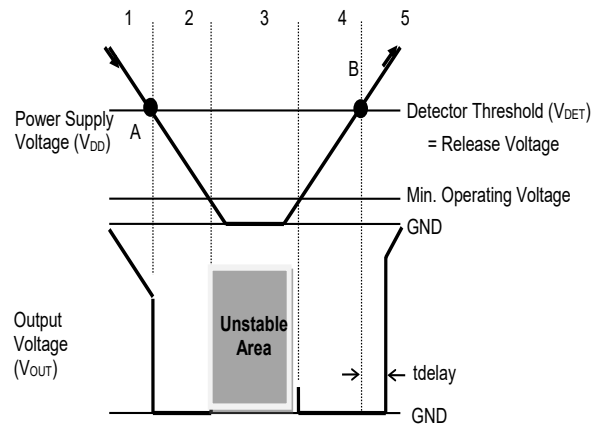

Timing Chart (C Ver.)

1. The output voltage is equalized to the V_{DD} voltage (CMOS Output), or to the pull-up voltage (Nch Open Drain Output).
2. The V_{DD} voltage drops to the detector threshold (A point) which means $V_{ref} \geq V_{DD} \times R_b / (R_a + R_b)$. The comparator output shifts from “L” to “H” voltage and the output voltage will be equalized to the GND voltage.
3. If the V_{DD} voltage is lower than the minimum operating voltage, the output voltage becomes unstable (CMOS Output). The output voltage is equalized to the pull-up voltage (Nch Open Drain Output).
4. The output voltage is equalized to the GND voltage.
5. The V_{DD} voltage becomes higher than the release voltage (B point) which means $V_{ref} < V_{DD} \times R_b / (R_a + R_b)$, and the comparator output shifts from “H” to “L” voltage, and the output voltage is equalized to the V_{DD} voltage (CMOS Output) or to the pull-up voltage (Nch Open Drain Output).

Note: There's no hysteresis between the V_{DD} voltage and the released voltage.

RP300xxxxB Operating

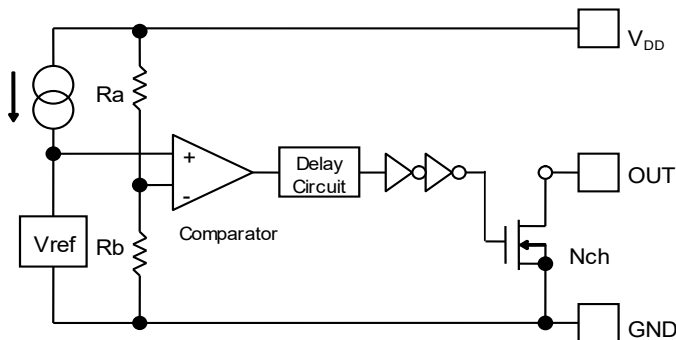

Block Diagram

- The Nch Tr. drain is connected to the OUT pin inside the IC. Pull up the OUT pin or VDD pin to the external voltage level.

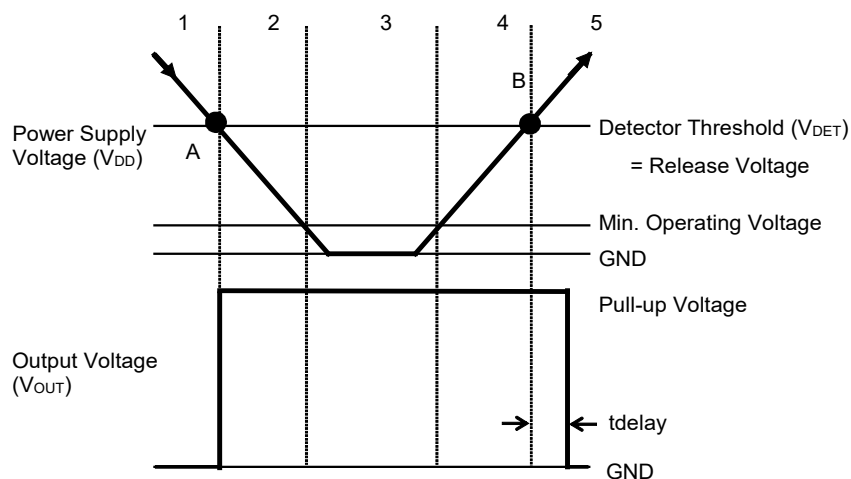

Timing Chart

1. The output voltage is equalized to the GND voltage.
2. The VDD voltage drops to the detector threshold (A point) which means $V_{ref} \geq V_{DD} \times R_b / (R_a + R_b)$. The comparator output shifts from "H" to "L" voltage and the output voltage shifts from the pull-up voltage to "L" voltage.
3. If the VDD voltage is lower than the minimum operating voltage, the output voltage is equalized to the pull-up voltage.
4. The output voltage is equalized to the pull-up voltage.
5. The VDD voltage becomes higher than the release voltage (B point) which means $V_{ref} < V_{DD} \times R_b / (R_a + R_b)$. The comparator output shifts from "L" to "H" voltage, and the output voltage is equalized to the GND voltage.

Note: There's no hysteresis between the VDD voltage and the released voltage.

Detector Operation vs. Glitch Input Voltage

The RP300x has built-in rejection of fast transients on the V_{DD} pins. The rejection of transients depends on both the duration and the amplitude of the transient. The amplitude of the transient is measured from the bottom of the transient to the negative threshold voltage of the RP300x.

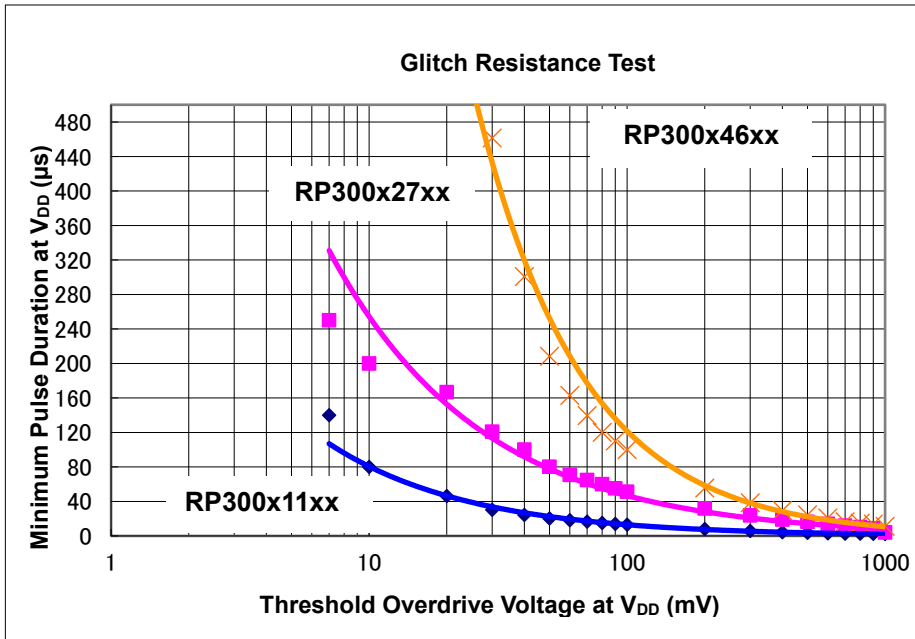

Minimum Pulse Duration at V_{DD} vs. Overdrive Voltage at V_{DD}

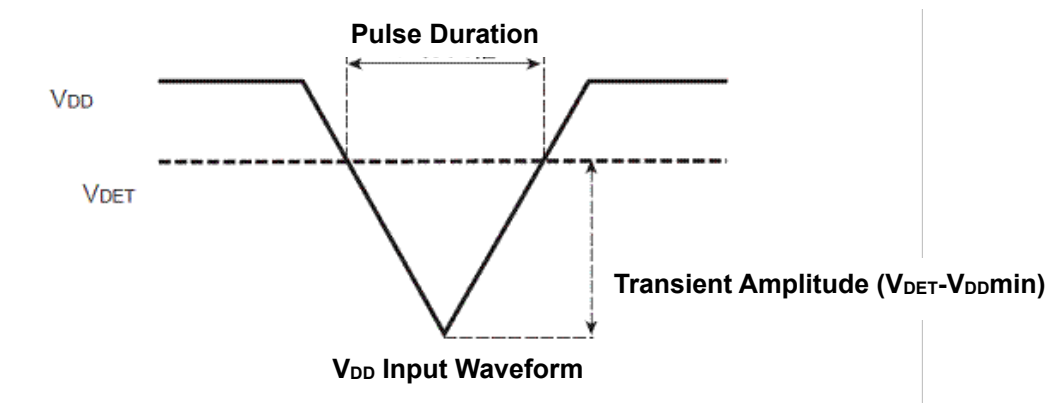

Voltage Transient Measurement

The RP300x does not respond to transients that are fast duration/ low amplitude or long duration/ small amplitude. The above graph shows the relationship between the transient amplitude and duration needed to trigger a reset. Any combination of duration and amplitude above the curve generates a reset signal.

APPLICATION INFORMATION

Typical Applications

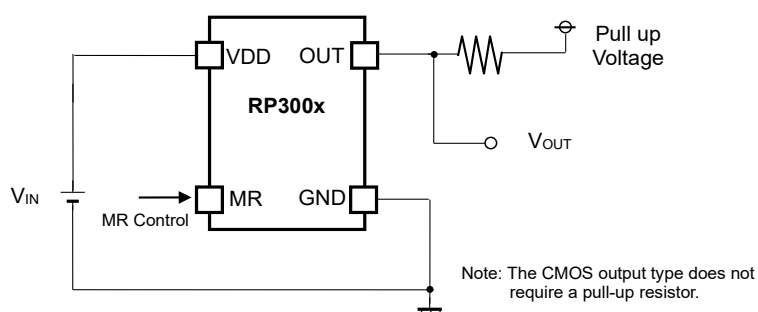

RP300x Typical Application Circuit

TECHNICAL NOTES

When connecting resistors to the device's input pin

When connecting a resistor (R1) to an input of this device, the input voltage decreases by [Device's Consumption Current] x [Resistance Value] only. And, the cross conduction current⁽¹⁾, which occurs when changing from the detecting state to the release state, is decreased the input voltage by [Cross Conduction Current] x [Resistance Value] only. And then, this device will enter the re-detecting state if the input voltage reduction is larger than the difference between the detector voltage and the released voltage.

When the input resistance value is large and the VDD is gone up at mildly in the vicinity of the released voltage, repeating the above operation may result in the occurrence of output.

As shown in Figure A/B, set R1 to become 100kΩ or less as a guide, and connect C_{IN}⁽²⁾ of 0.1μF and more to between the input pin and GND. Besides, make evaluations including temperature properties under the actual usage condition, with using the evaluation board like this way. As result, make sure that the cross conduction current has no problem.

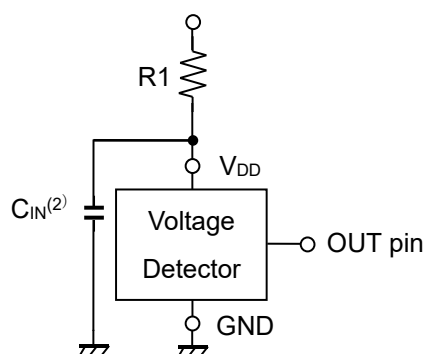

Figure A

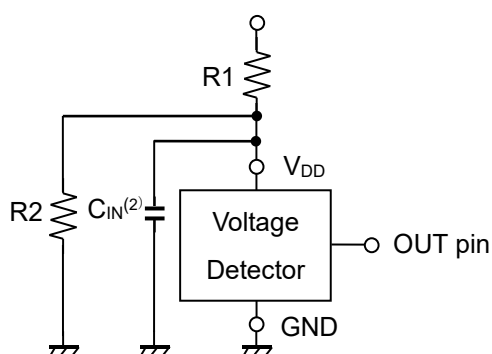

Figure B

⁽¹⁾ In the CMOS output type, a charging current for OUT pin is included.

⁽²⁾ Note the bias dependence of capacitors.

TYPICAL CHARACTERISTICS

Note: Typical Characteristics are intended to be used as reference data; they are not guaranteed.

1) Supply Current vs. Input Voltage

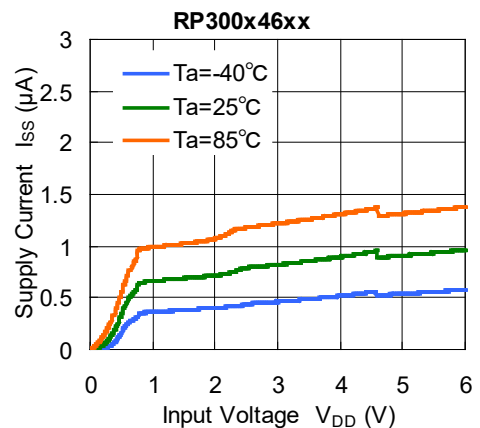
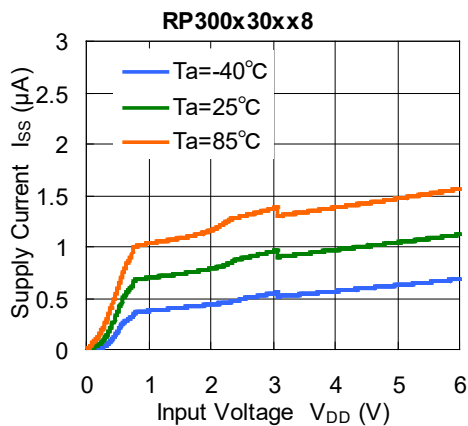
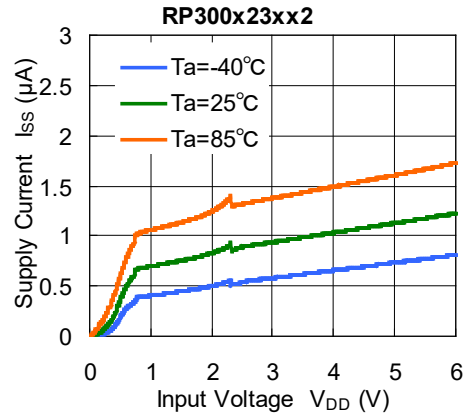
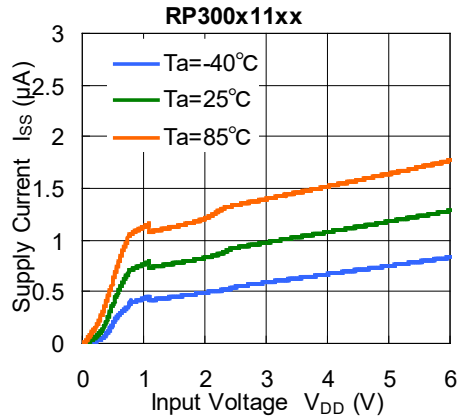

2) Detector Threshold vs. Temperature

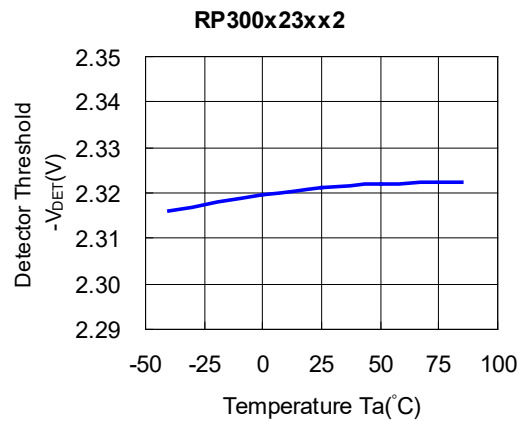
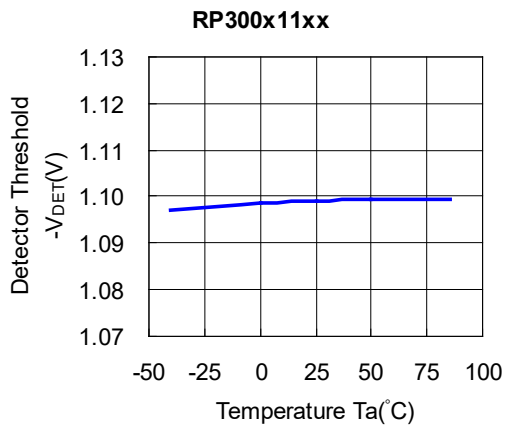

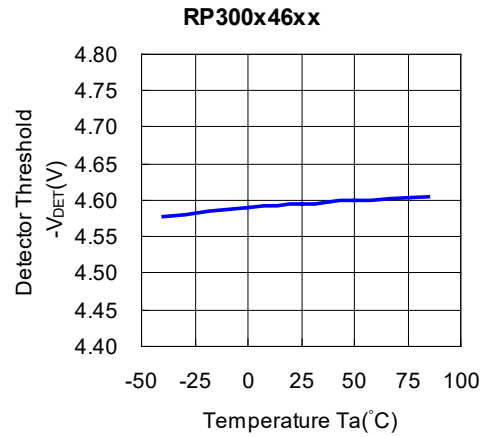
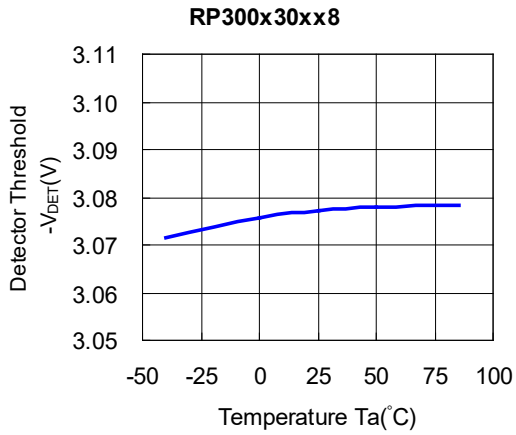

3) Nch Driver Output Current vs. Input Voltage

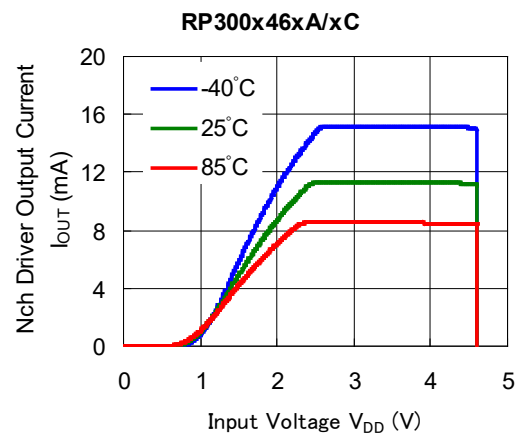
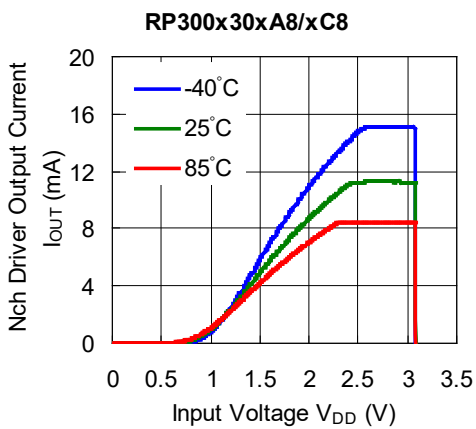
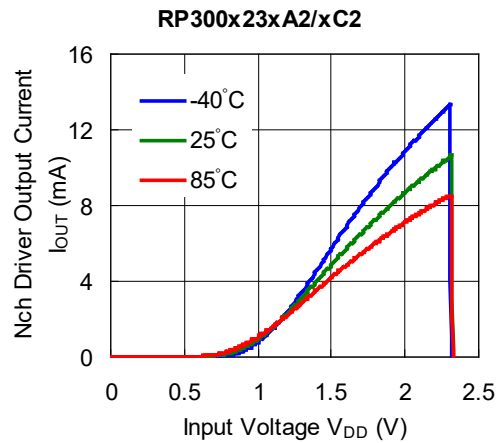
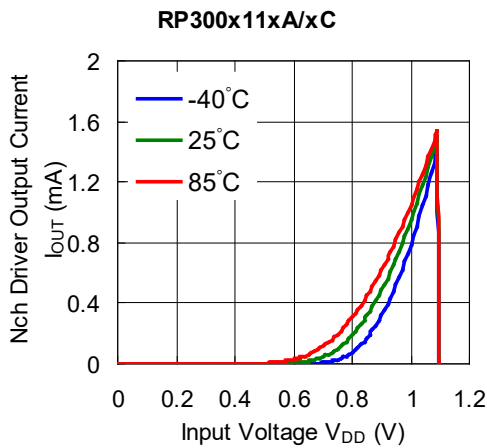

Nch Driver Inverting Output (custom IC)

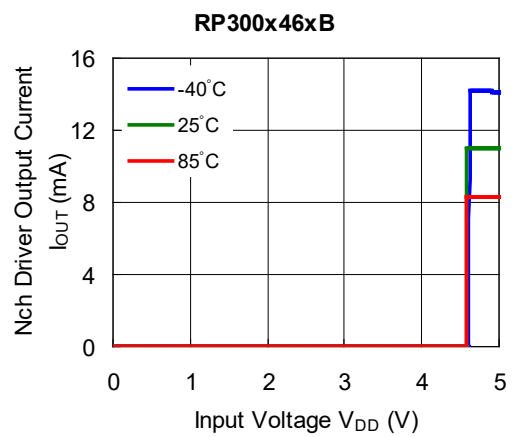
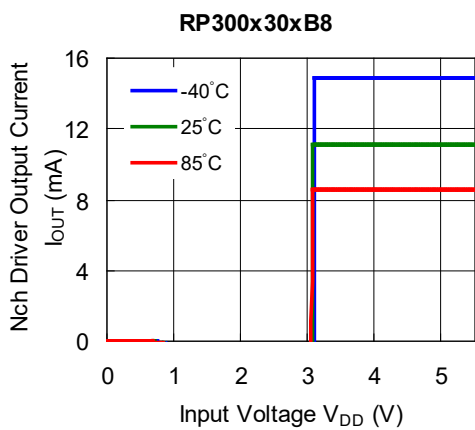
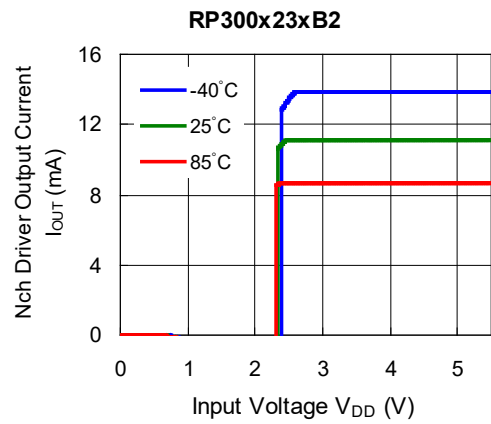
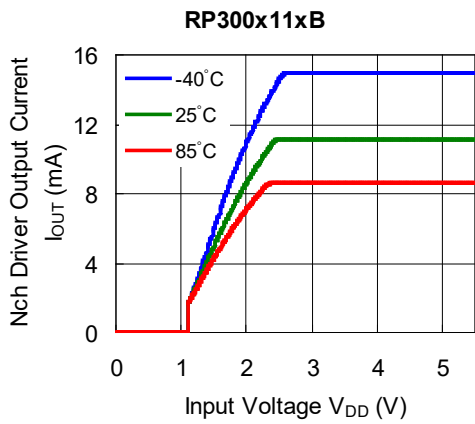

4) Pch Driver Output Current vs. Input Voltage

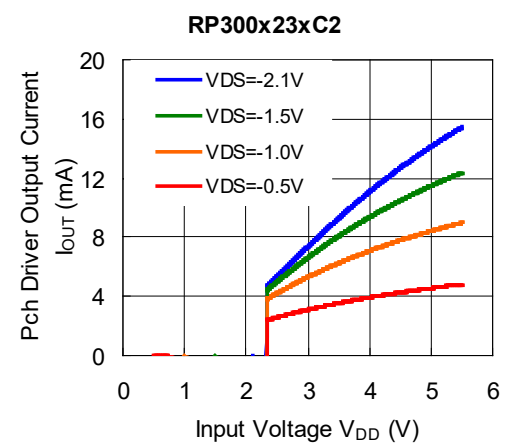
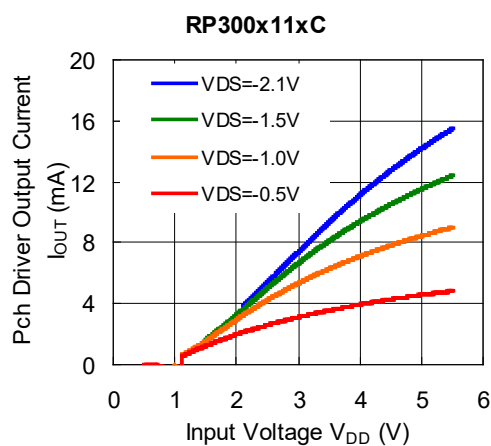

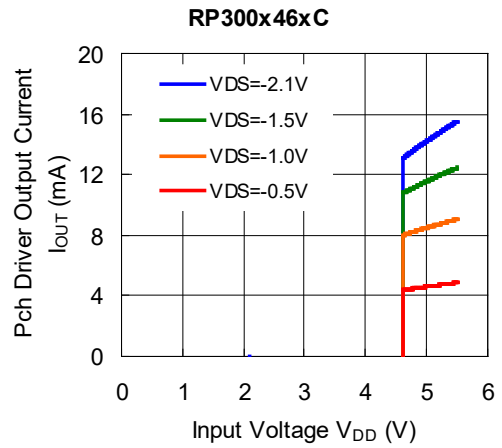
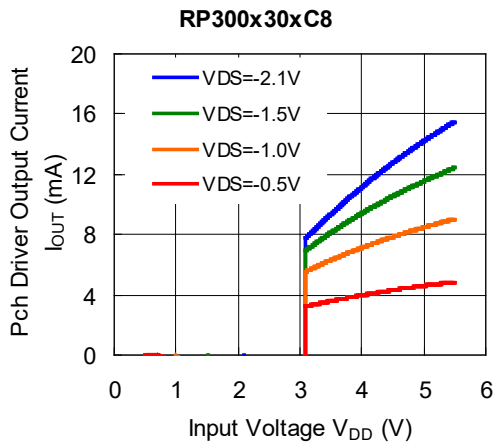

5) Nch Driver Output Current vs. V_{DS}

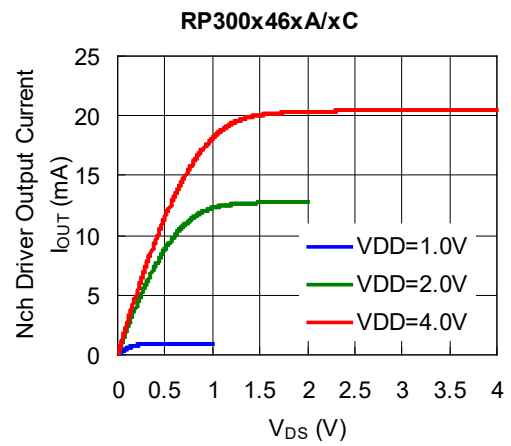
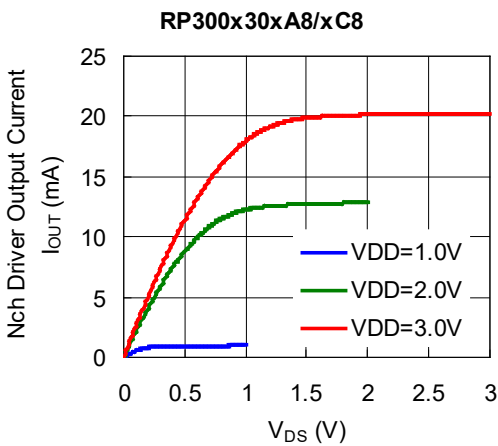
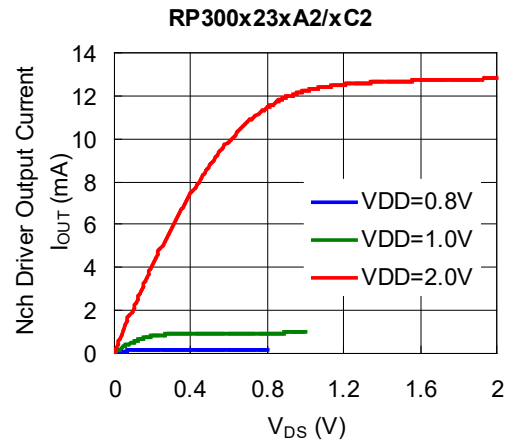
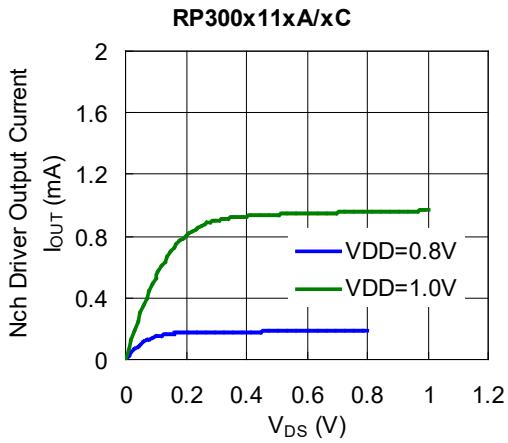

Nch Driver Inverting Output (custom IC)

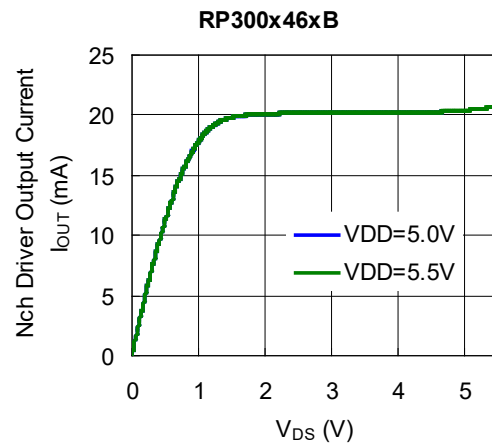
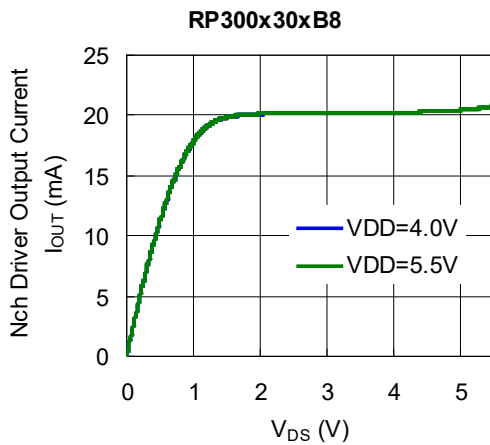
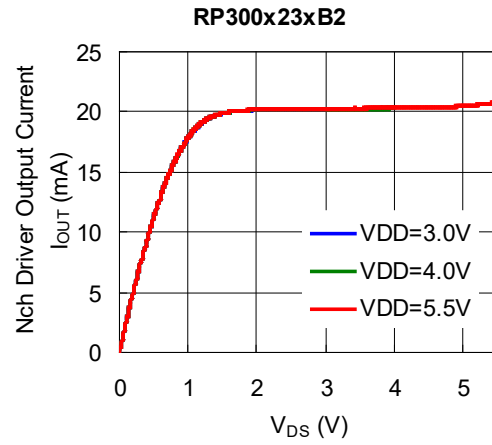
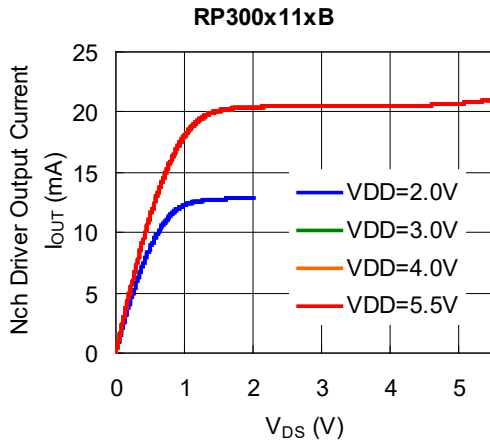

6) Released Output Delay Time vs. Temperature

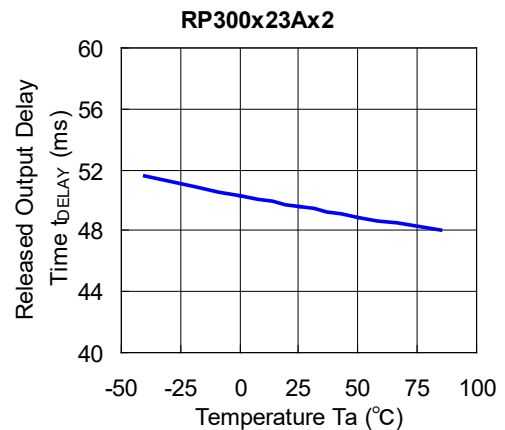
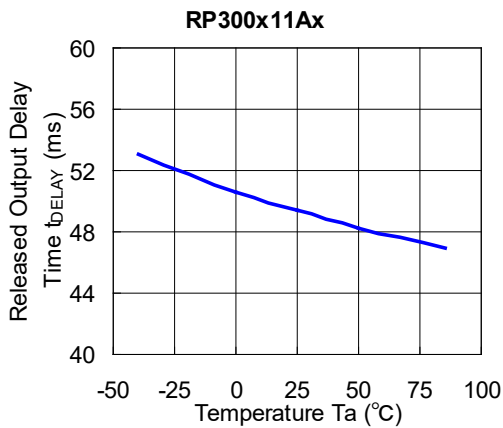

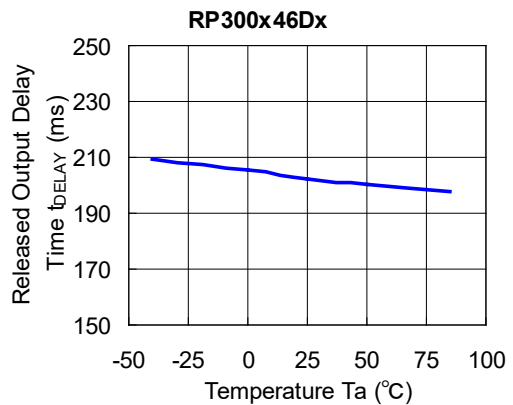
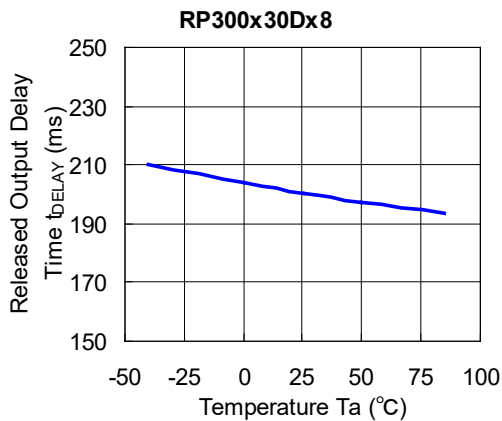
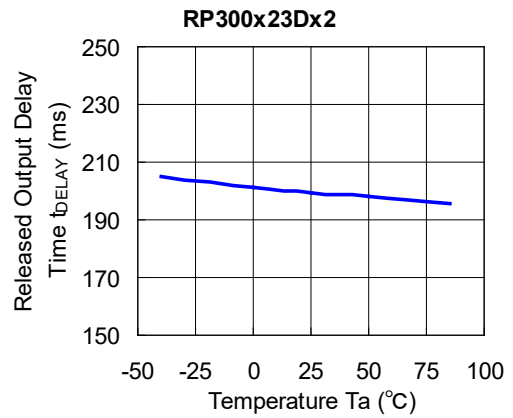
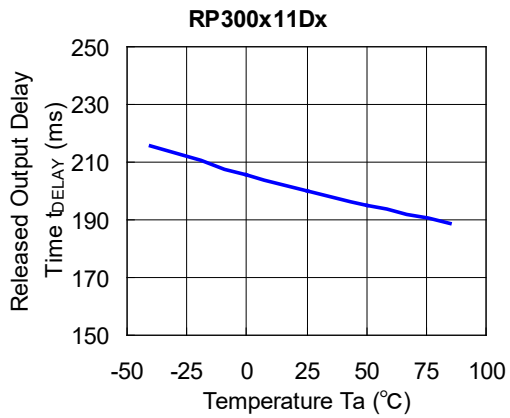
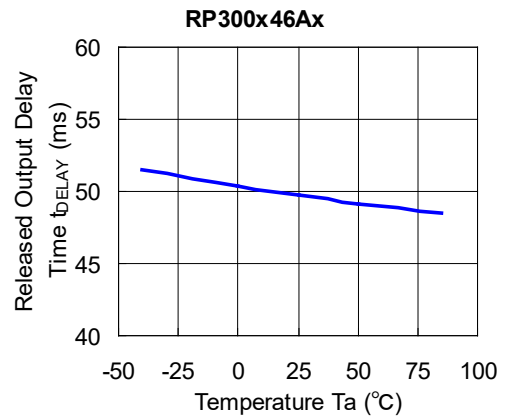
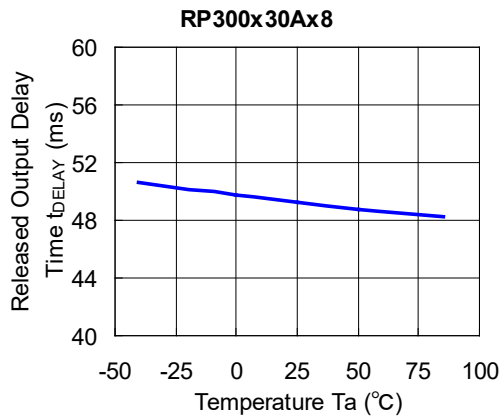

The power dissipation of the package is dependent on PCB material, layout, and environmental conditions. The following measurement conditions are based on JEDEC STD. 51-7.

Measurement Conditions

Item	Measurement Conditions
Environment	Mounting on Board (Wind Velocity = 0 m/s)
Board Material	Glass Cloth Epoxy Plastic (Four-Layer Board)
Board Dimensions	76.2 mm × 114.3 mm × 0.8 mm
Copper Ratio	Outer Layer (First Layer): Less than 95% of 50 mm Square Inner Layers (Second and Third Layers): Approx. 100% of 50 mm Square Outer Layer (Fourth Layer): Approx. 100% of 50 mm Square
Through-holes	φ 0.2 mm × 11 pcs

Measurement Result

(Ta = 25°C, Tjmax = 125°C)

Item	Measurement Result
Power Dissipation	800 mW
Thermal Resistance (θja)	θja = 125°C/W
Thermal Characterization Parameter (ψjt)	ψjt = 58°C/W

θja: Junction-to-Ambient Thermal Resistance

ψjt: Junction-to-Top Thermal Characterization Parameter

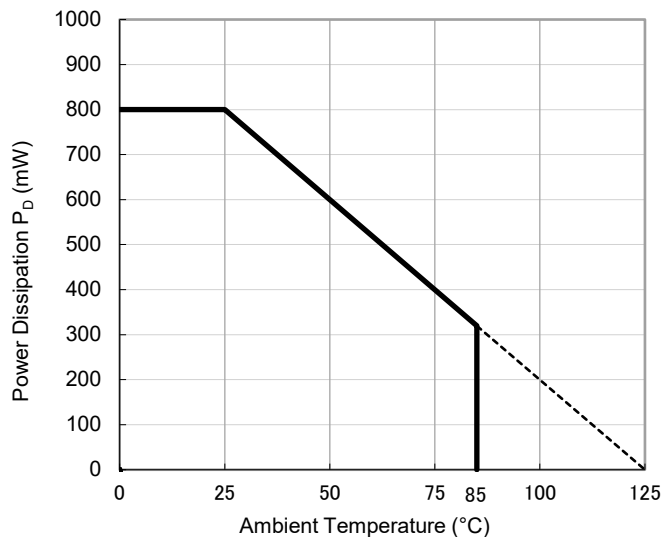

Power Dissipation vs. Ambient Temperature

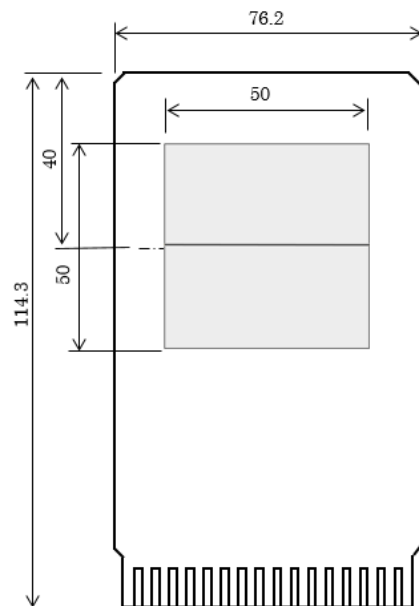

Measurement Board Pattern

PACKAGE DIMENSIONS

DFN(PLP)1010-4B

DM-DFN(PLP)1010-4B-JE-B

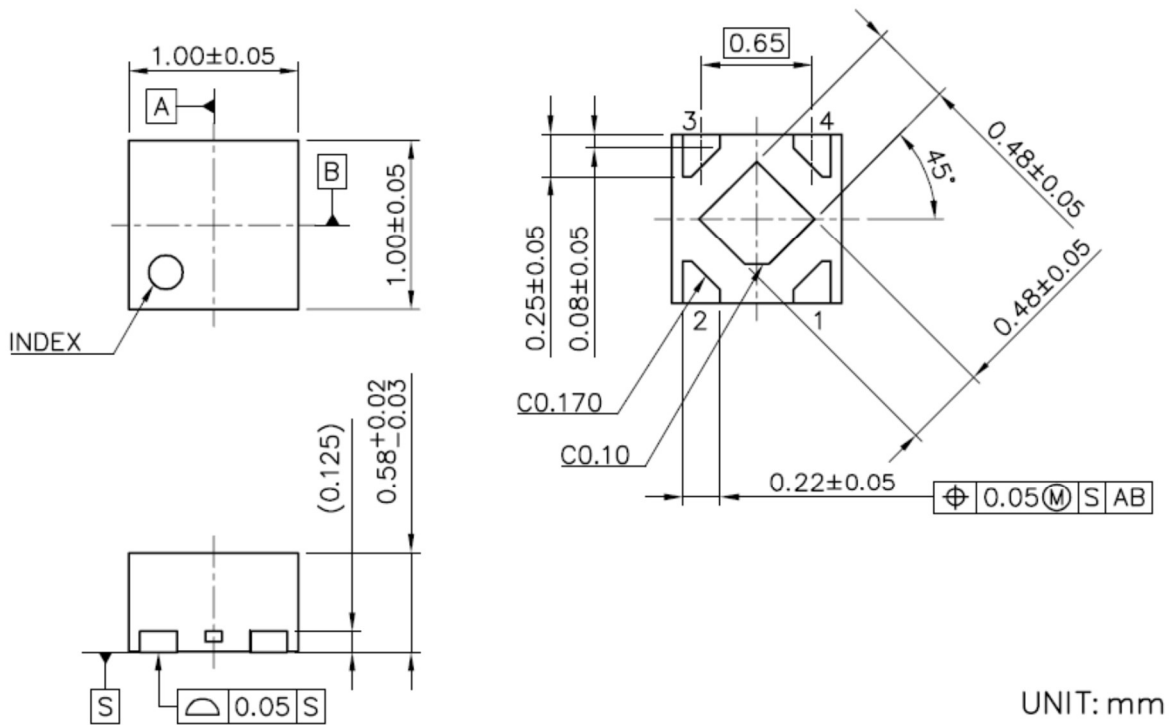

DFN (PLP) 1010-4B Package Dimensions

* The tab on the bottom of the package is a substrate potential (GND/V_{DD}). It is recommended that this tab be connected to the ground plane/V_{DD} pin on the board but it is possible to leave the tab floating.

- ①②: Product Code ... **Refer to the following table**
- ③④: Lot Number ... Alphanumeric Serial Number

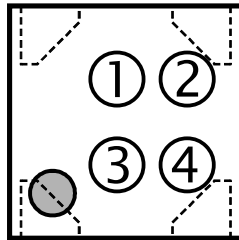

DFN(PLP)1010-4B Marking Specification

NOTICE

There can be variation in the marking when different AOI (Automated Optical Inspection) equipment is used. In the case of recognizing the marking characteristic with AOI, please contact our sales or our distributor before attempting to use AOI.

RP300K Marking List

Product Name	①②	Product Name	①②	Product Name	①②
RP300K11AA	EA	RP300K27AB	FH	RP300K30AC8	GR
RP300K11BA	EB	RP300K27BB	FJ	RP300K30BC8	GS
RP300K11DA	EC	RP300K27DB	FK	RP300K30DC8	GT
RP300K11AB	ED	RP300K27AC	FL	RP300K42AA	WD
RP300K11BB	EE	RP300K27BC	FM	RP300K42BA	WE
RP300K11DB	EF	RP300K27DC	FN	RP300K42DA	WF
RP300K11AC	EG	RP300K28AA	FP	RP300K42AB	WG
RP300K11BC	EH	RP300K28BA	FR	RP300K42BB	WH
RP300K11DC	EJ	RP300K28DA	FS	RP300K42DB	WJ
RP300K23AA2	EK	RP300K28AB	FT	RP300K42AC	WK
RP300K23BA2	EL	RP300K28BB	FU	RP300K42BC	WL
RP300K23DA2	EM	RP300K28DB	FV	RP300K42DC	WM
RP300K23AB2	EN	RP300K28AC	FW	RP300K43AA8	GU
RP300K23BB2	EP	RP300K28BC	FX	RP300K43BA8	GV
RP300K23DB2	ER	RP300K28DC	FY	RP300K43DA8	GW
RP300K23AC2	ES	RP300K29AA3	FZ	RP300K43AB8	GX
RP300K23BC2	ET	RP300K29BA3	GA	RP300K43BB8	GY
RP300K23DC2	EU	RP300K29DA3	GB	RP300K43DB8	GZ
RP300K26AA3	EV	RP300K29AB3	GC	RP300K43AC8	HA
RP300K26BA3	EW	RP300K29BB3	GD	RP300K43BC8	HB
RP300K26DA3	EX	RP300K29DB3	GE	RP300K43DC8	HC
RP300K26AB3	EY	RP300K29AC3	GF	RP300K46AA	HN
RP300K26BB3	EZ	RP300K29BC3	GG	RP300K46BA	HP
RP300K26DB3	FA	RP300K29DC3	GH	RP300K46DA	HR
RP300K26AC3	FB	RP300K30AA8	GJ	RP300K46AB	HS
RP300K26BC3	FC	RP300K30BA8	GK	RP300K46BB	HT
RP300K26DC3	FD	RP300K30DA8	GL	RP300K46DB	HU
RP300K27AA	FE	RP300K30AB8	GM	RP300K46AC	HV
RP300K27BA	FF	RP300K30BB8	GN	RP300K46BC	HW
RP300K27DA	FG	RP300K30DB8	GP	RP300K46DC	HX

The power dissipation of the package is dependent on PCB material, layout, and environmental conditions. The following measurement conditions are based on JEDEC STD. 51-7.

Measurement Conditions

Item	Measurement Conditions
Environment	Mounting on Board (Wind Velocity = 0 m/s)
Board Material	Glass Cloth Epoxy Plastic (Four-Layer Board)
Board Dimensions	76.2 mm × 114.3 mm × 0.8 mm
Copper Ratio	Outer Layer (First Layer): Less than 95% of 50 mm Square Inner Layers (Second and Third Layers): Approx. 100% of 50 mm Square Outer Layer (Fourth Layer): Approx. 100% of 50 mm Square
Through-holes	φ 0.3 mm × 7 pcs

Measurement Result

(Ta = 25°C, Tjmax = 125°C)

Item	Measurement Result
Power Dissipation	660 mW
Thermal Resistance (θ_{ja})	$\theta_{ja} = 150^\circ\text{C/W}$
Thermal Characterization Parameter (ψ_{jt})	$\psi_{jt} = 51^\circ\text{C/W}$

θ_{ja} : Junction-to-Ambient Thermal Resistance

ψ_{jt} : Junction-to-Top Thermal Characterization Parameter

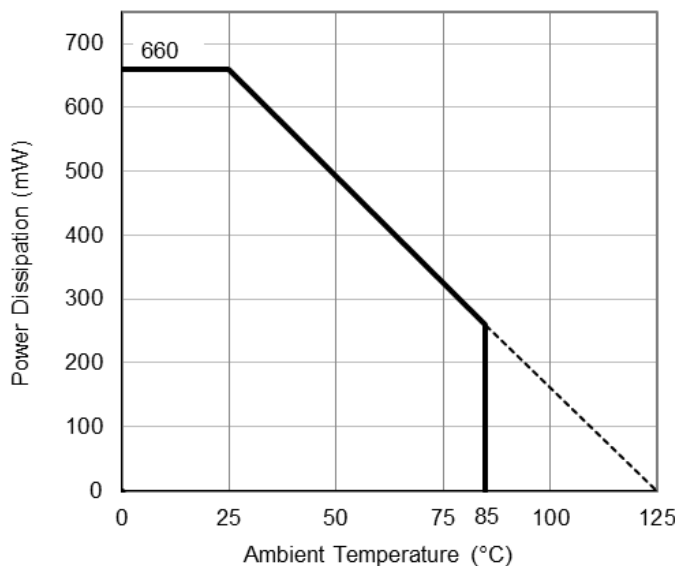

Power Dissipation vs. Ambient Temperature

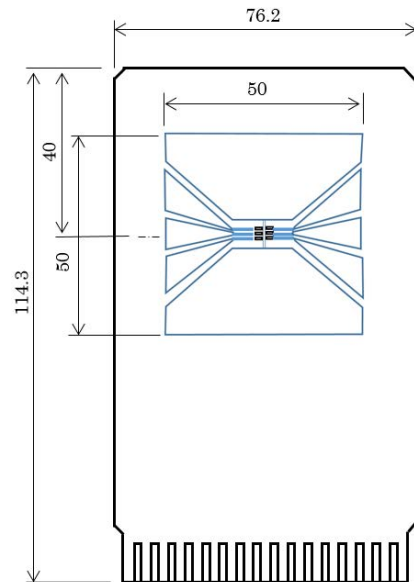

Measurement Board Pattern

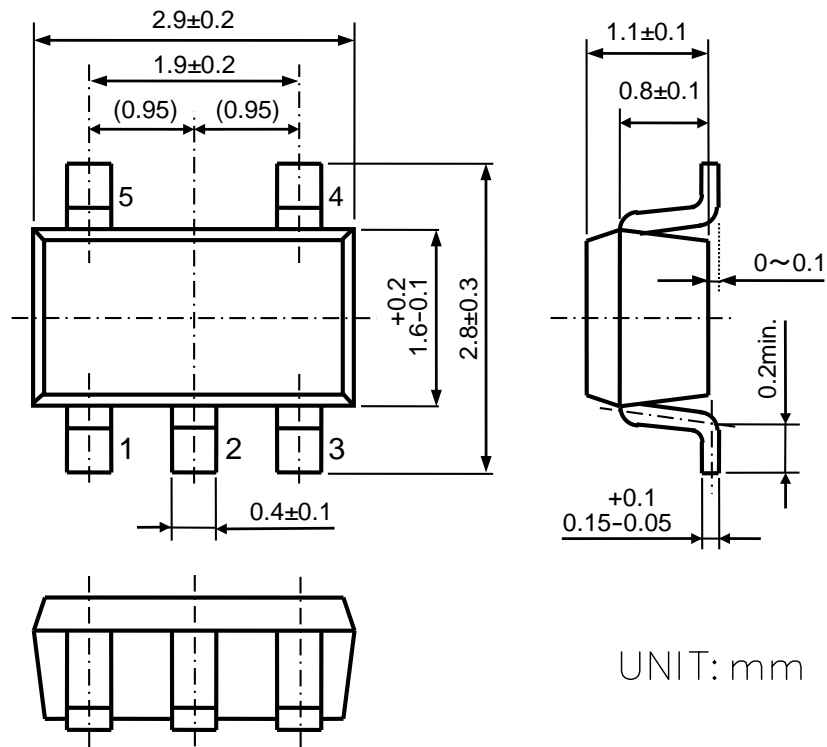

UNIT: mm

SOT-23-5 Package Dimensions

①②③: Product Code ... **Refer to the following table**
④⑤: Lot Number ... Alphanumeric Serial Number

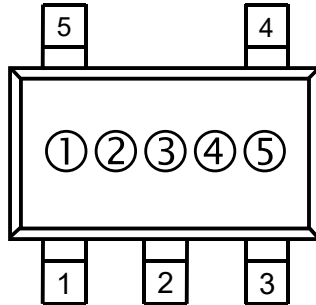

SOT-23-5 Marking Specification

NOTICE

There can be variation in the marking when different AOI (Automated Optical Inspection) equipment is used. In the case of recognizing the marking characteristic with AOI, please contact our sales or our distributor before attempting to use AOI.

MARKING SPECIFICATION**RP300N**

MK-RP300N-JE-C

RP300N Marking List

Product Name	①②③	Product Name	①②③	Product Name	①②③
RP300N11AA	X01	RP300N27AB	X31	RP300N30AC8	X61
RP300N11BA	X02	RP300N27BB	X32	RP300N30BC8	X62
RP300N11DA	X03	RP300N27DB	X33	RP300N30DC8	X63
RP300N11AB	X04	RP300N27AC	X34	RP300N42AA	G46
RP300N11BB	X05	RP300N27BC	X35	RP300N42BA	G47
RP300N11DB	X06	RP300N27DC	X36	RP300N42DA	G48
RP300N11AC	X07	RP300N28AA	X37	RP300N42AB	G49
RP300N11BC	X08	RP300N28BA	X38	RP300N42BB	G50
RP300N11DC	X09	RP300N28DA	X39	RP300N42DB	G51
RP300N23AA2	X10	RP300N28AB	X40	RP300N42AC	G52
RP300N23BA2	X11	RP300N28BB	X41	RP300N42BC	G53
RP300N23DA2	X12	RP300N28DB	X42	RP300N42DC	G54
RP300N23AB2	X13	RP300N28AC	X43	RP300N43AA8	X64
RP300N23BB2	X14	RP300N28BC	X44	RP300N43BA8	X65
RP300N23DB2	X15	RP300N28DC	X45	RP300N43DA8	X66
RP300N23AC2	X16	RP300N29AA3	X46	RP300N43AB8	X67
RP300N23BC2	X17	RP300N29BA3	X47	RP300N43BB8	X68
RP300N23DC2	X18	RP300N29DA3	X48	RP300N43DB8	X69
RP300N26AA3	X19	RP300N29AB3	X49	RP300N43AC8	X70
RP300N26BA3	X20	RP300N29BB3	X50	RP300N43BC8	X71
RP300N26DA3	X21	RP300N29DB3	X51	RP300N43DC8	X72
RP300N26AB3	X22	RP300N29AC3	X52	RP300N46AA	X82
RP300N26BB3	X23	RP300N29BC3	X53	RP300N46BA	X83
RP300N26DB3	X24	RP300N29DC3	X54	RP300N46DA	X84
RP300N26AC3	X25	RP300N30AA8	X55	RP300N46AB	X85
RP300N26BC3	X26	RP300N30BA8	X56	RP300N46BB	X86
RP300N26DC3	X27	RP300N30DA8	X57	RP300N46DB	X87
RP300N27AA	X28	RP300N30AB8	X58	RP300N46AC	X88
RP300N27BA	X29	RP300N30BB8	X59	RP300N46BC	X89
RP300N27DA	X30	RP300N30DB8	X60	RP300N46DC	X90

1. The products and the product specifications described in this document are subject to change or discontinuation of production without notice for reasons such as improvement. Therefore, before deciding to use the products, please refer to our sales representatives for the latest information thereon.
2. The materials in this document may not be copied or otherwise reproduced in whole or in part without the prior written consent of us.
3. This product and any technical information relating thereto are subject to complementary export controls (so-called KNOW controls) under the Foreign Exchange and Foreign Trade Law, and related politics ministerial ordinance of the law. (Note that the complementary export controls are inapplicable to any application-specific products, except rockets and pilotless aircraft, that are insusceptible to design or program changes.) Accordingly, when exporting or carrying abroad this product, follow the Foreign Exchange and Foreign Trade Control Law and its related regulations with respect to the complementary export controls.
4. The technical information described in this document shows typical characteristics and example application circuits for the products. The release of such information is not to be construed as a warranty of or a grant of license under our or any third party's intellectual property rights or any other rights.
5. The products listed in this document are intended and designed for use as general electronic components in standard applications (office equipment, telecommunication equipment, measuring instruments, consumer electronic products, amusement equipment etc.). Those customers intending to use a product in an application requiring extreme quality and reliability, for example, in a highly specific application where the failure or misoperation of the product could result in human injury or death should first contact us.
 - Aerospace Equipment
 - Equipment Used in the Deep Sea
 - Power Generator Control Equipment (nuclear, steam, hydraulic, etc.)
 - Life Maintenance Medical Equipment
 - Fire Alarms / Intruder Detectors
 - Vehicle Control Equipment (automotive, airplane, railroad, ship, etc.)
 - Various Safety Devices
 - Traffic control system
 - Combustion equipment

In case your company desires to use this product for any applications other than general electronic equipment mentioned above, make sure to contact our company in advance. Note that the important requirements mentioned in this section are not applicable to cases where operation requirements such as application conditions are confirmed by our company in writing after consultation with your company.

6. We are making our continuous effort to improve the quality and reliability of our products, but semiconductor products are likely to fail with certain probability. In order to prevent any injury to persons or damages to property resulting from such failure, customers should be careful enough to incorporate safety measures in their design, such as redundancy feature, fire containment feature and fail-safe feature. We do not assume any liability or responsibility for any loss or damage arising from misuse or inappropriate use of the products.
7. The products have been designed and tested to function within controlled environmental conditions. Do not use products under conditions that deviate from methods or applications specified in this datasheet. Failure to employ the products in the proper applications can lead to deterioration, destruction or failure of the products. We shall not be responsible for any bodily injury, fires or accident, property damage or any consequential damages resulting from misuse or misapplication of the products.
8. **Quality Warranty**
 - 8-1. **Quality Warranty Period**

In the case of a product purchased through an authorized distributor or directly from us, the warranty period for this product shall be one (1) year after delivery to your company. For defective products that occurred during this period, we will take the quality warranty measures described in section 8-2. However, if there is an agreement on the warranty period in the basic transaction agreement, quality assurance agreement, delivery specifications, etc., it shall be followed.
 - 8-2. **Quality Warranty Remedies**

When it has been proved defective due to manufacturing factors as a result of defect analysis by us, we will either deliver a substitute for the defective product or refund the purchase price of the defective product.
Note that such delivery or refund is sole and exclusive remedies to your company for the defective product.
 - 8-3. **Remedies after Quality Warranty Period**

With respect to any defect of this product found after the quality warranty period, the defect will be analyzed by us. On the basis of the defect analysis results, the scope and amounts of damage shall be determined by mutual agreement of both parties. Then we will deal with upper limit in Section 8-2. This provision is not intended to limit any legal rights of your company.
9. Anti-radiation design is not implemented in the products described in this document.
10. The X-ray exposure can influence functions and characteristics of the products. Confirm the product functions and characteristics in the evaluation stage.
11. WLCSP products should be used in light shielded environments. The light exposure can influence functions and characteristics of the products under operation or storage.
12. Warning for handling Gallium and Arsenic (GaAs) products (Applying to GaAs MMIC, Photo Reflector). These products use Gallium (Ga) and Arsenic (As) which are specified as poisonous chemicals by law. For the prevention of a hazard, do not burn, destroy, or process chemically to make them as gas or power. When the product is disposed of, please follow the related regulation and do not mix this with general industrial waste or household waste.
13. Please contact our sales representatives should you have any questions or comments concerning the products or the technical information.



Nisshinbo Micro Devices Inc.

Official website

<https://www.nisshinbo-microdevices.co.jp/en/>

Purchase information

<https://www.nisshinbo-microdevices.co.jp/en/buy/>