

RECOMMENDED MOUNTING HOLES

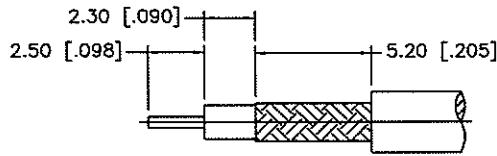

RECOMMENDED CABLE STRIPPING DIM'S

REV.	DATE	ECR NO.	DESCRIPTION
A	04/27/99	-	MODIFY FERRULE/ ADD NOTES 1 AND 2
B	09/29/04	-	MODIFY FERRULE AND CRIMP NOTES
C	09/17/08	-	ADD FLAT TO BODY/ REVISE FERRULE DIMENSIONS/ ADD NOTE 3 REVISE CABLE DESCRIPTION TO 316/U DB CABLE

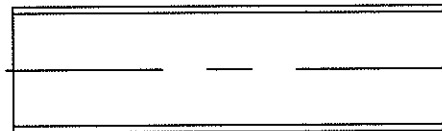
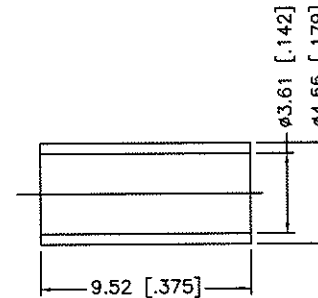
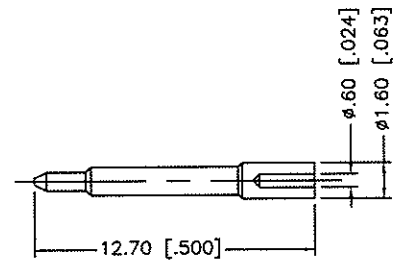
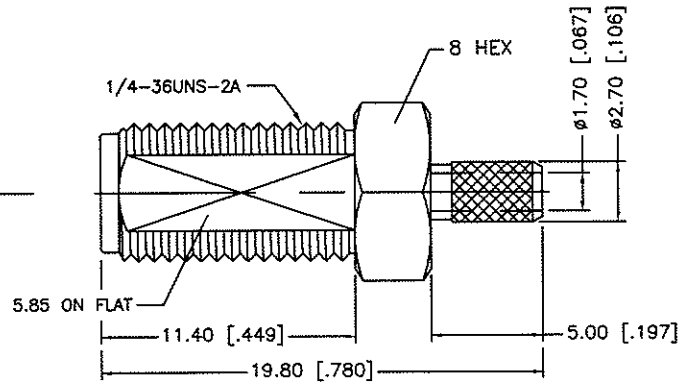
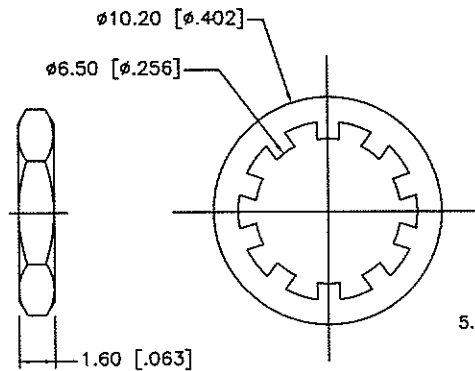

NOTE:

1. CRIMPED FERRULE HEX CRIMP SIZE .151" [3.83]
2. CONTACT PIN TO SOLDER.
3. MAX. PANEL THICKNESS OF 3.20 [1.26"]

8				
7	HEAT SHRINK TUBING	BLK	A/R	
6	FERRULE	COPPER	GOLD	1
5	HEX NUT	BRASS	GOLD	1
4	LOCK WASHER	BRASS	GOLD	1
3	CONTACT PIN	BRASS	GOLD	1
2	INSULATOR	PTFE	NATURAL	1
1	BODY	BRASS	GOLD	1
DESCRIPTION	MATERIAL	FINISH	QTY	

UNLESS OTHERWISE SPECIFIED DIMENSIONS ARE IN MILLIMETERS. DIMENSIONS IN [] ARE IN INCHES AND FOR CUSTOMER REFERENCE ONLY.

UNLESS OTHERWISE SPECIFIED TOLERANCES FOR MILLIMETERS ARE:
 0.5 - 8mm ± 0.20mm
 8 - 30mm ± 0.40mm
 30 - 120mm ± 0.50mm

UNLESS OTHERWISE SPECIFIED TOLERANCES FOR INCHES ARE:
 .020 - .315 = ± 0.007"
 .315 - 1.180 = ± 0.015"
 1.180 - 4.724 = ± 0.020"

DO NOT SCALE DRAWING

APPROVALS		DATE
DRAWN	GRS	09/17/08
CHECKED		
ISSUED		
SHEET	1 OF 1	
CAD FILE	C:/132/132176RP.DWG	

Amphenol Connex

PART DESCRIPTION

SMA REVERSE POLARITY BULKHEAD
CRIMP JACK (FOR 316/U DOUBLE BRAID CABLE)

PART NO.

132176RP

DWG. NO.

132176RP.DWG

REV. NC

SIZE A

SCALE NA

9/16/08

REVISIONS	
ISS	ZONE
	DESCRIPTION PER REQUEST DATE

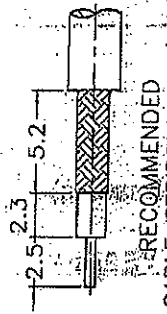
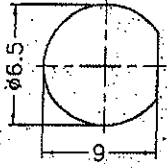

RECOMMENDED MOUNTING HOLE (建議安裝孔)

RECOMMENDED CABLE STRIPPING DIM'S (建議剝線尺寸)

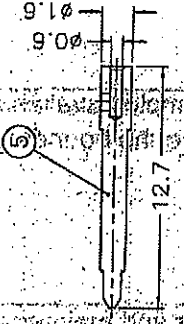
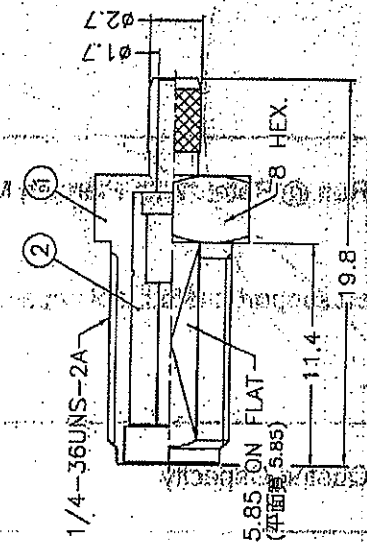
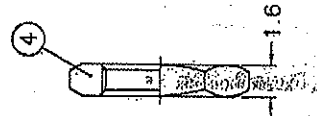
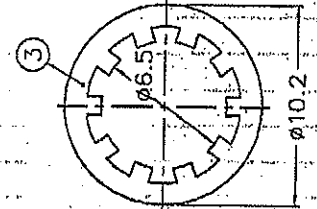

- NOTES: FINISH (PLATING THICKNESS IN MICRO-INCHES)
- BRASS PER QQ-B-626
 - BRASS PER QQ-B-613
 - GOLD PL. 3 MIN. THICK, OVER NICKEL PL. 100 MIN. THICK OVER COPPER STRIKE
 - GOLD PL. 50 MIN. THICK OVER NICKEL PL. 100 MIN. THICK OVER COPPER STRIKE
 - TEFLON MIL-P-19468

- CRIMPED FERRULE
- HEX CRIMP SIZE .151"
- CONTACT PIN TO SOLDER
- MAX. PANEL THICKNESS = 3.2mm

NO.	DESCRIPTION	MATERIAL	FINISH	QTY	DRAWING NO.	SCALE	ISSUE
7	HEAT SHRINK TUBING	BLACK		1	HT-56/5X193	3/1	1
6	FERRULE	COPPER	NOTE 3	1	3A-1357-B	3/1	1
5	CONTACT PIN	NOTE 1	NOTE 4	1	RSMA6111A2-3	3/1	1
4	HEX NUT	NOTE 1	NOTE 3	1	HNB-5/4-36X16	3/1	1
3	LOCK WASHER	NOTE 2	NOTE 3	1	LW-102/65X05	3/1	1
2	INSULATOR	NOTE 5	NATURAL	1	SMAT000-2T-50	3/1	1
1	BODY	NOTE 1	NOTE 3	1	SMAG411A2-1	3/1	1

PART NO.	DATE
138176RP	11-25-02
APPROVED	DATE
CHECKED	DATE
DRAWN	DATE
KEN	11-25-02

Amphenol
 Danbury, CT, USA - London, London - Shenzhen, China
 TITLE SMA REVERSE POLARITY BULKHEAD CRIMP JACK (FOR RC-3164/4)
 DRAWING NO. RSMA6411A2-004-3GT50G-50
 ITEM NO. 616411AAK35CA5F

NO.	DESCRIPTION	MATERIAL	FINISH	QTY	DRAWING NO.	SCALE	ISSUE
1	DESCRIPTION			1	FILE NO. F:\DWG\RSMA\6411A2\004\50\3GT50G	3/1	1

