

- 1
- 2
- 3
- 4
- 5
- 6
- 7
- 8
- 9
- 10
- 11
- 12
- 13
- 14
- 15
- 16
- 17
- 18

CAM LEVER BODY

Glass-fibre reinforced polyamide based (PA) technopolymer, black colour, matte finish.

ROTATING PIN

Glossy zinc-plated steel or AISI 303 stainless steel, with threaded hole or threaded stud.

CONNECTION AND RETENTION ELEMENT BETWEEN THE LEVER AND THE CAM SLIDING BASE

Polyamide based (PA) technopolymer, black colour.

CAM SLIDING BASE

Polyamide-based SUPER-technopolymer (PA), black colour.

ADJUSTABLE KNURLED RING-NUT

Polyamide-based SUPER-technopolymer (PA), black colour.

STANDARD EXECUTIONS

- **LAC-B:** positioning without adjustable ring-nut, rotating pin with zinc-plated steel threaded hole.
- **LAC-SST:** positioning without adjustable ring-nut, rotating pin with AISI 303 stainless steel threaded hole.
- **LAC-p:** positioning without adjustable ring-nut, rotating pin with zinc-plated steel threaded stud, chamfered flat end UNI 947: ISO 4753 Technical data on page A-11).
- **LAC-SST-p:** positioning without adjustable ring-nut, rotating pin with AISI 303 stainless steel threaded stud, chamfered flat end UNI 947: ISO 4753 Technical data on page A-11).
- **LAC-B-R:** positioning with adjustable ring-nut, rotating pin with zinc-plated steel threaded hole.
- **LAC-SST-R:** positioning with adjustable ring-nut, rotating pin with AISI 303 stainless steel threaded hole.
- **LAC-p-R:** positioning with adjustable ring-nut, rotating pin with threaded stud in zinc-plated steel, chamfered flat end UNI 947: ISO 4753 (see Technical data on page A-11).
- **LAC-SST-p-R:** positioning with adjustable ring-nut, rotating pin with threaded stud in AISI 303 stainless steel, chamfered flat end UNI 947: ISO 4753 Technical data on page A-11).

FEATURES AND APPLICATIONS

Cam lever is a device which allows a quick and secure clamping. The LAC-R model with adjustable ring-nut (ELESA patent) offers quick and secure clamping. The knurled ring-nut on the base allows to adjust the clamping force applied while locking the lever in the desired position.

SPECIAL EXECUTIONS ON REQUEST

Cam clamps with connection element, not drilled for a better cleaning (for sufficient quantities).

RECOMMENDATIONS FOR ASSEMBLY

LAC-B, LAC-SST, LAC-B-R and LAC-SST-R with threaded hole. The screw where the cam lever is mounted must protrude from the assembly surface by a maximum length of h1 max from the end-stop as shown in table and Fig.1. The user will notice the h1 max value is reached as the screw rests on the end-stop in the connecting element.

INSTRUCTIONS FOR CLAMPING AND ADJUSTMENT

- LAC: lift and rotate the lever clockwise until it stops, then, to complete clamping, lower the lever whose fulcrum is an eccentric cam which controls the base by rotating.
 - LAC-R: rotate the lever clockwise until it stops.
- Fine adjustment: rotate clockwise or anti-clockwise the knurled adjustable ring-nut to calibrate the clamping force and put the lever in the desired position. The ring-nut is marked with minimum and maximum adjustment values: half a turn is enough for adjustment.
- Clamping: lower the lever whose fulcrum is an eccentric cam which controls the adjusting base by rotating.



Clamping

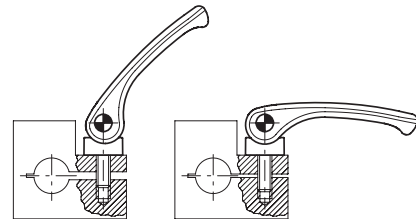

LAC

LAC-R

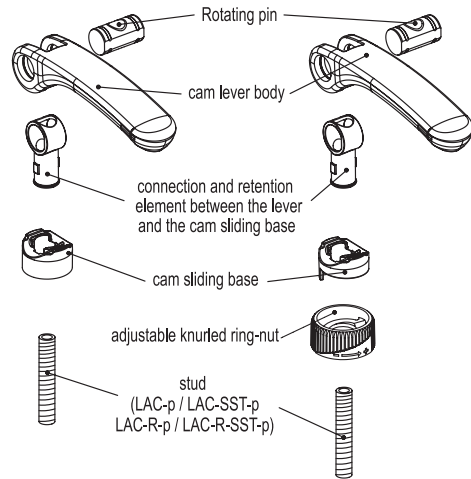

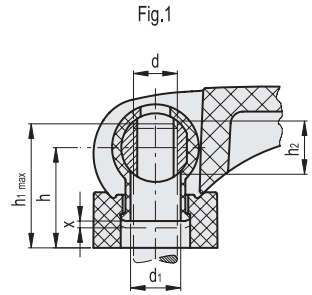
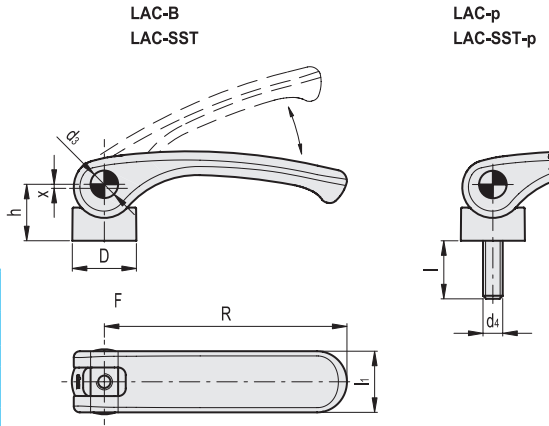

Conversion Table 1 mm = 0.039 inch	
R	
mm	inch
44	1.73
63	2.48
79	3.11

LAC-B

Code	Description	R	d	D	h	h1 max	h2	d1	d3	l1	x	Fmax* [N]	⚖️
33321	LAC.44-B-M5	44	M5	17.5	18	20.5	5.5	6.1	9	18	0.5	3500	19
33422	LAC.44-B-M6	44	M6	17.5	18	20.5	5.5	6.1	9	18	0.5	3500	19
33483	LAC.63-B-M5	63	M5	17.5	18	20.5	5.5	6.1	9	18	0.75	4000	23
33482	LAC.63-B-M6	63	M6	17.5	18	20.5	5.5	6.1	9	18	0.75	4000	23
33561	LAC.80-B-M6	79	M6	20	21	25.5	7	8.1	11	20	1	7000	32
33562	LAC.80-B-M8	79	M8	20	21	25.5	7	8.1	11	20	1	7000	32

LAC-SST

Code	Description	⚖️
33323	LAC.44-SST-M5	19
33423	LAC.44-SST-M6	19
33486	LAC.63-SST-M5	23
33487	LAC.63-SST-M6	23
33566	LAC.80-SST-M6	32
33567	LAC.80-SST-M8	32

INOX STAINLESS STEEL
METRIC

LAC-p

Code	Description	R	d4	D	h	d3	l	l1	x	Fmax* [N]	⚖️
33331	LAC.44-p-M5x20	44	M5	17.5	18	9	20	18	0.5	3500	29
33332	LAC.44-p-M5x25	44	M5	17.5	18	9	25	18	0.5	3500	29
33333	LAC.44-p-M5x30	44	M5	17.5	18	9	30	18	0.5	3500	29
33334	LAC.44-p-M5x40	44	M5	17.5	18	9	40	18	0.5	3500	29
33335	LAC.44-p-M5x50	44	M5	17.5	18	9	50	18	0.5	3500	29
33341	LAC.44-p-M6x20	44	M6	17.5	18	9	20	18	0.5	3500	29
33424	LAC.44-p-M6x25	44	M6	17.5	18	9	25	18	0.5	3500	29
33342	LAC.44-p-M6x30	44	M6	17.5	18	9	30	18	0.5	3500	29
33343	LAC.44-p-M6x40	44	M6	17.5	18	9	40	18	0.5	3500	29
33426	LAC.44-p-M6x50	44	M6	17.5	18	9	50	18	0.5	3500	38
33652	LAC.63-p-M5x20	63	M5	17.5	18	9	20	18	0.75	4000	33
33653	LAC.63-p-M5x25	63	M5	17.5	18	9	25	18	0.75	4000	33
33654	LAC.63-p-M5x30	63	M5	17.5	18	9	30	18	0.75	4000	33
33655	LAC.63-p-M5x40	63	M5	17.5	18	9	40	18	0.75	4000	33
33656	LAC.63-p-M5x50	63	M5	17.5	18	9	50	18	0.75	4000	33
33493	LAC.63-p-M6x20	63	M6	17.5	18	9	20	18	0.75	4000	33
33492	LAC.63-p-M6x25	63	M6	17.5	18	9	25	18	0.75	4000	33
33494	LAC.63-p-M6x30	63	M6	17.5	18	9	30	18	0.75	4000	33
33495	LAC.63-p-M6x40	63	M6	17.5	18	9	40	18	0.75	4000	33
33496	LAC.63-p-M6x50	63	M6	17.5	18	9	50	18	0.75	4000	42
33572	LAC.80-p-M6x25	79	M6	20	21	11	25	20	1	7000	46
33573	LAC.80-p-M6x30	79	M6	20	21	11	30	20	1	7000	46
33574	LAC.80-p-M6x40	79	M6	20	21	11	40	20	1	7000	46
33576	LAC.80-p-M6x50	79	M6	20	21	11	50	20	1	7000	46
33582	LAC.80-p-M8x25	79	M8	20	21	11	25	20	1	7000	46
33583	LAC.80-p-M8x30	79	M8	20	21	11	30	20	1	7000	46
33584	LAC.80-p-M8x40	79	M8	20	21	11	40	20	1	7000	46
33586	LAC.80-p-M8x50	79	M8	20	21	11	50	20	1	7000	55

LAC-SST-p

Code	Description	⚖️
33351	LAC.44-SST-p-M5x20	29
33352	LAC.44-SST-p-M5x25	29
33353	LAC.44-SST-p-M5x30	29
33354	LAC.44-SST-p-M5x40	29
33355	LAC.44-SST-p-M5x50	29
33361	LAC.44-SST-p-M6x20	29
33427	LAC.44-SST-p-M6x25	29
33362	LAC.44-SST-p-M6x30	29
33363	LAC.44-SST-p-M6x40	29
33429	LAC.44-SST-p-M6x50	38
33502	LAC.63-SST-p-M5x20	33
33503	LAC.63-SST-p-M5x25	33
33504	LAC.63-SST-p-M5x30	33
33505	LAC.63-SST-p-M5x40	33
33506	LAC.63-SST-p-M5x50	33
33498	LAC.63-SST-p-M6x20	33
33497	LAC.63-SST-p-M6x25	33
33499	LAC.63-SST-p-M6x30	33
33500	LAC.63-SST-p-M6x40	33
33501	LAC.63-SST-p-M6x50	42
33672	LAC.80-SST-p-M6x25	46
33673	LAC.80-SST-p-M6x30	46
33674	LAC.80-SST-p-M6x40	46
33676	LAC.80-SST-p-M6x50	46
33587	LAC.80-SST-p-M8x25	46
33589	LAC.80-SST-p-M8x30	46
33590	LAC.80-SST-p-M8x40	46
33591	LAC.80-SST-p-M8x50	55

INOX STAINLESS STEEL
METRIC

* Maximum clamping force.

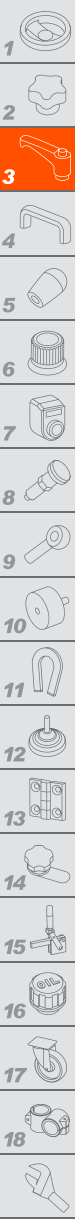

- 1
- 2
- 3
- 4
- 5
- 6
- 7
- 8
- 9
- 10
- 11
- 12
- 13
- 14
- 15
- 16
- 17
- 18

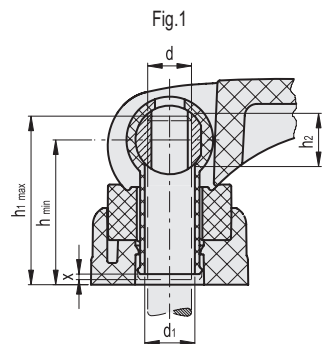
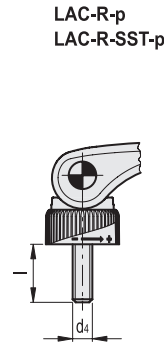
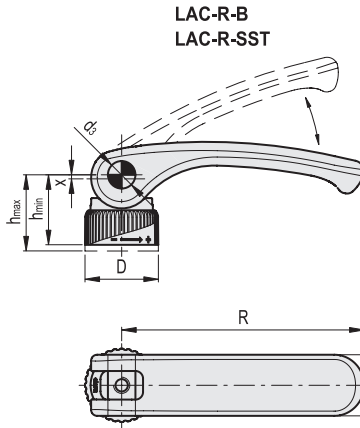

INOX STAINLESS STEEL
METRIC

Conversion Table
1 mm = 0.039 inch

mm	inch
44	1.73
63	2.48
79	3.11

LAC-B-R

Code	Description	R	d	D	hmin	hmax	h1 max	h2	d1	d3	l1	x	Fmax* [N]	⚖️
33221	LAC.44-B-M5-R	44	M5	22	22.5	24	26.5	5.5	6.1	9	18	0.5	3500	21
33412	LAC.44-B-M6-R	44	M6	22	22.5	24	26.5	5.5	6.1	9	18	0.5	3500	21
33461	LAC.63-B-M5-R	63	M5	22	22.5	24	26.5	5.5	6.1	9	18	0.75	4000	25
33462	LAC.63-B-M6-R	63	M6	22	22.5	24	26.5	5.5	6.1	9	18	0.75	4000	25
33511	LAC.80-B-M6-R	79	M6	25	26.5	28	32.5	7	8.1	11	20	1	7000	39
33512	LAC.80-B-M8-R	79	M8	25	26.5	28	32.5	7	8.1	11	20	1	7000	39

LAC-SST-R

Code	Description	⚖️
33223	LAC.44-SST-M5-R	21
33413	LAC.44-SST-M6-R	21
33463	LAC.63-SST-M5-R	25
33467	LAC.63-SST-M6-R	25
33516	LAC.80-SST-M6-R	39
33517	LAC.80-SST-M8-R	39

INOX STAINLESS STEEL
METRIC

LAC-p-R

Code	Description	R	d4	D	hmin	hmax	d3	l	l1	x	Fmax* [N]	⚖️
33231	LAC.44-p-M5x20-R	44	M5	22	22.5	24	9	20	18	0.5	3500	31
33232	LAC.44-p-M5x25-R	44	M5	22	22.5	24	9	25	18	0.5	3500	31
33233	LAC.44-p-M5x30-R	44	M5	22	22.5	24	9	30	18	0.5	3500	31
33234	LAC.44-p-M5x40-R	44	M5	22	22.5	24	9	40	18	0.5	3500	31
33235	LAC.44-p-M5x50-R	44	M5	22	22.5	24	9	50	18	0.5	3500	31
33241	LAC.44-p-M6x20-R	44	M6	22	22.5	24	9	20	18	0.5	3500	31
33414	LAC.44-p-M6x25-R	44	M6	22	22.5	24	9	25	18	0.5	3500	31
33242	LAC.44-p-M6x30-R	44	M6	22	22.5	24	9	30	18	0.5	3500	31
33243	LAC.44-p-M6x40-R	44	M6	22	22.5	24	9	40	18	0.5	3500	31
33416	LAC.44-p-M6x50-R	44	M6	22	22.5	24	9	50	18	0.5	3500	40
33465	LAC.63-p-M5x20-R	63	M5	22	22.5	24	9	20	18	0.75	4000	35
33466	LAC.63-p-M5x25-R	63	M5	22	22.5	24	9	25	18	0.75	4000	35
33468	LAC.63-p-M5x30-R	63	M5	22	22.5	24	9	30	18	0.75	4000	35
33469	LAC.63-p-M5x40-R	63	M5	22	22.5	24	9	40	18	0.75	4000	35
33470	LAC.63-p-M5x50-R	63	M5	22	22.5	24	9	50	18	0.75	4000	35
33471	LAC.63-p-M6x20-R	63	M6	22	22.5	24	9	20	18	0.75	4000	35
33472	LAC.63-p-M6x25-R	63	M6	22	22.5	24	9	25	18	0.75	4000	35
33473	LAC.63-p-M6x30-R	63	M6	22	22.5	24	9	30	18	0.75	4000	35
33474	LAC.63-p-M6x40-R	63	M6	22	22.5	24	9	40	18	0.75	4000	35
33476	LAC.63-p-M6x50-R	63	M6	22	22.5	24	9	50	18	0.75	4000	44
33522	LAC.80-p-M6x25-R	79	M6	25	26.5	28	11	25	20	1	7000	53
33523	LAC.80-p-M6x30-R	79	M6	25	26.5	28	11	30	20	1	7000	53
33524	LAC.80-p-M6x40-R	79	M6	25	26.5	28	11	40	20	1	7000	53
33526	LAC.80-p-M6x50-R	79	M6	25	26.5	28	11	50	20	1	7000	53
33532	LAC.80-p-M8x25-R	79	M8	25	26.5	28	11	25	20	1	7000	53
33533	LAC.80-p-M8x30-R	79	M8	25	26.5	28	11	30	20	1	7000	53
33534	LAC.80-p-M8x40-R	79	M8	25	26.5	28	11	40	20	1	7000	53
33536	LAC.80-p-M8x50-R	79	M8	25	26.5	28	11	50	20	1	7000	62

LAC-SST-p-R

Code	Description	⚖️
33251	LAC.44-SST-p-M5x20-R	31
33252	LAC.44-SST-p-M5x25-R	31
33253	LAC.44-SST-p-M5x30-R	31
33254	LAC.44-SST-p-M5x40-R	31
33255	LAC.44-SST-p-M5x50-R	31
33261	LAC.44-SST-p-M6x20-R	31
33417	LAC.44-SST-p-M6x25-R	31
33262	LAC.44-SST-p-M6x30-R	31
33263	LAC.44-SST-p-M6x40-R	31
33419	LAC.44-SST-p-M6x50-R	40
33642	LAC.63-SST-p-M5x20-R	35
33643	LAC.63-SST-p-M5x25-R	35
33644	LAC.63-SST-p-M5x30-R	35
33645	LAC.63-SST-p-M5x40-R	35
33646	LAC.63-SST-p-M5x50-R	35
33478	LAC.63-SST-p-M6x20-R	35
33477	LAC.63-SST-p-M6x25-R	35
33479	LAC.63-SST-p-M6x30-R	35
33480	LAC.63-SST-p-M6x40-R	35
33481	LAC.63-SST-p-M6x50-R	44
33662	LAC.80-SST-p-M6x25-R	53
33663	LAC.80-SST-p-M6x30-R	53
33664	LAC.80-SST-p-M6x40-R	53
33666	LAC.80-SST-p-M6x50-R	53
33537	LAC.80-SST-p-M8x25-R	53
33539	LAC.80-SST-p-M8x30-R	53
33540	LAC.80-SST-p-M8x40-R	53
33541	LAC.80-SST-p-M8x50-R	62

Clamping handles

* Maximum clamping force.