

- NOTES
1. MATERIAL : BRASS , 0.5mm THICKNESS
 2. FINISH : 35750-1000 (UNPLATED)
35750-1010 (PRE-PLATED TIN)
(1.0 MICROMETER MIN. TIN OVER 0.3MICROMETER MIN. COPPER)
35723-0804 (POST TIN PLATED, 1.0 MIROMETER MIN.)
 3. RECOMMENDED LENGTH OF WIRE STRIP IS 4.8-5.4mm.
 4. APPLICABLE WIRE : AWG #18-#14 (0.75-2.08mm²)
INSULATION DIA. : Ø3.2mm MAX.

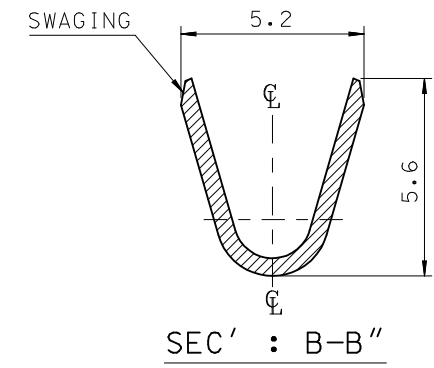
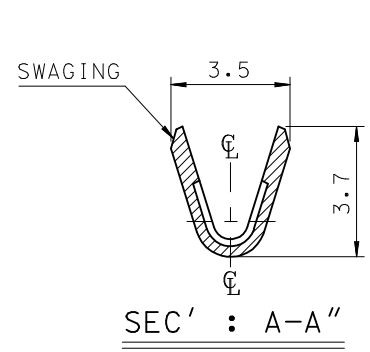
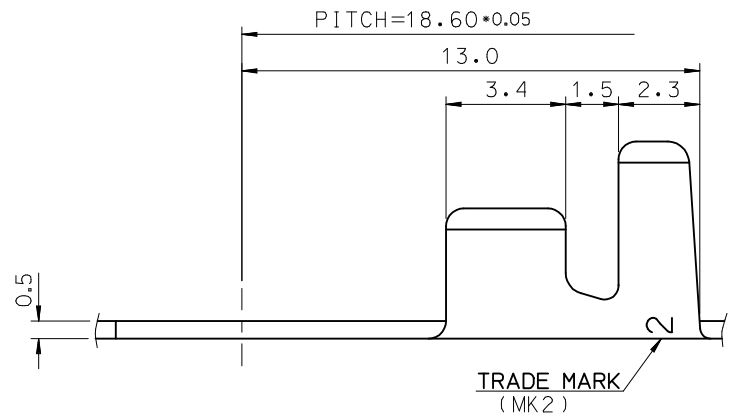

| | | | | | | | | | |
|---|-------------------------------|---------------------------------------|------------------------------|----------------------------|---|---------------------------------|------------------------|------------------------|--|
| REVISED EC NO: KOR2013-0049 DRWN: JSSHIN 2012/12/03 CHKD: SHCHU 2012/12/03 APPR: YSKIM02 2012/12/13 | QUALITY SYMBOLS ▽=0 ◻=0 | GENERAL TOLERANCES (UNLESS SPECIFIED) | | DIMENSION STYLE MM ONLY | | SCALE 4:1 | DESIGN UNITS METRIC | THIRD ANGLE PROJECTION | |
| | | 4 PLACES ± --- ± --- | 3 PLACES ± --- ± --- | DRAWN BY JS. JANG | DATE 1997/02/04 | TITLE 4.3 DIA. RING TERMINAL | | | |
| | | 2 PLACES ± 0.20 ± --- | 1 PLACE ± 0.30 ± --- | CHECKED BY BK. CHOI | DATE 1997/02/04 | molex | | | |
| | | 0 PLACE ± --- ± --- | ANGULAR ± 1 ° | APPROVED BY CW. LEE | DATE 1997/02/04 | | | | |
| DRAFT WHERE APPLICABLE MUST REMAIN WITHIN DIMENSIONS | SEE NOTES | MATERIAL NO. | DOCUMENT NO. SD-35750-001 | SHEET NO. 1 OF 1 | THIS DRAWING CONTAINS INFORMATION THAT IS PROPRIETARY TO MOLEX INCORPORATED AND SHOULD NOT BE USED WITHOUT WRITTEN PERMISSION | | | | |