

General Description

The MAX98358 development board (DEV board) is a fully assembled and tested PCB that evaluates the MAX98358 PDM digital input Class D power amplifier. The MAX98358 evaluation system (EV SYS) operates from a single 2.5V to 5.5V DC power supply and is capable of delivering 3.2W into a 4Ω load. The device outputs can be connected directly to a speaker load for filterless applications. However, a filter can be added to ease evaluation.

The EV SYS includes the DEV board, PDM Generator board (PDM GEN) and the Maxim Audio Interface board (AUDINT board). The AUDINT board provides an easy-to-use USB audio to I²S converter. The I²S data is fed into the PDM generator board that uses an FPGA to convert the I²S data stream into a PDM data stream. This allows for any computer to become a digital audio source that can be used to evaluate the device. The AUDINT board can also be used to power the part.

Features

- 2.5V to 5.5V Single-Supply Operation
- Only a Single External Component (VDD Capacitor) Required in Many Applications
- PDM Digital Input
- Five Selectable Gains (3dB, 6dB, 9dB, 12dB, and 15dB)
- Audio Channel Select (Left, Right, Mono Mix)
- Filterless Operation
- Optional Class D Output Filters for Ease of Evaluation
- Proven PCB Layout
- Fully Assembled and Tested

Ordering Information appears at end of data sheet.

Simplified Block Diagram

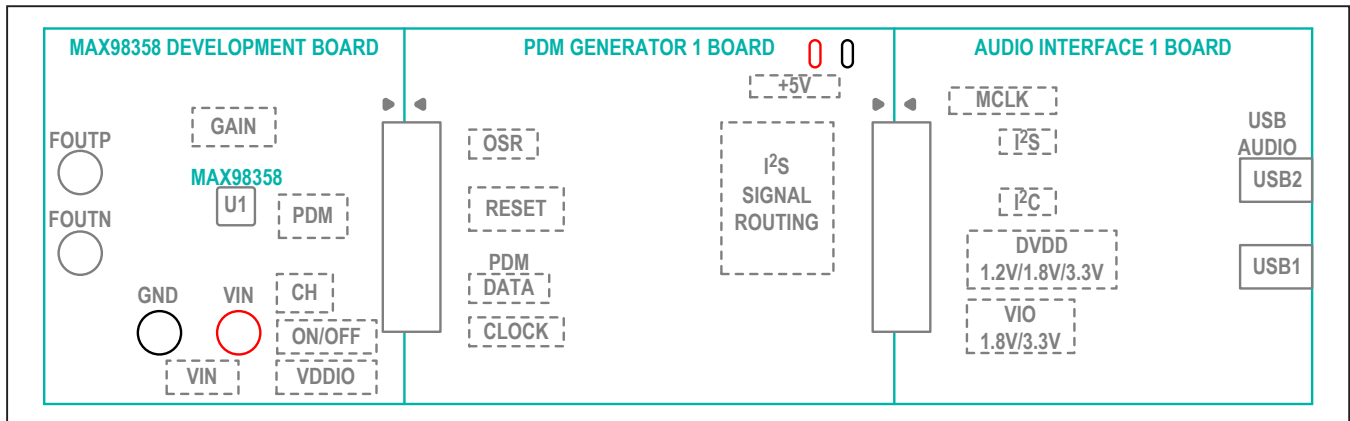

Quick Start

Recommended Equipment

- MAX98358 EV system
- 2.5V to 5.5V, 2A DC power supply
- USB audio source (from computer through an audio media player such as iTunes® or Windows Media® player)
- 4Ω to 8Ω speaker

Procedure

The EV kit is fully assembled and tested. Follow the steps below to verify board operation. **Caution: Do not turn on the power supply until all connections are completed.**

Audio interface board:

- 1) Connect USB cables to USB1 and USB2 on the AUDINT board.
- 2) Set DVDD and VIO to 3.3V on their respective jumpers.
- 3) Set the I²S slider to the connected position.

PDM generator board:

- 4) Set the jumper on JU300 to position 2-3 and connect 5V to 5V_TP loop.
- 5) Apply I²S stream to JU6 header.
 - If the Audio Interface Board is being used, then use the jumpers on JU6. Set the jumpers to connect the XMOS to FPGA pins (position 2-3) for each I²S signal.
 - If I²S data is provided by another means then apply the signal to the column labeled FPGA and the corresponding ground pin is applied to the column labeled GND (position 2-1).
- 6) Upon power-up, the MAXPDMGEN1 board draws roughly 20mA for 5–10 seconds while the on-board FPGA is being programmed. Once the FPGA is programmed and starts to output valid PDM data the supply current drawn by the MAXPDMGEN1 board is roughly 50mA. If the current never increases, then the FPGA has not been programmed.
- 7) Make sure that SW300 and SW301 are in the connected position to route the PDM signals to the J2 header.

- 8) PDM CLK and data signals should be present on the PDMINCLK and PDMINDAT test points on the MAX98358 DEV board.
- 9) To toggle the PDM clock rate between 3.072MHz and 6.144MHz toggle SW302 labeled OSR_SEL. Position 1-2 is 3.072MHz and position 2-3 is the 6.144MHz.

MAX98358 DEV board:

- 10) Verify that shunts are installed as follows:
 - JU2: Pins 1-3 (selects left channel)
 - JU4: Pins 1-2 (power routed from the AUDINT board)
 - JU5: Pins 1-5 (12dB gain)
 - JU6: Pins 2-3 (power routed from the VIN binding post and test point)
 - SW1: Position 1-2 (part is on)
- 11) Set the power supply output to 5V. Disable the power supply.
- 12) Connect the power supply ground terminal to the GND binding post and the power supply positive terminal to the VIN binding post on the DEV board.
- 13) With the audio source disabled, connect the USB audio source to J1 on the DEV board.
- 14) Connect the speaker across the OUTP and OUTN test points.
- 15) Enable the power supply output.
- 16) Enable the audio source.
- 17) Verify that the speakers are playing the audio source signal.

Detailed Description of Hardware

The MAX98358 EV system is designed to allow a thorough evaluation of the MAX98358 PDM digital input Class D power amplifier. The DEV board can be used by itself as a stand-alone evaluation board and driven directly by audio test equipment. The DEV board can also be used in conjunction with the AUDINT board, and PDM GEN board to create an evaluation system. The AUDINT board provides an easy-to-use USB audio to I²S converter. The I²S data is fed to the PDM generator board that uses an FPGA to convert the I²S data stream into a PDM data stream. This allows for any computer to become a digital audio source that can be used to evaluate the device.

The AUDINT board has DC regulators that can be used to power the device. This allows for a quick evaluation from a single USB connection. It should be noted that

iTunes is a registered trademark of Apple Inc.

Windows Media is registered trademark and registered service mark of Microsoft Corporation.

powering the device from the AUDINT board does not allow for high-power evaluation as the input current is limited and evaluation with a speaker is not recommended. Jumpers JU3 and JU4 are used to power the device from the AUDINT board or external supplies connected to test points VIN and VDDIO on the DEV board.

The DEV board operates from a single 2.5V to 5.5V DC power supply and is capable of delivering 3.2W into a 4Ω load and 1.75W into an 8Ω load. The device outputs can be connected directly to a speaker for filterless applications. However, a filter can be added to ease evaluation. The LRC components needed for evaluation of a filtered output are included with the EV kit.

Filterless Output

The DEV board’s filterless outputs (OUTP, OUTN) can be connected directly to a speaker load without any filtering. Use the OUTP and OUTN test points to connect the speaker directly to the device output.

Filtered Output

Audio analyzers typically cannot accept the Class D amplifier’s pulse-width modulated (PWM) signals at their inputs. Therefore, the DEV board features optional low-pass filters at the outputs to ease evaluation. As shipped,

the DEV board’s lowpass filter LRC components are unpopulated and L1 and L2 are shorted on the PCB.

To use the filtered output posts (FOUTP, FOUTN), remove the shorts on L1 and L2 and install components L1, L2, C3–C7, and R5, R6 (provided separately with the DEV board). Use the output posts to connect the filtered outputs to the audio analyzer. The default lowpass filters at the DEV board output are optimized for a 4Ω speaker.

Jumper Selection

Selectable Gain (GAIN)

The DEV board features a 5-pin jumper (JU5) to control the device’s five programmable gain settings. See [Table 1](#) for gain control configuration.

SD_MODE Input

The DEV board features a 4-pin jumper (JU2) to control both the audio channel that is sent to the amplifier output, along with shutdown mode. JU2 is used to select the stereo input data between the left channel, right channel, and left/right channels. **Note:** JU5 must be set to pins 1-2 and a voltage applied to the +3.3V PCB pad for proper operation. See [Table 2](#) for shunt positions.

Table 1. JU5 Jumper Selection (GAIN)

| SHUNT POSITION | GAIN PIN | MAXIMUM GAIN (dB) |
|----------------|--|-------------------|
| 1-2 | Connected to VDD through 100kΩ resistor R1 | 3 |
| 1-3 | Connected to VDD | 6 |
| 1-4 | Connected to GND through 100kΩ resistor R2 | 15 |
| 1-5* | Connected to GND | 12 |
| Not installed | Unconnected | 9 |

*Default position.

Table 2. JU2 Jumper Selection (SD_MODE)

| SHUNT POSITION | SD_MODE PIN | AUDIO CHANNEL |
|----------------|--|------------------------------|
| 1-2 | Connected to VDDIO through R3 (small resistor) | Right |
| 1-3* | Connected to VDDIO through a 2kΩ resistor | Left |
| 1-4 | Connected to VDDIO through R4 (large resistor) | Mono mix (left + right)/2 |

*Default position.

Shutdown Mode

The device features a low-power shutdown mode that is activated by setting jumper SW1 to pins 2-3. To exit shutdown mode, set SW1 to pins 1-2 and select the desired stereo input channel using jumper JU2. See [Table 3](#) for shunt positions.

External/Internal VDDIO (+3.3V)

On the DEV board, a logic voltage from a control interface is needed for proper selection of the stereo input channel through $\overline{SD_MODE}$. This voltage can be applied externally at the VDDIO test point, or it can be provided from circuitry on the AUDINT board. See [Table 4](#) for shunt positions.

Other logic voltages can be used other than +3.3V. If you want to use other logic voltages, resistors R3 and R4 must be adjusted. Refer to the *SD_MODE Pin and Shutdown Operation* section in the MAX98358 IC data sheet for more information.

External/Internal Input Supply (VDD)

The device can accept an input supply from +2.5V to +5.5V. This voltage can be applied externally at the VDD and GND PCB pads, or it can be provided from the AUDINT board. See [Table 5](#) for JU6 shunt positions.

Audio Interface Board (AUDINT Board)

The AUDINT board provides USB-to-I²S data conversion, as well as DC regulators that can be used to power the device. The USB-to-I²S converter on the AUDINT board allows for any computer to become an I²S digital audio source. This allows for a quick evaluation from a single USB connection. Using the AUDINT board as a power supply for high-power evaluation is not recommended as the input current is limited. For high-power evaluation, use an external supply connected to VIN.

PDM Generator Board (PDM GEN Board)

The PDM GEN board provides a seamless means to convert an I²S data stream into a PDM data stream. The PDM GEN board also has its own set of DC regulators so that the system can be powered from a single 5V supply. The PDM generator board must be powered externally at +5V_{TP}.

Driving PDM Directly

To drive PDM directly, make sure that the sliders (SW300 and SW301) are in the disconnected position or the DEV board is physically separated from the rest of the EV SYS. Apply signals at the PDMINDAT and PDMINCLK test points or between J3 pins 1-2 at the appropriate locations (pin 1 is signal ground).

Table 3. SW1 Jumper Selection

| SHUNT POSITION | VDDIO VOLTAGE | DEVICE OPERATION |
|----------------|---|--|
| 1-2* | VDDIO determined by JU4 jumper position | Normal (input channel selected through JU2 setting) |
| 2-3 | Connected to GND | Shutdown |

*Default position.

Table 4. JU4 Jumper Selection

| SHUNT POSITION | LOGIC VOLTAGE (VDDIO) |
|----------------|--|
| 1-2* | 3.3V supplied by AUDINT board connected to the J1 header. |
| 2-3 | User-supplied external power supply applied at the VDDIO test point. |

*Default position.

Table 5. JU6 Jumper Selection

| SHUNT POSITION | INPUT VOLTAGE (VIN) |
|----------------|---|
| Installed* | VDD supplied from the AUDINT board connected to J1 header. |
| Not installed | User-supplied external power supply applied at the VIN PCB pad. |

*Default position.

Ordering Information

| PART | TYPE |
|--------------------|--|
| MAX98358DEV#TQFN | Development Board (DEV board only) |
| MAX98358EVSYS#TQFN | Evaluation System (DEV + AUDINT boards) |
| MAX98358DEV#WLP | Development Board (DEV board only) |
| MAX98358EVSYS#WLP | Evaluation System (DEV + AUDINT boards) |

#Denotes RoHS compliant.

MAX98358 EV Kit Bill of Materials (TQFN)

| ITEM | COMPONENT DESIGNATOR | DNI | QTY | MFG. | MFG. PART NO. | DESCRIPTION |
|------|--------------------------------------|-----|-----|---------------------|-------------------|---|
| 1 | C1 | | 1 | Murata | GRM188R60J106K | 10uF ±10%, 6.3V X5R ceramic capacitor (0603) |
| 2 | C2 | | 1 | Murata | GRM155R71C104K | 0.1uF ±10%, 16V X7R ceramic capacitor (0402) |
| 3 | C3, C4, C5, C6, C7, C8, C9, C10, C11 | DNI | 9 | | | OPEN, ceramic capacitor (0402) |
| 4 | FB1, FB2 | | 2 | | | 0 ohms ±5% resistor (0603) |
| 5 | J1 | | 1 | Samec | TSW-113-08-S-D-RA | 26-pin (2x13) dual row right-angle header, 0.1in centers |
| 6 | J3 | | 1 | Sullins | PEC36DAAN | 4-pin header, 0.1in centers |
| 7 | JU2 | | 1 | Sullins | PEC36SAAN | 4-pin header, 0.1in centers |
| 8 | JU4, JU6 | | 2 | Sullins | PEC36SAAN | 3-pin header, 0.1in centers |
| 9 | JU5 | | 1 | Sullins | PEC36SAAN | 5-pin header, 0.1in centers |
| 10 | L1, L2 | DNI | 2 | Toko | A916CY-220M | PC SHORT, inductor (6.2mm x 6.3mm) |
| 11 | R1, R2 | | 2 | | | 100k Ohm ±5% resistor (0603) |
| 12 | R3 | | 1 | | | 226k Ohm ±1% resistor (0603) |
| 13 | R4 | | 1 | | | 634k Ohm ±1% resistor (0603) |
| 14 | R5, R6 | DNI | 2 | | | OPEN, resistor (0402) |
| 15 | R7, R8 | | 2 | | | 0 ohms ±5% resistor (0402) |
| 16 | R10 | | 1 | | | 2k Ohm ±1% resistor (0603) |
| 17 | SW1 | | 1 | ITW Pancon | JSC416G0 | 3-pin header switch, 0.1in centers |
| 18 | U1 | | 1 | MAXIM | MAX98358ETE+ | PDM Input Class D Audio Power Amplifier (16 pin TQFN) |
| 19 | OUTP | | 1 | Keystone | 5012 | Multi-purpose test point (White) |
| 20 | OUTN, GND, GND, GND, GND, GND, GND | | 7 | Keystone | 5011 | Multi-purpose test point (Black) |
| 21 | GND, VIN, FOUTP, FOUTN | | 4 | Johnson | 111-2223-001 | Binding Posts |
| 22 | PDMINDAT, PDMINCLK | | 2 | Keystone | 5013 | Multi-purpose test point (Orange) |
| 23 | VDDIO | | 1 | Keystone | 5010 | Multi-purpose test point (Red) |
| 24 | MAX98358 TQFN DEVELOPMENT BOARD | | 1 | | | PCB |
| 25 | VIN, GND, OUTP, OUTN, GND | | 5 | Weico Wire | 9020 Buss | Wire, Buss, 20G plated solid copper 0.25 inch U-shape wire loop |
| 26 | | | 4 | Keystone | 2203 | Aluminum standoff, round, 4-40 thread, 0.187" OD, 0.5"L |
| 27 | | | 4 | B&F Fastener Supply | PMSSS4400038PH | Machine screw, philips, 4-40, 3/8" length |
| 28 | | | 4 | | | Shunt |

*DNI = DO NOT INSTALL

MAX98358 EV Kit Schematics (TQFN)

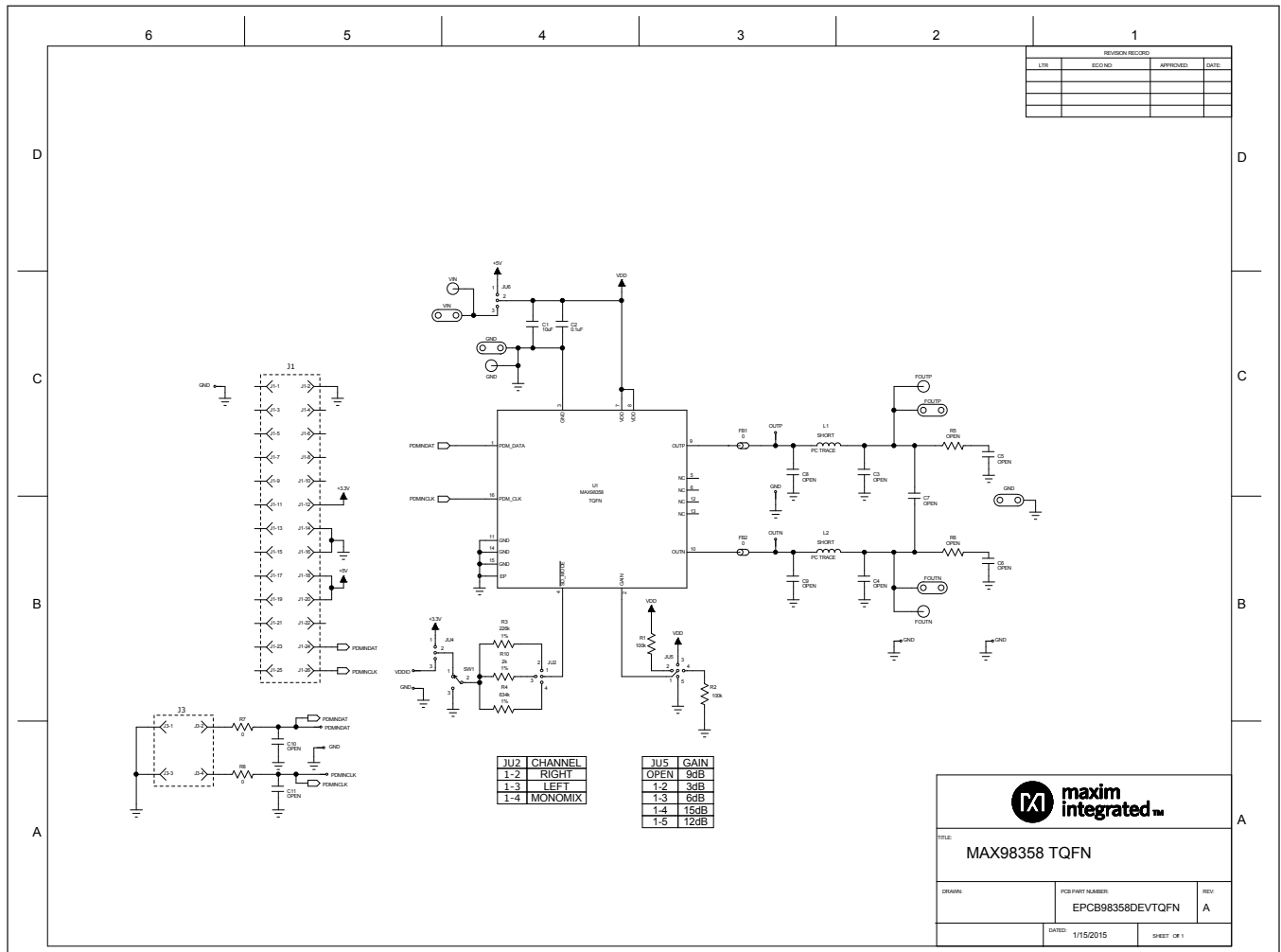

MAX98358 EV Kit PCB Layout (TQFN)

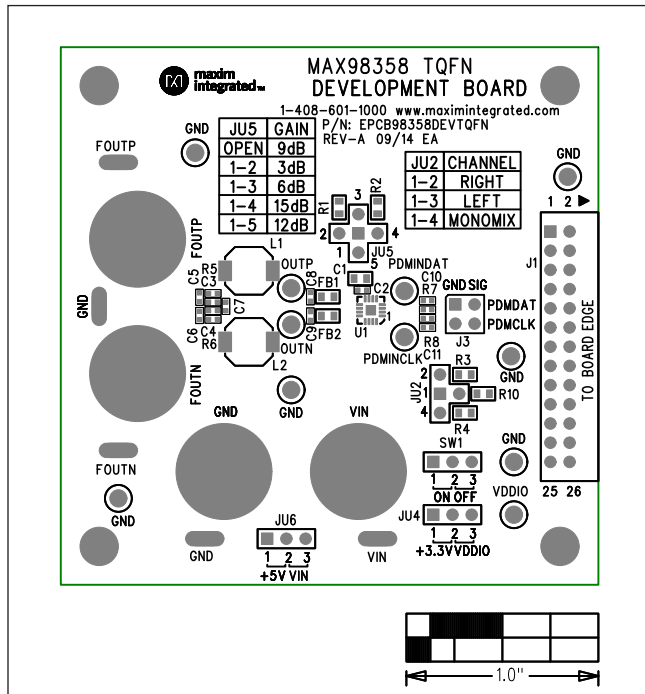

MAX98358 EV Kit PCB (TQFN) Top Silkscreen

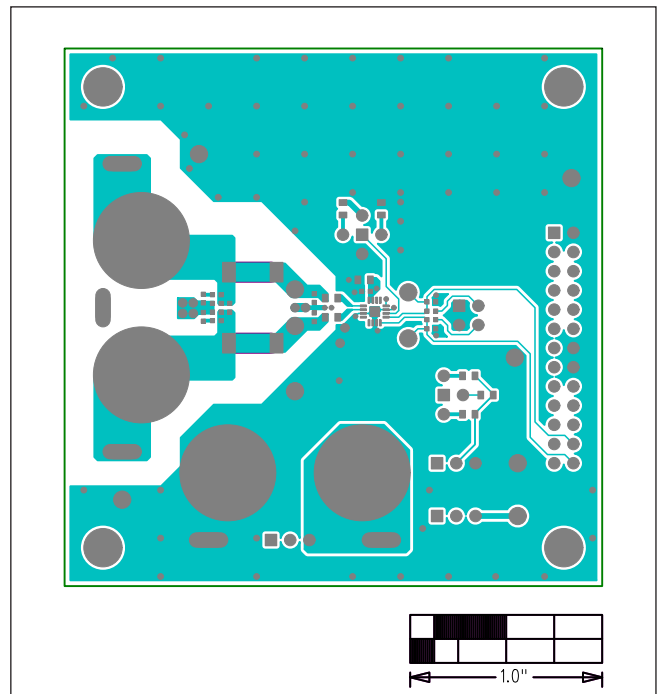

MAX98358 EV Kit PCB (WLP) Component Side

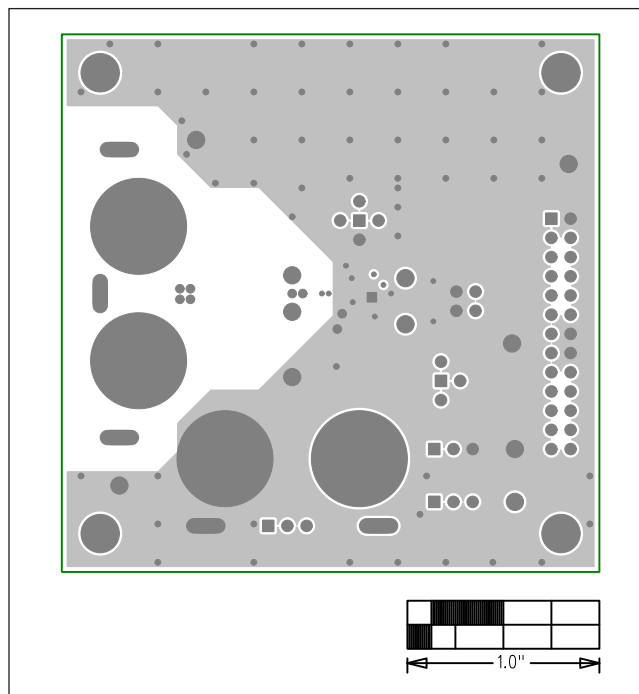

MAX98358 EV Kit PCB (TQFN) Layer 2 Ground

MAX98358 EV Kit PCB Layout (TQFN) (continued)

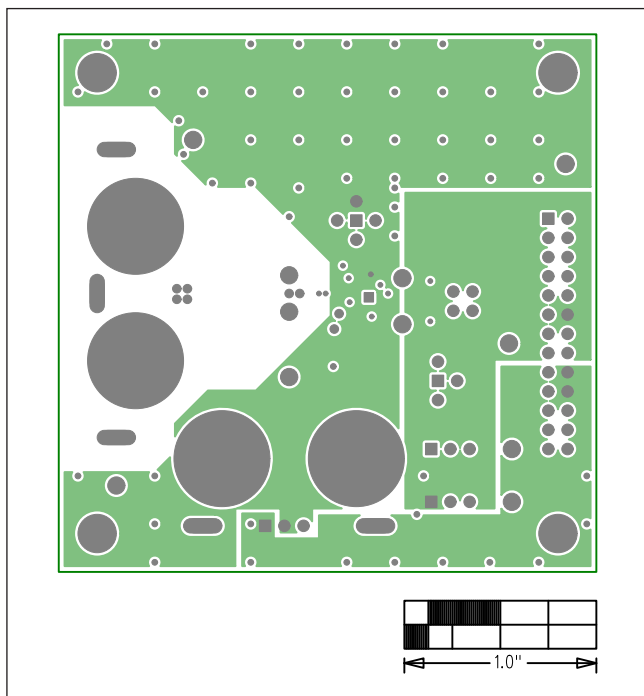

MAX98358 EV Kit PCB (TQFN) Layer 3 Power

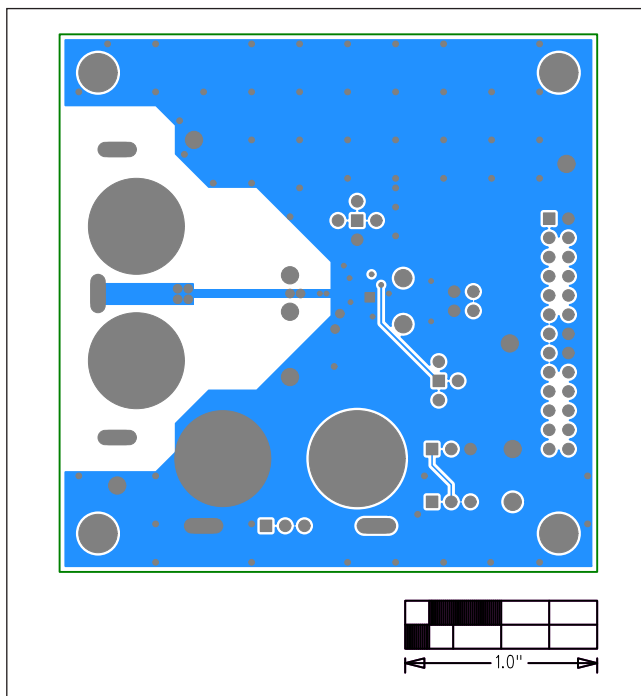

MAX98358 EV Kit PCB (TQFN) Solder Side

MAX98358 EV Kit Bill of Materials (WLP)

| ITEM | COMPONENT DESIGNATOR | DNI | QTY | MFG. | MFG. PART NO. | DESCRIPTION |
|------|--------------------------------------|-----|-----|---------------------|-------------------|---|
| 1 | C1 | | 1 | Murata | GRM188R60J106K | 10uF ±10%, 6.3V X5R ceramic capacitor (0603) |
| 2 | C2 | | 1 | Murata | GRM155R71C104K | 0.1uF ±10%, 16V X7R ceramic capacitor (0402) |
| 3 | C3, C4, C5, C6, C7, C8, C9, C10, C11 | DNI | 9 | | | OPEN, ceramic capacitor (0402) |
| 4 | FB1, FB2 | | 2 | | | 0 ohms ±5% resistor (0603) |
| 5 | J1 | | 1 | Samec | TSW-113-08-S-D-RA | 26-pin (2x13) dual row right-angle header, 0.1in centers |
| 6 | J3 | | 1 | Sullins | PEC36DAAN | 4-pin header, 0.1in centers |
| 7 | JU2 | | 1 | Sullins | PEC36SAAN | 4-pin header, 0.1in centers |
| 8 | JU4, JU6 | | 2 | Sullins | PEC36SAAN | 3-pin header, 0.1in centers |
| 9 | JU5 | | 1 | Sullins | PEC36SAAN | 5-pin header, 0.1in centers |
| 10 | L1, L2 | DNI | 2 | Toko | A916CY-220M | PC SHORT, inductor (6.2mm x 6.3mm) |
| 11 | R1, R2 | | 2 | | | 100k Ohm ±5% resistor (0603) |
| 12 | R3 | | 1 | | | 226k Ohm ±1% resistor (0603) |
| 13 | R4 | | 1 | | | 634k Ohm ±1% resistor (0603) |
| 14 | R5, R6 | DNI | 2 | | | OPEN, resistor (0402) |
| 15 | R7, R8 | | 2 | | | 0 ohms ±5% resistor (0402) |
| 16 | R10 | | 1 | | | 2k Ohm ±1% resistor (0603) |
| 17 | SW1 | | 1 | ITW Pancon | JSC416G0 | 3-pin header switch, 0.1in centers |
| 18 | U1 | | 1 | MAXIM | MAX98358EWL+ | PDM Input Class D Audio Power Amplifier (9 bump WLP) |
| 19 | OUTP | | 1 | Keystone | 5012 | Multi-purpose test point (White) |
| 20 | OUTN, GND, GND, GND, GND, GND, GND | | 7 | Keystone | 5011 | Multi-purpose test point (Black) |
| 21 | GND, VIN, FOUTP, FOUTN | | 4 | Johnson | 111-2223-001 | Binding Posts |
| 22 | PDMINDAT, PDMINCLK | | 2 | Keystone | 5013 | Multi-purpose test point (Orange) |
| 23 | VDDIO | | 1 | Keystone | 5010 | Multi-purpose test point (Red) |
| 24 | | | 4 | | | Shunt |
| 25 | MAX98358 WLP DEVELOPMENT BOARD | | 1 | | | PCB |
| 26 | VIN, GND, OUTP, OUTN, GND | | 5 | Weico Wire | 9020 Buss | Wire, Buss, 20G plated solid copper 0.25 inch U-shape wire loop |
| 27 | | | 4 | Keystone | 2203 | Aluminum standoff, round, 4-40 thread, 0.187" OD, 0.5"L |
| 28 | | | 4 | B&F Fastener Supply | PMSSS4400038PH | Machine screw, philips, 4-40, 3/8" length |

*DNI = DO NOT INSTALL

MAX98358 EV Kit Schematics (WLP)

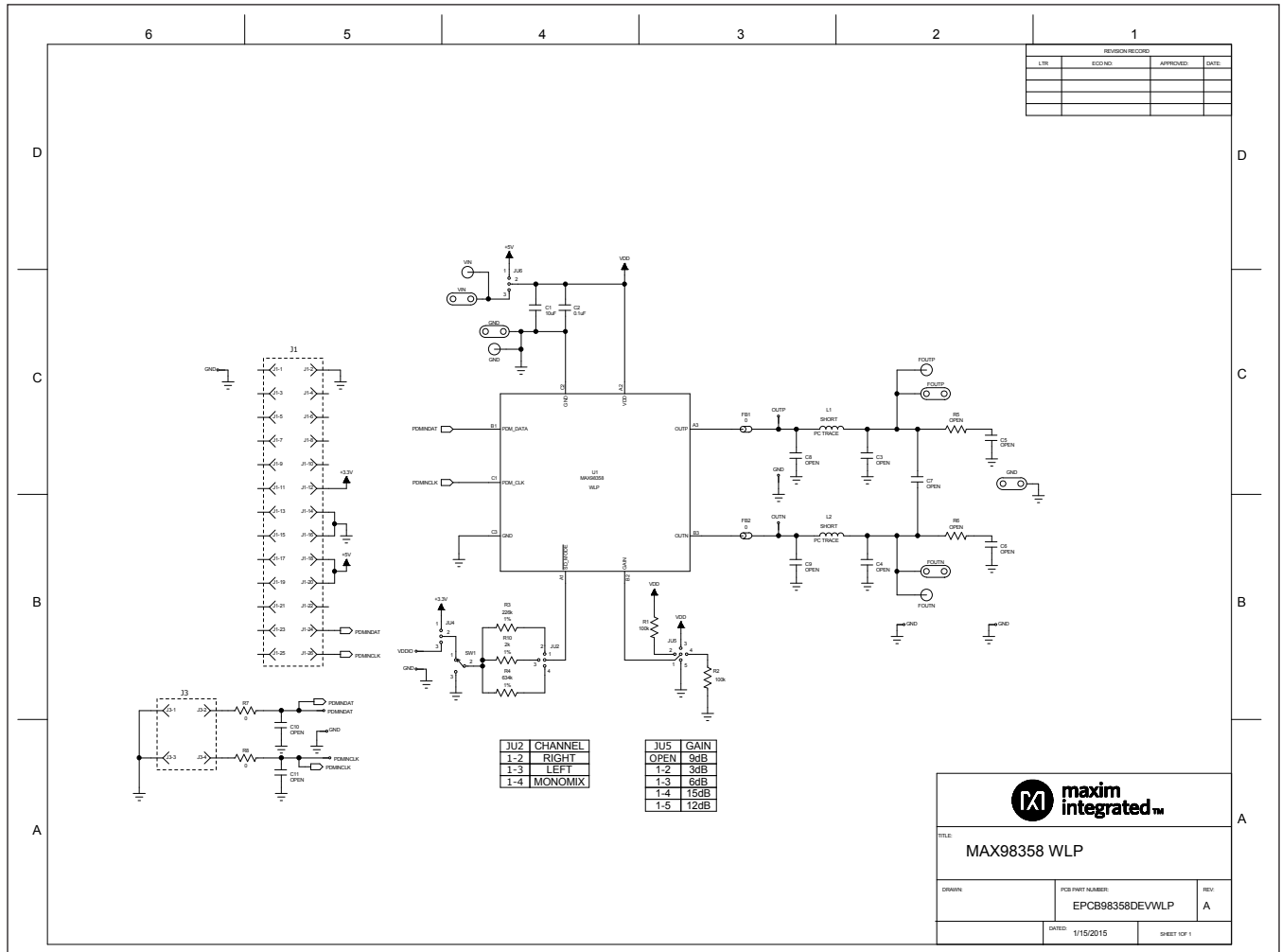

MAX98358 EV Kit PCB Layout (WLP)

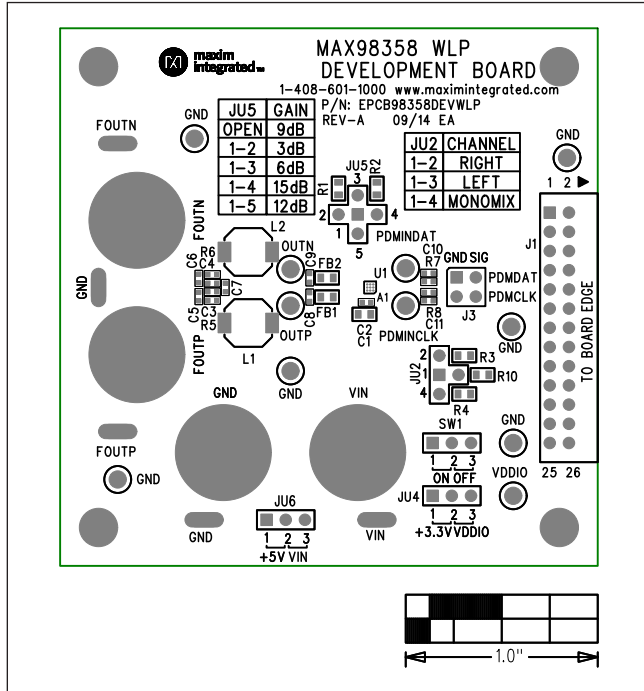

MAX98358 EV Kit PCB (WLP) Top Silkscreen

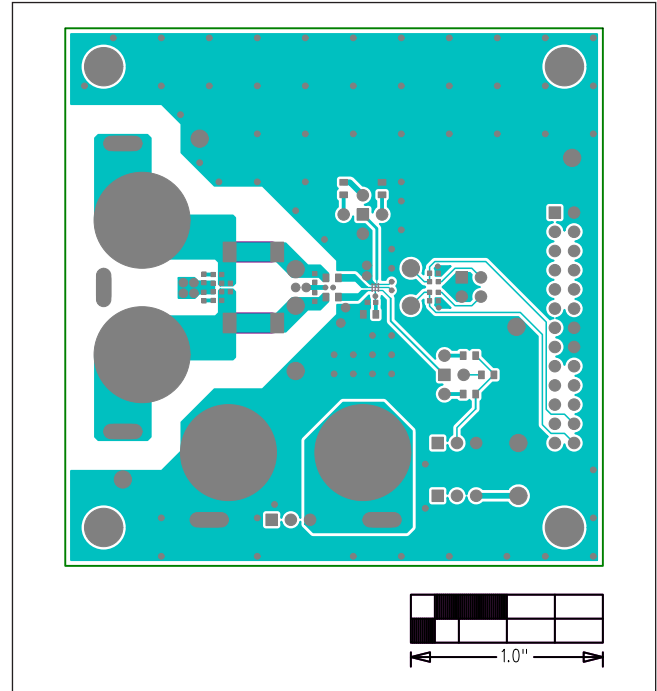

MAX98358 EV Kit PCB (WLP) Component Side

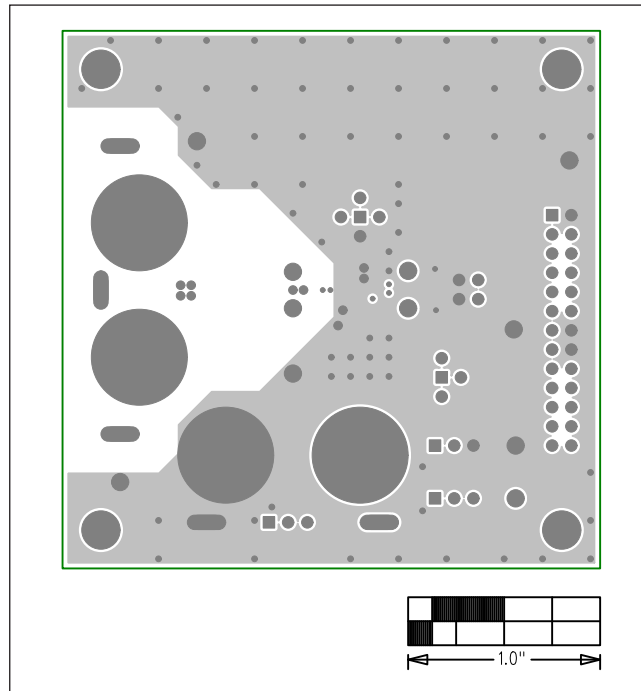

MAX98358 EV Kit PCB (WLP) Layer 2 Ground

MAX98358 EV Kit PCB Layout (WLP) (continued)

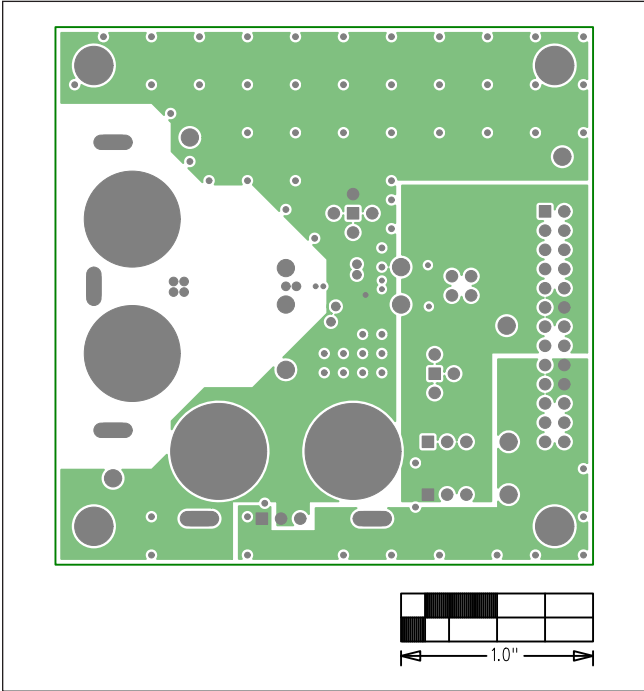

MAX98358 EV Kit PCB (WLP) Layer 3

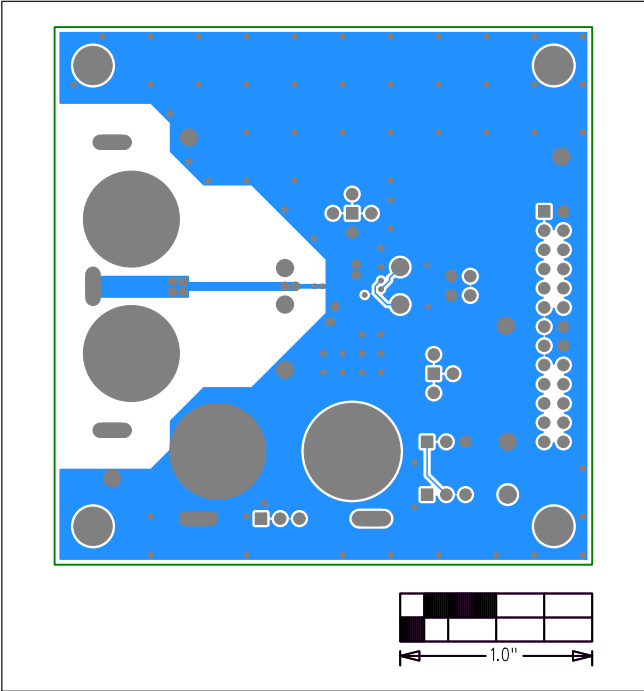

MAX98358 EV Kit PCB (WLP) Solder Side

Revision History

| REVISION NUMBER | REVISION DATE | DESCRIPTION | PAGES CHANGED |
|-----------------|---------------|-----------------|---------------|
| 0 | 2/17 | Initial release | — |

For pricing, delivery, and ordering information, please contact Maxim Direct at 1-888-629-4642, or visit Maxim Integrated's website at www.maximintegrated.com.

Maxim Integrated cannot assume responsibility for use of any circuitry other than circuitry entirely embodied in a Maxim Integrated product. No circuit patent licenses are implied. Maxim Integrated reserves the right to change the circuitry and specifications without notice at any time.