

CD54/74HC109 CD54/74HCT109

High-Speed CMOS Logic

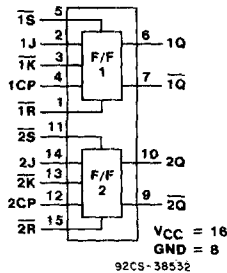

FUNCTIONAL DIAGRAM

Dual J-K Flip-Flop with Set and Reset

Type Features:

- Positive-Edge triggered
- Asynchronous Set and Reset
- 60 MHz Typical Maximum Clock Frequency @ $V_{CC} = 5\text{ V}$, $C_L = 15\text{ pF}$, $T_A = 25^\circ\text{ C}$
- Typical Propagation Delay = 18 ns @ $V_{CC} = 5\text{ V}$, $C_L = 15\text{ pF}$, $T_A = 25^\circ\text{ C}$
- Schmitt Trigger Clock Inputs

The RCA-CD54/74HC109 and CD54/74HCT109 are dual J-K flip-flops with set and reset. The flip-flop changes state with the positive transition of Clock (1CP and 2CP).

The flip-flop is set and reset by active-low \bar{S} and \bar{R} , respectively. A low on both the set and reset inputs simultaneously will force both Q and \bar{Q} outputs high. However, both set and reset going high simultaneously results in an unpredictable output condition.

The CD54HC109 and CD54HCT109 are supplied in 16-lead hermetic dual-in-line ceramic packages (F suffix). The CD74HC109 and CD74HCT109 are supplied in 16-lead dual-in-line plastic packages (E suffix) and in 16-lead dual-in-line surface mount plastic packages (M suffix). Both types are also available in chip form (H suffix).

Family Features:

- Fanout (Over Temperature Range):
Standard Outputs - 10 LSTTL Loads
- Bus Driver Outputs - 15 LSTTL Loads
- Wide Operating Temperature Range:
CD74HC/HCT: -40 to $+85^\circ\text{ C}$
- Balanced Propagation Delay and Transition Times
- Significant Power Reduction Compared to LSTTL Logic ICs
- Alternate Source is Philips/Signetics
- CD54HC/CD74HC Types:
2 to 6 V Operation
High Noise Immunity: $N_L = 30\%$, $N_{IH} = 30\%$ of V_{CC} @ $V_{CC} = 5\text{ V}$
- CD54HCT/CD74HCT Types:
4.5 to 5.5 V Operation
Direct LSTTL Input Logic Compatibility
 $V_{IL} = 0.8\text{ V Max.}$, $V_{IH} = 2\text{ V Min.}$
CMOS Input Compatibility
 $I_i \leq 1\text{ uA}$ @ V_{OL} , V_{OH}

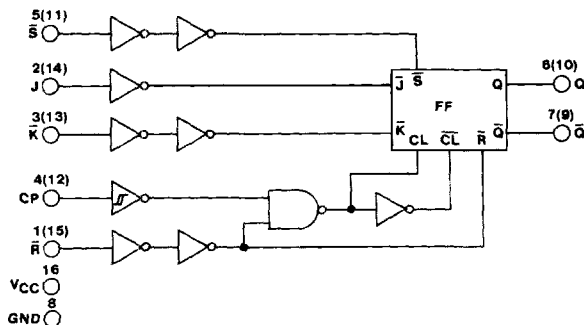

Fig. 1 - Logic diagram

TRUTH TABLE

Inputs					Outputs	
\bar{S}	\bar{R}	CP	J	\bar{K}	Q	\bar{Q}
L	H	X	X	X	H	L
L	L	X	X	X	L	H
L	L	X	X	X	H*	H*
H	H	---	L	L	L	H
H	H	---	H	L	TOGGLE	
H	H	---	L	H	NO CHANGE	
H	H	---	H	H	H	L
H	H	L	X	X	NO CHANGE	

*Unpredictable and unstable condition if both \bar{S} and \bar{R} go high simultaneously.

CD54/74HC109 CD54/74HCT109

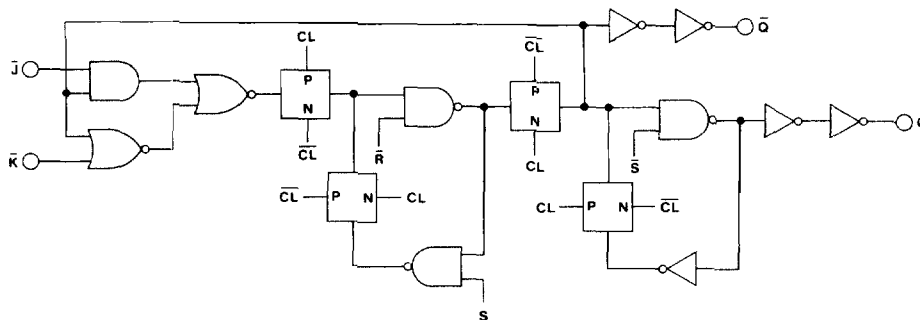

92CM-38536

DETAIL OF FLIP-FLOP

MAXIMUM RATINGS, Absolute-Maximum Values:

DC SUPPLY-VOLTAGE, (V_{CC}):		
(Voltages referenced to ground)		-0.5 to +7 V
DC INPUT DIODE CURRENT, I_{IK} (FOR $V_i < -0.5$ V OR $V_i > V_{CC} + 0.5$ V)		± 20 mA
DC OUTPUT DIODE CURRENT, I_{OK} (FOR $V_o < -0.5$ OR $V_o > V_{CC} + 0.5$ V)		± 20 mA
DC DRAIN CURRENT, PER OUTPUT (I_o) (FOR -0.5 V $< V_o < V_{CC} + 0.5$ V)		± 25 mA
DC V_{CC} OR GROUND CURRENT (I_{CC}):		± 50 mA
POWER DISSIPATION PER PACKAGE (P_o):		
For $T_A = -40$ to $+60^\circ\text{C}$ (PACKAGE TYPE E)		500 mW
For $T_A = +60$ to $+85^\circ\text{C}$ (PACKAGE TYPE E)	Derate Linearly at 8 mW/ $^\circ\text{C}$ to 300 mW	500 mW
For $T_A = -55$ to $+100^\circ\text{C}$ (PACKAGE TYPE F, H)		500 mW
For $T_A = +100$ to $+125^\circ\text{C}$ (PACKAGE TYPE F, H)	Derate Linearly at 8 mW/ $^\circ\text{C}$ to 300 mW	500 mW
For $T_A = -40$ to $+70^\circ\text{C}$ (PACKAGE TYPE M)		400 mW
For $T_A = +70$ to $+125^\circ\text{C}$ (PACKAGE TYPE M)	Derate Linearly at 6 mW/ $^\circ\text{C}$ to 70 mW	400 mW
OPERATING - TEMPERATURE RANGE (T_A):		
PACKAGE TYPE F, H		-55 to $+125^\circ\text{C}$
PACKAGE TYPE E, M		-40 to $+85^\circ\text{C}$
STORAGE TEMPERATURE (T_{sig})		-65 to $+150^\circ\text{C}$
LEAD TEMPERATURE (DURING SOLDERING):		
At distance $1/16 \pm 1/32$ in. (1.59 ± 0.79 mm) from case for 10 s max.		$+265^\circ\text{C}$
Unit inserted into a PC Board (min. thickness $1/16$ in., 1.59 mm) with solder contacting lead tips only		$+300^\circ\text{C}$

RECOMMENDED OPERATING CONDITIONS:

For maximum reliability, nominal operating conditions should be selected so that operation is always within the following ranges:

CHARACTERISTIC	LIMITS		UNITS
	MIN.	MAX.	
Supply-Voltage Range (For $T_A =$ Full Package-Temperature Range) V_{CC} .*			
CD54/74HC Types	2	6	V
CD54/74HCT Types	4.5	5.5	V
DC Input or Output Voltage V_i, V_o	0	V_{CC}	V
Operating Temperature T_A :			
CD74 Types	-40	+85	$^\circ\text{C}$
CD54 Types	-55	+125	
Input rise and Fall Times t_r, t_f			
All inputs Except CP	at 2 V	0	1000
	at 4.5 V	0	500
	at 6 V	0	400
Input Rise and Fall Times t_r, t_f			
For CP	at 2 V	0	unlimited
	at 4.5 V	0	
	at 6 V	0	

*Unless otherwise specified, all voltages are referenced to Ground.

CD54/74HC109 CD54/74HCT109

SWITCHING CHARACTERISTICS ($V_{CC} = 5\text{ V}$, $T_A = 25^\circ\text{C}$, Input $t_{r,i} = 6\text{ ns}$)

CHARACTERISTIC		C_L (pF)	Typical		UNITS
			54/74HC	54/74HCT	
Propagation Delay, CP → Q, \bar{Q}	t_{PLH} t_{PHL}	15	14	17	ns
$\bar{S} \rightarrow Q$	t_{PLH}	15	9	12	ns
$\bar{S} \rightarrow \bar{Q}$	t_{PHL}	15	13	19	ns
$\bar{R} \rightarrow Q$	t_{PHL}	15	15	19	ns
$\bar{R} \rightarrow \bar{Q}$	t_{PLH}	15	14	15	ns
CP Frequency	f_{MAX}	15	60	54	MHz
Power Dissipation Capacitance*	C_{PD}^*	—	30	33	pF

* C_{PD} is used to determine the dynamic power consumption, per flip-flop.

PD = $C_{PD} V_{CC}^2 f_i + \sum V_{CC}^2 C_L f_o$ where:

f_i = Input Frequency

C_L = Output Load Capacitance

V_{CC} = Supply Voltage

f_o = Output Frequency

PREREQUISITE FOR SWITCHING FUNCTION

CHARACTERISTIC	TEST CONDITION	LIMITS												UNITS
		25°C				-40°C to +85°C				-55°C to +125°C				
		HC		HCT		74HC		74HCT		54HC		54HCT		
		Min.	Max.	Min.	Max.	Min.	Max.	Min.	Max.	Min.	Max.	Min.	Max.	
Set-up Time J, \bar{K} to CP	t_{SU}	2	80	—	—	100	—	—	—	120	—	—	—	ns
		4.5	16	18	—	20	—	23	—	24	—	27	—	
		6	14	—	—	17	—	—	—	20	—	—	—	
Hold Time J, \bar{K} to CP	t_H	2	5	—	—	5	—	—	—	5	—	—	—	ns
		4.5	5	3	—	5	—	3	—	5	—	3	—	
		6	5	—	—	5	—	—	—	5	—	—	—	
Removal Time \bar{R} , \bar{S} to CP	t_{REM}	2	80	—	—	100	—	—	—	120	—	—	—	ns
		4.5	16	18	—	20	—	23	—	24	—	27	—	
		6	14	—	—	17	—	—	—	20	—	—	—	
Pulse Width CP, \bar{R} , \bar{S}	t_W	2	80	—	—	100	—	—	—	120	—	—	—	ns
		4.5	16	18	—	20	—	23	—	24	—	27	—	
		6	14	—	—	17	—	—	—	20	—	—	—	
CP Frequency	f_{MAX}	2	6	—	—	5	—	—	—	4	—	—	—	MHz
		4.5	30	27	—	25	—	22	—	20	—	18	—	
		6	35	—	—	29	—	—	—	23	—	—	—	

CD54/74HC109 CD54/74HCT109

SWITCHING CHARACTERISTICS ($C_L = 50 \text{ pF}$, Input $t_r, t_f = 6 \text{ ns}$)

CHARACTERISTIC	V_{CC}	25° C				-40° C to + 85° C				-55° C to + 125° C				UNITS
		HC		HCT		74HC		74HCT		54HC		54HCT		
		Min.	Max.	Min.	Max.	Min.	Max.	Min.	Max.	Min.	Max.	Min.	Max.	
Propagation Delay, $CP \rightarrow Q, \bar{Q}$	t_{PHL}	2	175	—	—	220	—	—	—	265	—	—	ns	
	t_{PLH}	4.5	35	40	44	50	53	60	—	—	—			
		6	30	—	37	—	45	—	—	—	—			
$\bar{S} \rightarrow Q$	t_{PLH}	2	120	—	—	150	—	—	180	—	—	ns		
		4.5	24	30	30	38	36	45	—	—	—			
		6	20	—	26	—	31	—	—	—	—			
$\bar{S} \rightarrow \bar{Q}$	t_{PHL}	2	155	—	—	195	—	—	235	—	—	ns		
		4.5	31	45	39	56	47	68	—	—	—			
		6	26	—	33	—	40	—	—	—	—			
$\bar{R} \rightarrow Q$	t_{PHL}	2	185	—	—	230	—	—	280	—	—	ns		
		4.5	37	45	46	56	56	68	—	—	—			
		6	31	—	39	—	48	—	—	—	—			
$\bar{R} \rightarrow \bar{Q}$	t_{PLH}	2	170	—	—	215	—	—	255	—	—	ns		
		4.5	34	37	43	46	51	56	—	—	—			
		6	29	—	37	—	43	—	—	—	—			
Transition Times	t_{TLH}	2	75	—	—	95	—	—	110	—	—	ns		
	t_{THL}	4.5	15	15	19	19	22	22	—	—	—			
		6	13	—	16	—	19	—	—	—	—			
Input Capacitance	C_i		—	—	—	—	—	—	—	—	—	μF		
			10	10	10	10	10	10	10	10	10			
			—	—	—	—	—	—	—	—	—			

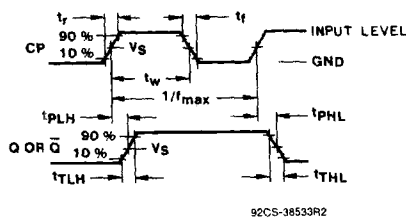

Fig. 2 - Clock to output delays and clock pulse width.

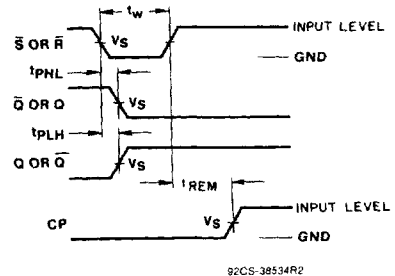

Fig. 3 - \bar{R} or \bar{S} prerequisite and propagation delays.

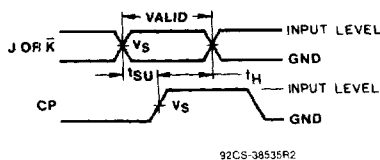

Fig. 4 - Data set-up and hold times.

	54/74 HC	54/74 HCT
Input Level	V_{CC}	3V
Switching Voltage, V_s	50% V_{CC}	1.3V