



LoRa Module for ESP32 DIY Development Kit

SKU: M005

LoRa integrated LoRa Module Ra-02, designed and produced by Ai-Thinker. On the board has some extra space left over, so we give you a prototyping area, it's great for adding on your customized circuit working with the LoRa Module.

LoRa enables long-range transmissions (more than 10 km in rural areas) with low power consumption. The technology is presented in two parts: LoRa, the physical layer and LoRaWAN (Long Range Wide Area Network), the upper layers.

LoRa and LoRaWAN permit long-range connectivity for Internet of Things (IoT) devices in different types of industries.

Product Features

- Lora Module: Ra-02 (by Ai-Thinker)
- Series Communication Protocol: SPI
- Universal Perboard
- Working Frequency: 433 MHz
- Supports FSK, GFSK, MSK, GMSK, LoRa™ and OOK modulation modes
- Receive sensitivity: lowest to -141 dBm
- Programmable bit rate up to 300Kbps
- Build-in PCB Antenna
- External Antenna port
- Program platform: Arduino, Mrcopython, UIFlow(Blockly)

Kit includes

- 1x M5Stack LoRa Module

Applications

- Automatic meter reading
- Home building automation
- Remote irrigation system

Example

Arduino IDE

These are the point-to-point communication examples between two LORA modules. The LoRa nodes send and receive messages.

- Blue string indicates send succeed.
- Yellow string display the received messages.
- Red string indicates initialization failed.

To get complete code, please click [here](#)

```
#include <M5Stack.h>
#include <M5LoRa.h>

//declaration
String outgoing;           // outgoing message
byte msgCount = 0;        // count of outgoing messages
byte localAddress = 0xBB; // address of this device
byte destination = 0xFF;  // destination to send to
```

```

//initialization
M5.begin();
LoRa.setPins();                // set CS, reset, IRQ pin
LoRa.begin(433E6);            // initialize ratio at 915 MHz

//send message
void sendMessage(String outgoing) {
  LoRa.beginPacket();          // start packet
  LoRa.write(destination);     // add destination address
  LoRa.write(localAddress);    // add sender address
  LoRa.write(msgCount);        // add message ID
  LoRa.write(outgoing.length()); // add payload length
  LoRa.print(outgoing);        // add payload
  LoRa.endPacket();           // finish packet and send it
  msgCount++;                 // increment message ID
}

//receive message
void onReceive(int packetSize) {
  if (packetSize == 0) return; // if there's no packet, return
  int recipient = LoRa.read();  // recipient address
  byte sender = LoRa.read();    // sender address
  byte incomingMsgId = LoRa.read(); // incoming msg ID
  byte incomingLength = LoRa.read(); // incoming msg length

  String incoming = "";

  while (LoRa.available()) {
    incoming += (char)LoRa.read();
  }
}

onReceive(LoRa.parsePacket());

```



Schematic

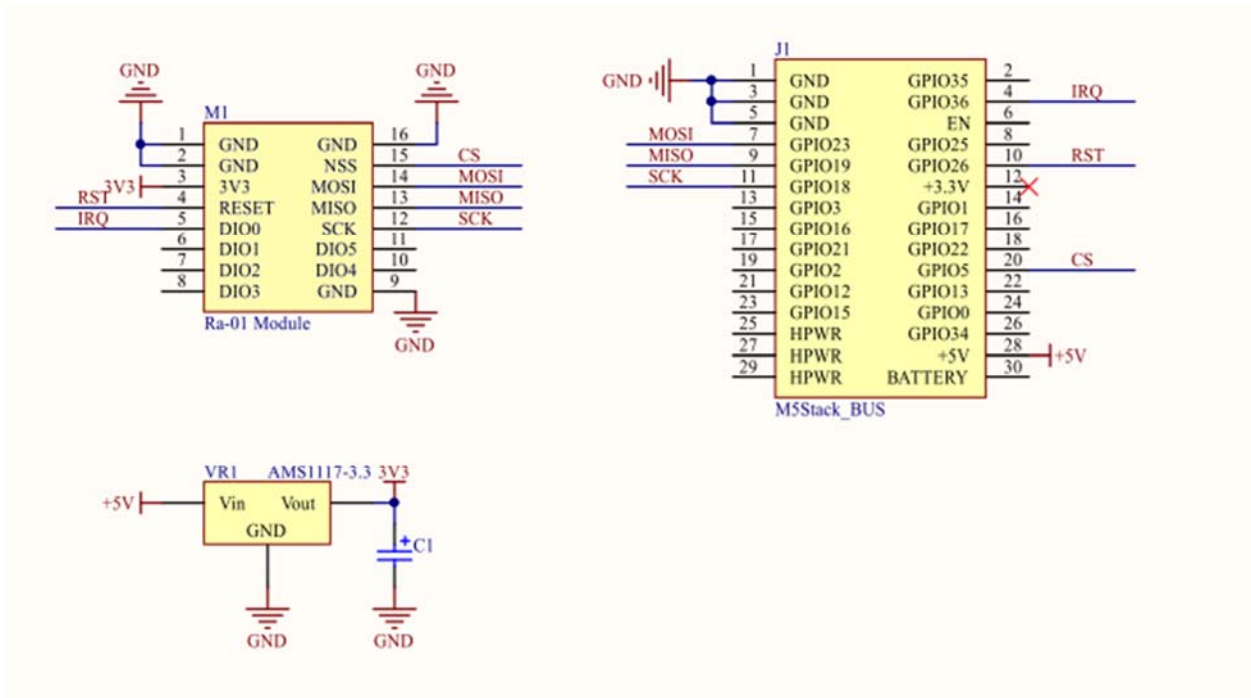

Built-in Antenna



GPIO5->NSS
 GPIO26->RST
 GPIO36->IRQ

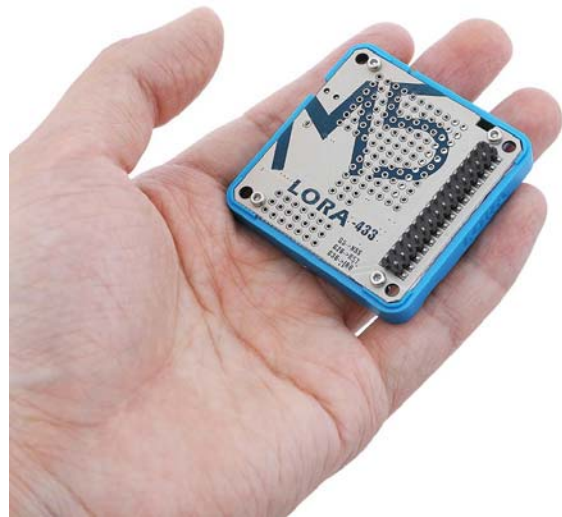



<https://m5stack.com/products/lora-module/10-2-19>