

Revision level		Revision Record	Changed	Date	Approved	Date
Drawing	Part					
00	-	SEE ECN# 012255	CJR	01/03/2013	CJR	01/03/2013

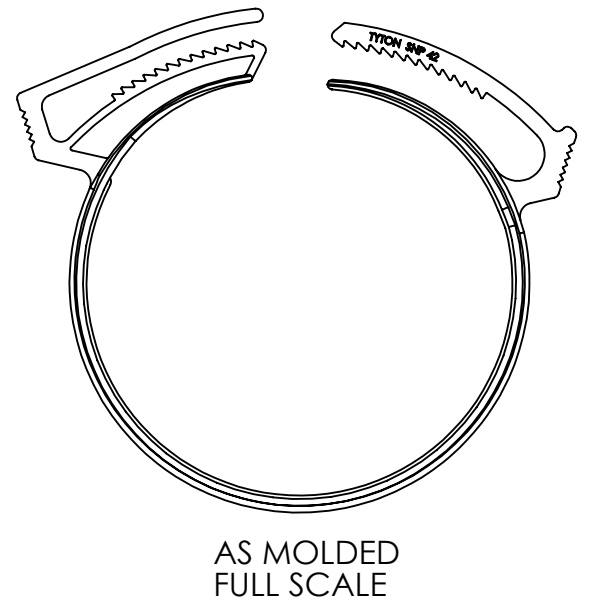
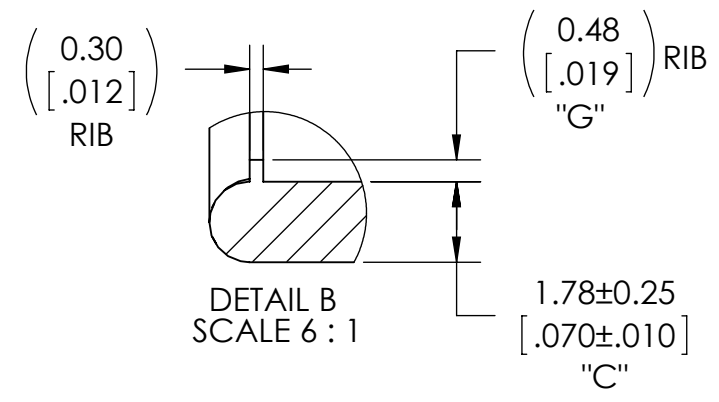
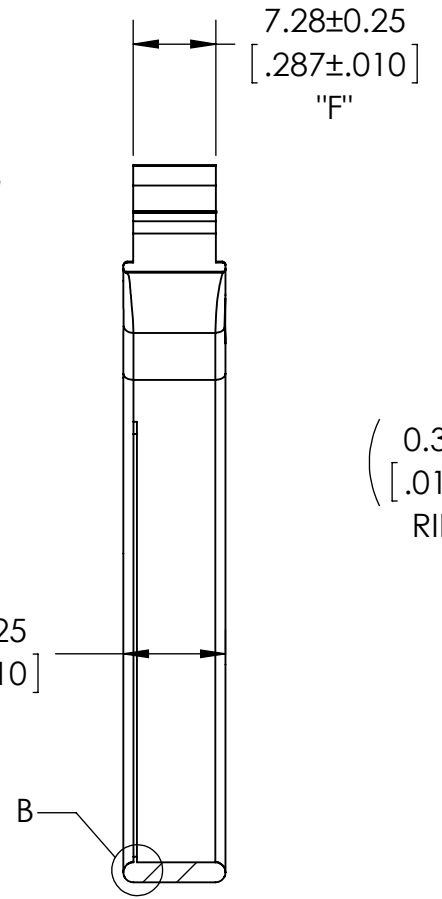
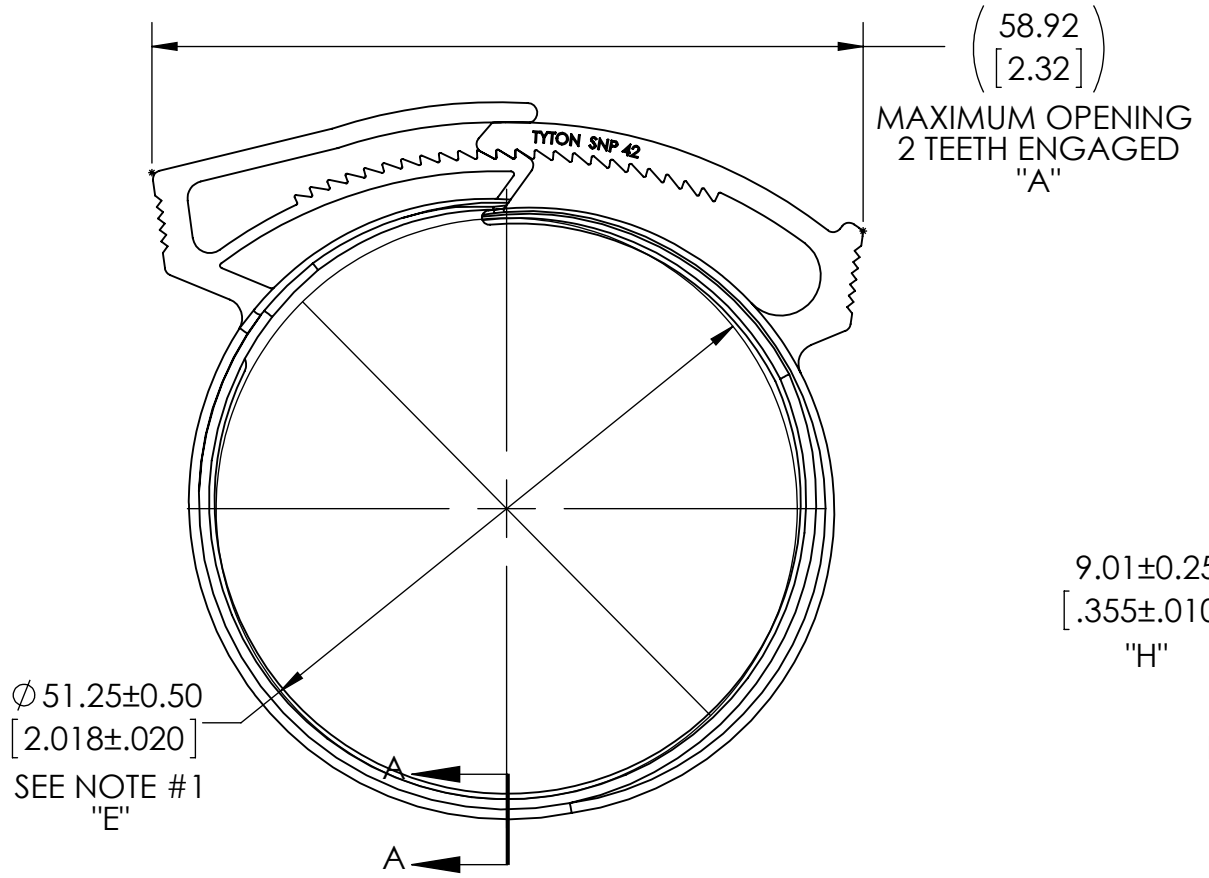
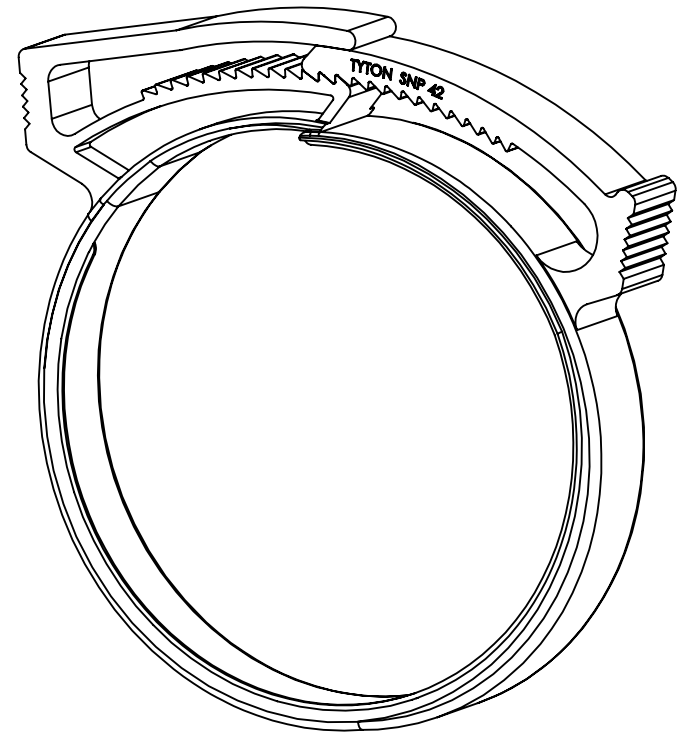
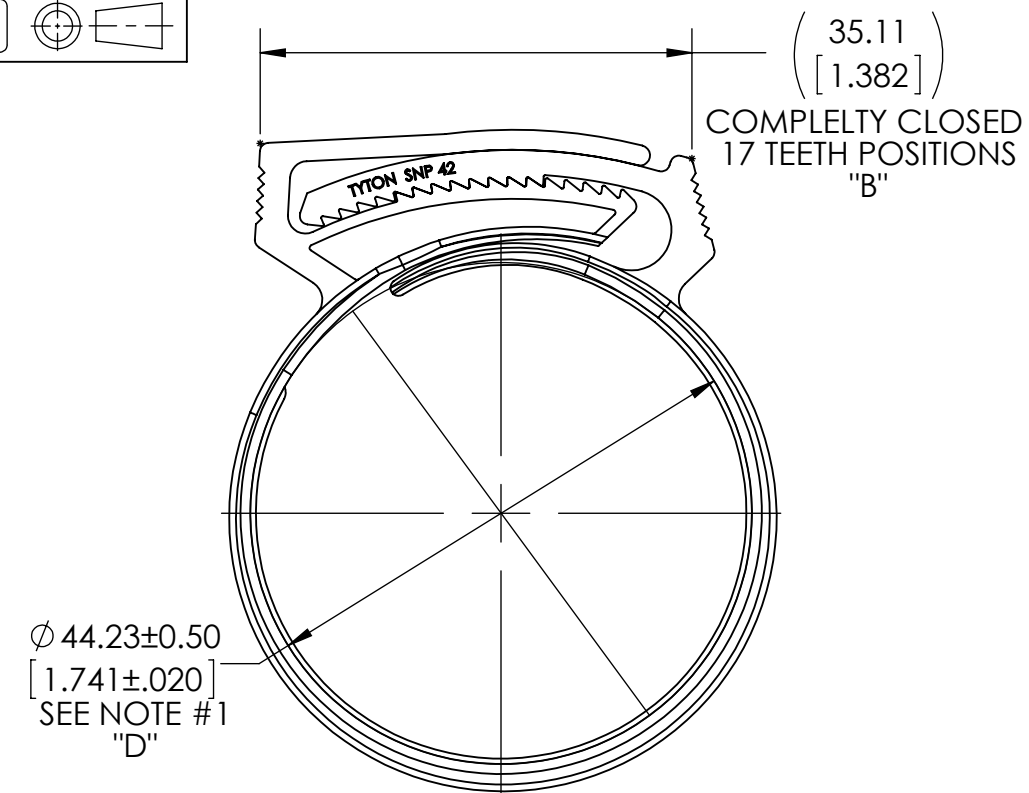

SECTION A-A

Notes  
1) INSIDE DIAMETERS ARE MEASURED IN THREE PLACES SPACED 120 DEGREES APART EXCLUDING RIB.  
2) 26 TOTAL TEETH, 17 TEETH POSITIONS.

Material  
POM (ACETAL)

Units: millimeters  
Dimension without tolerances details to:  
.xxx = ±.013  
.xx = ±.13  
.x = ±.3  
None = ±.8  
< = ±0.5°  
Dimension Formatted mm/[in]

The copyright of this drawing is reserved by HellermannTyton. It is issued on condition that it is not reproduced, copied, or disclosed to a third party, either wholly or in part, without the consent of HellermannTyton.

Drawn: CJR  
01/03/2013  
Approved: \_\_\_\_\_  
**HellermannTyton**  
North America  
Email: corp@htamericas.com  
Web: www.hellermann.tyton.com

Article/Type-No: SNP42  
Title: SNAPPER 42 - HOSE CLAMP  
Drawing-No: 13-0201-002-CSU  
Concept : Phase

Scale: 1.5:1  
Project Number: PRP13-0201  
Format: B  
Sheet: 1/1