

SERPAC 171Ri4AA (exploded isometric)

Electronic Enclosures

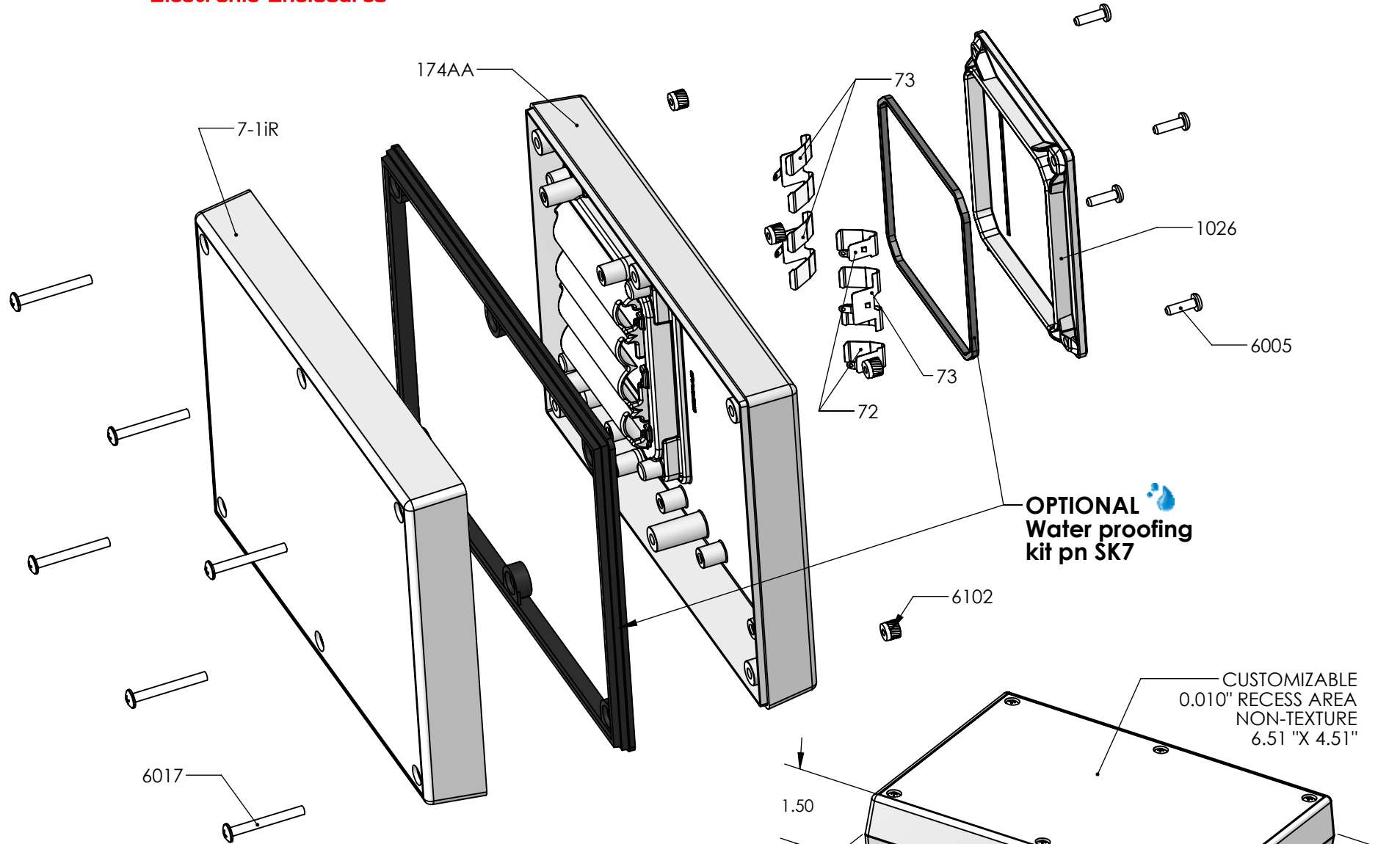

PART NO.	DESCRIPTION (Included)	ACCESSORIES (Optional)
7-1iR	Top	
174AA	4AA Bottom	
1026	Access Door	
6005	#4X3/8" Self-Tapping Screw (4)	
6017	4-40 X 1" Screw (6)	
6102	4-40 Threaded Insert (6)	
73	Double Battery Contact (3)	
72	Single Battery Contact (2)	
		PART NO. DESCRIPTION
		50 Non-skid Feet
		SK7 Seal Kit for 17X

- Notes:
- 1) Enclosure weight .47 lb / 216 g
 - 2) When used with SK7 the enclosure meets or exceeds IP 67 and NEMA 4X, 12 and 13 MIL-STD-810G 506.5 (.03 lb / 14g)
 - 3) Circuit Board drawings see sheet 3.
 - 4) All components are RoHS Compliant.

ALL DIMENSIONS ARE ± .010" 9/7/2021 (1 of 3)
 2009 Wright Ave. La Verne, CA 91750
 Ph. (626) 331-0517 Fx. (626) 331-8584 serpac.com

SERPAC 171Ri4AA

Electronic Enclosures

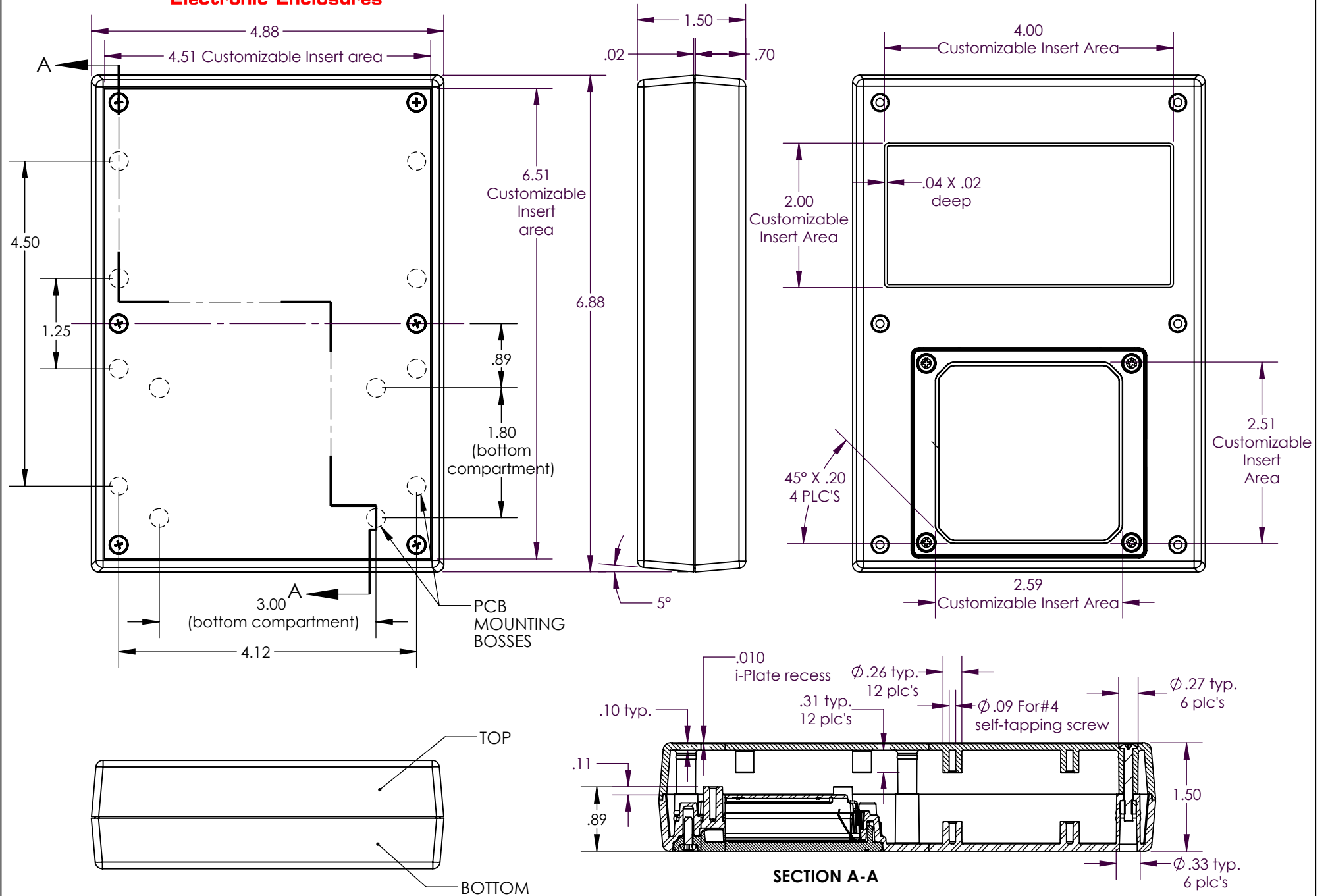

SERPAC PCB for 17X compartment enclosures

Electronic Enclosures

CIRCUIT BOARD FOR TOP

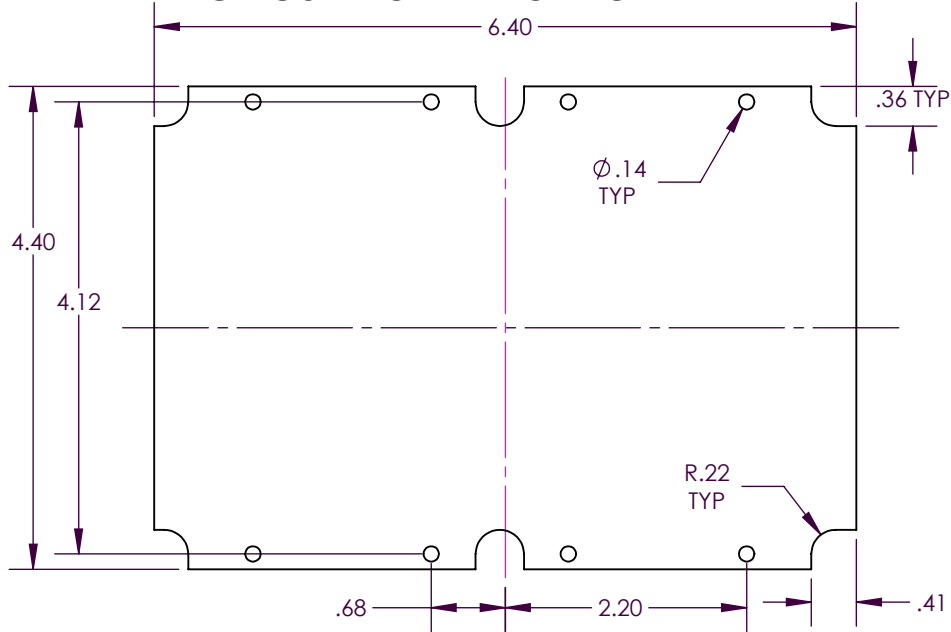

CIRCUIT BOARD FOR BOTTOM

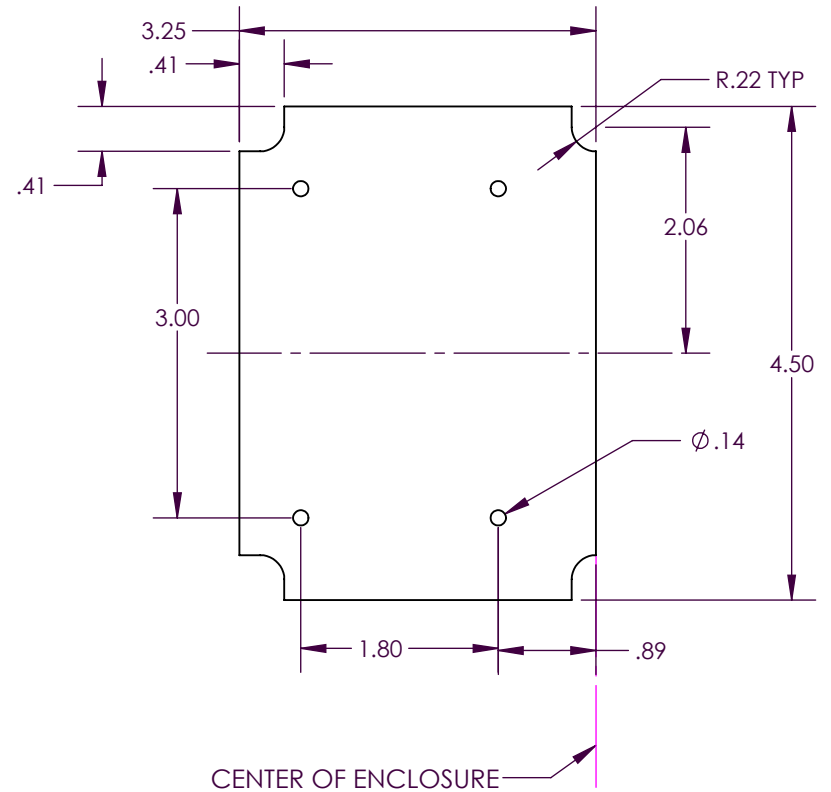

SMALL CIRCUIT BOARD FOR BOTTOM

