

CD74HC377, CD74HCT377

High Speed CMOS Logic Octal D-Type Flip-Flop with Data Enable

September 1997

Features

- Buffered Common Clock
- Buffered Inputs
- Typical Propagation Delay = 17ns at $C_L = 15\text{pF}$, $V_{CC} = 5\text{V}$, $T_A = 25^\circ\text{C}$
- Fanout (Over Temperature Range)
 - Standard Outputs 10 LSTTL Loads
 - Bus Driver Outputs 15 LSTTL Loads
- Wide Operating Temperature Range . . . -55°C to 125°C
- Balanced Propagation Delay and Transition Times
- Significant Power Reduction Compared to LSTTL Logic ICs
- HC Types
 - 2V to 6V Operation
 - High Noise Immunity: $N_{IL} = 30\%$, $N_{IH} = 30\%$ of V_{CC} at $V_{CC} = 5\text{V}$
- HCT Types
 - 4.5V to 5.5V Operation
 - Direct LSTTL Input Logic Compatibility, $V_{IL} = 0.8\text{V}$ (Max), $V_{IH} = 2\text{V}$ (Min)
 - CMOS Input Compatibility, $I_I \leq 1\mu\text{A}$ at V_{OL} , V_{OH}

Description

The Harris CD74HC377 and CD74HCT377 are octal D-type flip-flops with a buffered clock (CP) common to all eight flip-flops. All the flip-flops are loaded simultaneously on the positive edge of the clock (CP) when the Data Enable (\bar{E}) is Low.

Ordering Information

PART NUMBER	TEMP. RANGE ($^\circ\text{C}$)	PACKAGE	PKG. NO.
CD74HC377E	-55 to 125	20 Ld PDIP	E20.3
CD74HCT377E	-55 to 125	20 Ld PDIP	E20.3
CD74HC377M	-55 to 125	20 Ld SOIC	M20.3
CD74HCT377M	-55 to 125	20 Ld SOIC	M20.3

NOTES:

1. When ordering, use the entire part number. Add the suffix 96 to obtain the variant in the tape and reel.
2. Wafer or die for this part number is available which meets all electrical specifications. Please contact your local sales office or Harris customer service for ordering information.

Pinout

CD74HC377, CD74HCT377
(PDIP, SOIC)
TOP VIEW

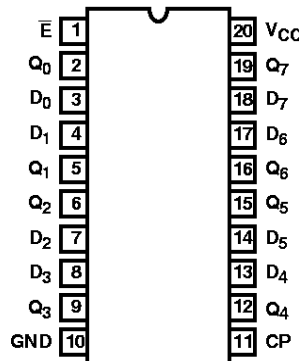

CD74HC377, CD74HCT377

Functional Diagram

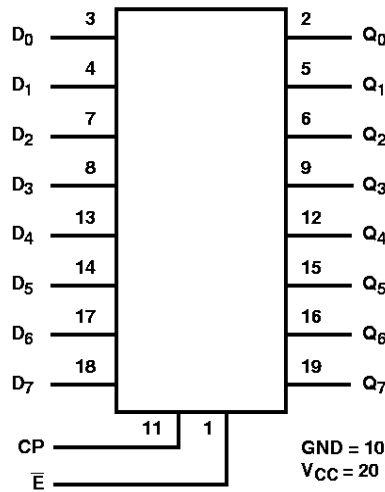

TRUTH TABLE

OPERATING MODE	INPUTS			OUTPUTS
	CP	E-bar	D _n	Q _n
Load "1"	↑	l	h	H
Load "0"	↑	l	l	L
Hold (Do Nothing)	↑	h	X	No Change
	X	H	X	No Change

NOTES:

- H = High Voltage Level Steady State.
- h = High Voltage Level One Set-up Time Prior to the Low to High Clock Transition.
- L = Low Voltage Level Steady State.
- l = Low Voltage Level One Set-up Time Prior to the Low to High Clock Transition.
- X = Don't Care.
- ↑ = Low to High Clock Transition.

Logic Diagram

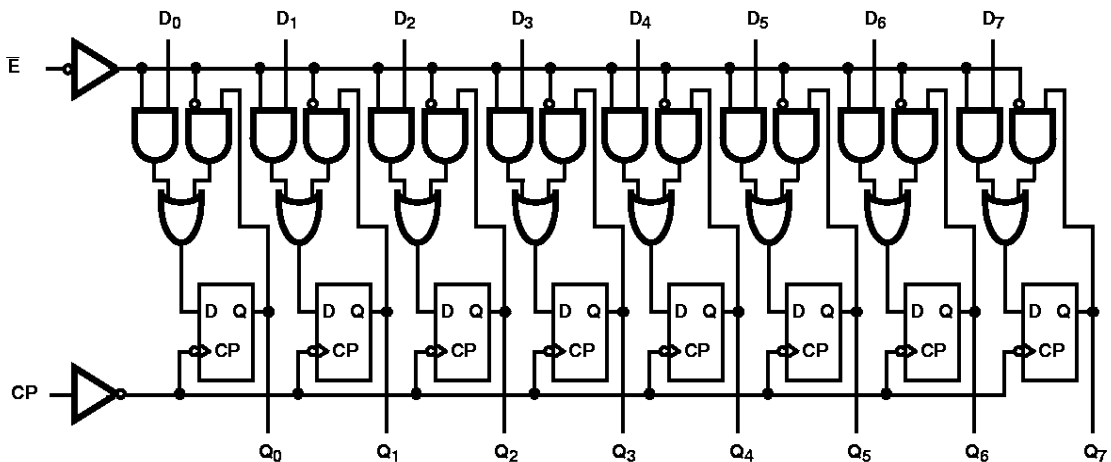

CD74HC377, CD74HCT377

Absolute Maximum Ratings

DC Supply Voltage, V_{CC}	-0.5V to 7V
DC Input Diode Current, I_{IK}	
For $V_I < -0.5V$ or $V_I > V_{CC} + 0.5V$	$\pm 20mA$
DC Output Diode Current, I_{OK}	
For $V_O < -0.5V$ or $V_O > V_{CC} + 0.5V$	$\pm 20mA$
DC Output Source or Sink Current per Output Pin, I_O	
For $V_O > -0.5V$ or $V_O < V_{CC} + 0.5V$	$\pm 25mA$
DC V_{CC} or Ground Current, I_{CC} or I_{GND}	$\pm 50mA$

Thermal Information

Thermal Resistance (Typical, Note 3)	θ_{JA} ($^{\circ}C/W$)
PDIP Package	125
SOIC Package	100
Maximum Junction Temperature	$150^{\circ}C$
Maximum Storage Temperature Range	$-65^{\circ}C$ to $150^{\circ}C$
Maximum Lead Temperature (Soldering 10s)	$300^{\circ}C$ (SOIC - Lead Tips Only)

Operating Conditions

Temperature Range (T_A)	$-55^{\circ}C$ to $125^{\circ}C$
Supply Voltage Range, V_{CC}	
HC Types	2V to 6V
HCT Types	4.5V to 5.5V
DC Input or Output Voltage, V_I , V_O	0V to V_{CC}
Input Rise and Fall Time	
2V	1000ns (Max)
4.5V	500ns (Max)
6V	400ns (Max)

CAUTION: Stresses above those listed in "Absolute Maximum Ratings" may cause permanent damage to the device. This is a stress only rating and operation of the device at these or any other conditions above those indicated in the operational sections of this specification is not implied.

NOTE:

- θ_{JA} is measured with the component mounted on an evaluation PC board in free air.

DC Electrical Specifications

PARAMETER	SYMBOL	TEST CONDITIONS		V_{CC} (V)	25°C			-40°C TO 85°C		-55°C TO 125°C		UNITS
		V_I (V)	I_O (mA)		MIN	TYP	MAX	MIN	MAX	MIN	MAX	
HC TYPES												
High Level Input Voltage	V_{IH}	-	-	2	1.5	-	-	1.5	-	1.5	-	V
				4.5	3.15	-	-	3.15	-	3.15	-	V
				6	4.2	-	-	4.2	-	4.2	-	V
Low Level Input Voltage	V_{IL}	-	-	2	-	-	0.5	-	0.5	-	0.5	V
				4.5	-	-	1.35	-	1.35	-	1.35	V
				6	-	-	1.8	-	1.8	-	1.8	V
High Level Output Voltage CMOS Loads	V_{OH}	V_{IH} or V_{IL}	-0.02	2	1.9	-	-	1.9	-	1.9	-	V
			-0.02	4.5	4.4	-	-	4.4	-	4.4	-	V
			-0.02	6	5.9	-	-	5.9	-	5.9	-	V
High Level Output Voltage TTL Loads	V_{OH}	V_{IH} or V_{IL}	-	-	-	-	-	-	-	-	-	V
			-4	4.5	3.98	-	-	3.84	-	3.7	-	V
			-5.2	6	5.48	-	-	5.34	-	5.2	-	V
Low Level Output Voltage CMOS Loads	V_{OL}	V_{IH} or V_{IL}	0.02	2	-	-	0.1	-	0.1	-	0.1	V
			0.02	4.5	-	-	0.1	-	0.1	-	0.1	V
			0.02	6	-	-	0.1	-	0.1	-	0.1	V
Low Level Output Voltage TTL Loads	V_{OL}	V_{IH} or V_{IL}	-	-	-	-	-	-	-	-	-	V
			4	4.5	-	-	0.26	-	0.33	-	0.4	V
			5.2	6	-	-	0.26	-	0.33	-	0.4	V
Input Leakage Current	I_I	V_{CC} or GND	-	6	-	-	± 0.1	-	± 1	-	± 1	μA
Quiescent Device Current	I_{CC}	V_{CC} or GND	0	6	-	-	8	-	80	-	160	μA

CD74HC377, CD74HCT377

DC Electrical Specifications (Continued)

PARAMETER	SYMBOL	TEST CONDITIONS		V _{CC} (V)	25°C			-40°C TO 85°C		-55°C TO 125°C		UNITS
		V _I (V)	I _O (mA)		MIN	TYP	MAX	MIN	MAX	MIN	MAX	
HCT TYPES												
High Level Input Voltage	V _{IH}	-	-	4.5 to 5.5	2	-	-	2	-	2	-	V
Low Level Input Voltage	V _{IL}	-	-	4.5 to 5.5	-	-	0.8	-	0.8	-	0.8	V
High Level Output Voltage CMOS Loads	V _{OH}	V _{IH} or V _{IL}	-0.02	4.5	4.4	-	-	4.4	-	4.4	-	V
High Level Output Voltage TTL Loads			-4	4.5	3.98	-	-	3.84	-	3.7	-	V
Low Level Output Voltage CMOS Loads	V _{OL}	V _{IH} or V _{IL}	0.02	4.5	-	-	0.1	-	0.1	-	0.1	V
Low Level Output Voltage TTL Loads			4	4.5	-	-	0.26	-	0.33	-	0.4	V
Input Leakage Current	I _I	V _{CC} and GND	0	5.5	-	-	±0.1	-	±1	-	±1	μA
Quiescent Device Current	I _{CC}	V _{CC} or GND	0	5.5	-	-	8	-	80	-	160	μA
Additional Quiescent Device Current Per Input Pin: 1 Unit Load	ΔI _{CC}	V _{CC} -2.1	-	4.5 to 5.5	-	100	360	-	450	-	490	μA

NOTE: For dual-supply systems theoretical worst case (V_I = 2.4V, V_{CC} = 5.5V) specification is 1.8mA.

HCT Input Loading Table

INPUT	UNIT LOADS
\bar{E}	1.5
CP	0.5
All D _n Inputs	0.25

NOTE: Unit Load is ΔI_{CC} limit specified in DC Electrical Table, e.g., 360μA max at 25°C.

Prerequisite for Switching Specifications

PARAMETER	SYMBOL	TEST CONDITIONS	V _{CC} (V)	25°C			-40°C TO 85°C		-55°C TO 125°C		UNITS
				MIN	TYP	MAX	MIN	MAX	MIN	MAX	
HC TYPES											
Maximum Clock Frequency	f _{MAX}	-	2	6	-	-	5	-	4	-	MHz
			4.5	30	-	-	25	-	20	-	MHz
			6	35	-	-	29	-	23	-	MHz
Clock Pulse Width	t _W	-	2	80	-	-	100	-	120	-	ns
			4.5	16	-	-	20	-	24	-	ns
			6	14	-	-	17	-	20	-	ns

CD74HC377, CD74HCT377

Prerequisite for Switching Specifications (Continued)

PARAMETER	SYMBOL	TEST CONDITIONS	V _{CC} (V)	25°C			-40°C TO 85°C		-55°C TO 125°C		UNITS
				MIN	TYP	MAX	MIN	MAX	MIN	MAX	
Set-up Time, \bar{E} , Data to CP	t _{SU}	-	2	60	-	-	75	-	90	-	ns
			4.5	12	-	-	15	-	18	-	ns
			6	10	-	-	13	-	15	-	ns
Hold Time, Data to CP	t _H	-	2	3	-	-	3	-	3	-	ns
			4.5	3	-	-	3	-	3	-	ns
			6	3	-	-	3	-	3	-	ns
Hold Time, \bar{E} to CP	t _H	-	2	5	-	-	5	-	5	-	ns
			4.5	5	-	-	5	-	5	-	ns
			6	5	-	-	5	-	5	-	ns
HCT TYPES											
Maximum Clock Frequency	f _{MAX}	-	4.5	25	-	-	20	-	16	-	MHz
Clock Pulse Width	t _W	-	4.5	20	-	-	25	-	30	-	ns
Set-up, Time \bar{E} , Data to CP	t _{SU}	-	4.5	12	-	-	15	-	18	-	ns
Hold Time, Data to CP	t _H	-	4.5	3	-	-	3	-	3	-	ns
Hold Time, \bar{E} to CP	t _H	-	4.5	5	-	-	5	-	5	-	ns

Switching Specifications Input t_r, t_f = 6ns

PARAMETER	SYMBOL	TEST CONDITIONS	V _{CC} (V)	25°C			-40°C TO 85°C		-55°C TO 125°C		UNITS
				MIN	TYP	MAX	MIN	MAX	MIN	MAX	
HC TYPES											
Propagation Delay (Figure 1) CP to Q	t _{PLH} , t _{PHL}	C _L = 50pF	2	-	-	175	-	220	-	265	ns
			4.5	-	-	35	-	44	-	53	ns
		C _L = 15pF	5	-	14	-	-	-	-	-	ns
			6	-	-	30	-	37	-	45	ns
Output Transition Time (Figure 1)	t _{TLH} , t _{THL}	C _L = 50pF	2	-	-	75	-	95	-	110	ns
			4.5	-	-	15	-	19	-	22	ns
			6	-	-	13	-	16	-	19	ns
Input Capacitance	C _{IN}	C _L = 50pF	-	-	-	10	-	10	-	10	pF
Maximum Clock Frequency	f _{MAX}	C _L = 15pF	5	-	60	-	-	-	-	-	MHz
Power Dissipation Capacitance (Notes 4, 5)	C _{PD}	C _L = 15pF	5	-	31	-	-	-	-	-	pF
HCT TYPES											
Propagation Delay (Figure 1) CP to Q	t _{PLH} , t _{PHL}	C _L = 50pF	4.5	-	-	38	-	48	-	57	ns
		C _L = 15pF	5	-	16	-	-	-	-	-	ns
Output Transition Time (Figure 1)	t _{TLH} , t _{THL}	C _L = 50pF	4.5	-	-	15	-	19	-	22	ns
Input Capacitance	C _{IN}	C _L = 50pF	-	-	-	10	-	10	-	10	pF

CD74HC377, CD74HCT377

Switching Specifications Input $t_r, t_f = 6\text{ns}$ (Continued)

PARAMETER	SYMBOL	TEST CONDITIONS	V_{CC} (V)	25°C			-40°C TO 85°C		-55°C TO 125°C		UNITS
				MIN	TYP	MAX	MIN	MAX	MIN	MAX	
Maximum Clock Frequency	f_{MAX}	$C_L = 15\text{pF}$	5	-	50	-	-	-	-	-	MHz
Power Dissipation Capacitance (Notes 4, 5)	C_{PD}	$C_L = 15\text{pF}$	5	-	35	-	-	-	-	-	pF

NOTES:

4. C_{PD} is used to determine the dynamic power consumption, per flip-flop.
5. $P_D = V_{CC}^2 f_i (C_{PD} + C_L)$ where f_i = Input Frequency, C_L = Output Load Capacitance, V_{CC} = Supply Voltage.

Test Circuits and Waveforms

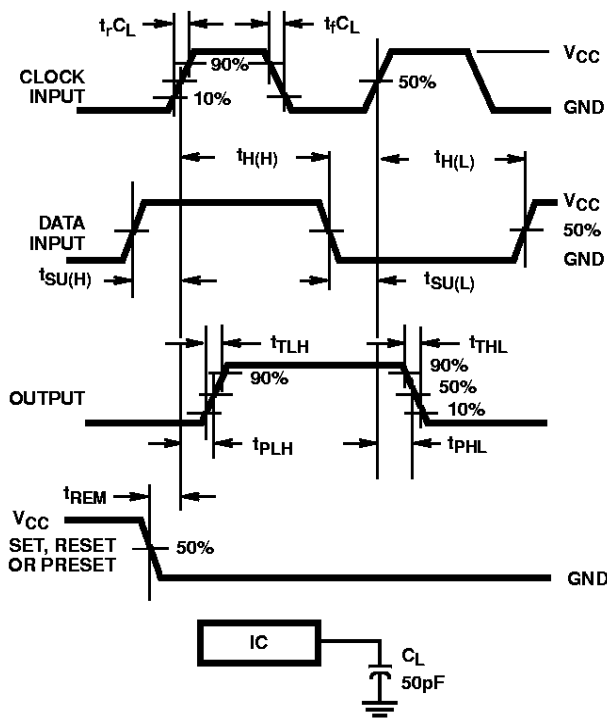

FIGURE 1. HC SETUP TIMES, HOLD TIMES, REMOVAL TIME, AND PROPAGATION DELAY TIMES FOR EDGE TRIGGERED SEQUENTIAL LOGIC CIRCUITS

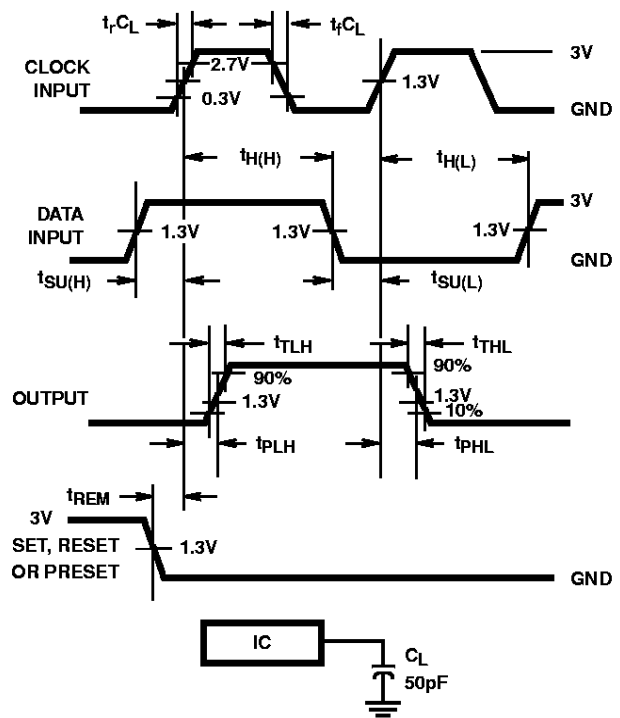

FIGURE 2. HCT SETUP TIMES, HOLD TIMES, REMOVAL TIME, AND PROPAGATION DELAY TIMES FOR EDGE TRIGGERED SEQUENTIAL LOGIC CIRCUITS