

MX7 SERIES CONNECTORS

025 Crimp Contacts, PCB-to-Cable Connectors

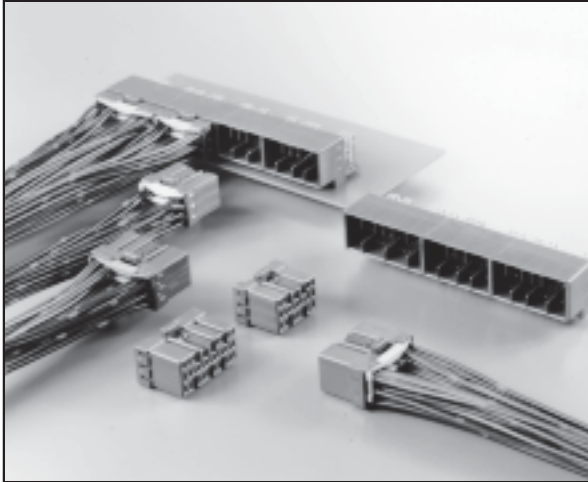

FEATURES

- Signal contacts (5 Amps) and Power contacts (7 Amps) are housed in the same connector
- Mechanical lock assures positive mating
- Double locking mechanism prevents contact from dislodging
- Several wire terminated sockets are coupled with a pin header mounted on a board
- Designed for Engine Control Unit

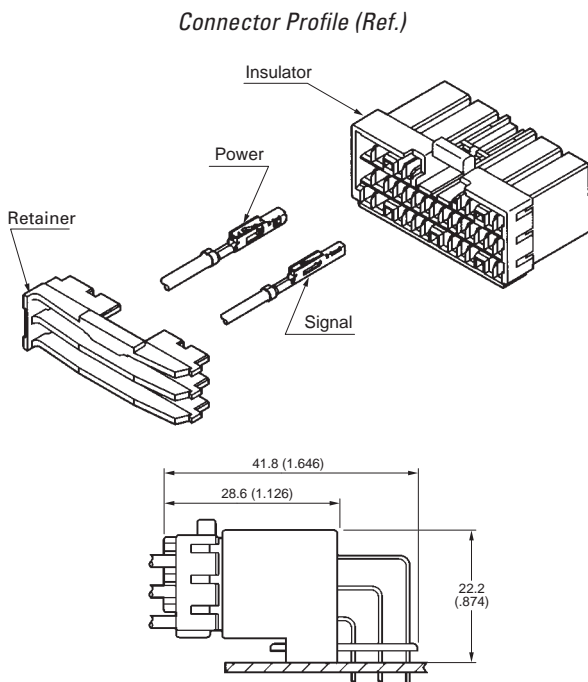

GENERAL SPECIFICATIONS

Number of Contacts	Pin: 35, 48, 93, 109, 119 Socket: 20, 26, 28, 30, 35
Contact Spacing	Signal: 2.3mm (.091") Power: 3.0mm (.118")
Current Rating	Signal: 5 Amps, Power: 7 Amps
Dielectric Withstanding Voltage	1000 VAC r.m.s. (for one minute)
Insulation Resistance	100 megohms min.
Contact Resistance	3 milliohms max.
Applicable PCB Thickness	1.6mm (.063")
Operating Temperature	-40°C to +85°C

Applicable Wire (Stranded)

Contact Type	Signal		Power
	AVS	AVSS	AVS, AVSS
Wire Type JIS			
Conductor Cross Section Area	0.3~0.5mm ²	0.3~0.85mm ²	0.5~1.25mm ²
AWG	#22-#20	#22-#18	#20-#16
Insulation Outer Diameter	ø1.4~ø2.1mm (ø.055~ø.083")		ø1.6~ø2.6mm (ø.063~ø.102")

MATERIALS AND FINISHES

Description	Materials/Finishes
Insulator	Glass-filled PBT (Dark Gray)
Socket	PBT (Dark Gray)
Locator	Glass-filled PBT (Dark Gray)
Pin Contact	High Conductive Copper Alloy/Tin Plating or Gold (Connecting points)
Socket Contact	High Conductive Copper Alloy/Tin Plating or Gold (Connecting points) with Solder (SnPb terminal area) Plating over Nickel
Retainer	Glass-filled PBT (20 Position: White, 26/35 Position: Light Blue, 28 Position: Orange, 30 Position: Green)

Note 1: Insert the number of gold plated contact for Power and Signal contacts
P*The Number of Power Contacts
S*The Number of Signal Contacts

- The above shows the general group of products. Please contact JAE Customer Service when placing an order.
- Suggested screws:
M3 tapping screws (2 or 4 grade) per JIS B1115, 1122 or 1123
- Drawing shown is for 35 positions. The stacking design varies according to the number the positions.

Dimensions and specifications subject to change without notice.



MX7 SERIES CONNECTORS

025 Crimp Contacts, PCB-to-Cable Connectors

RIGHT ANGLE PIN HEADER

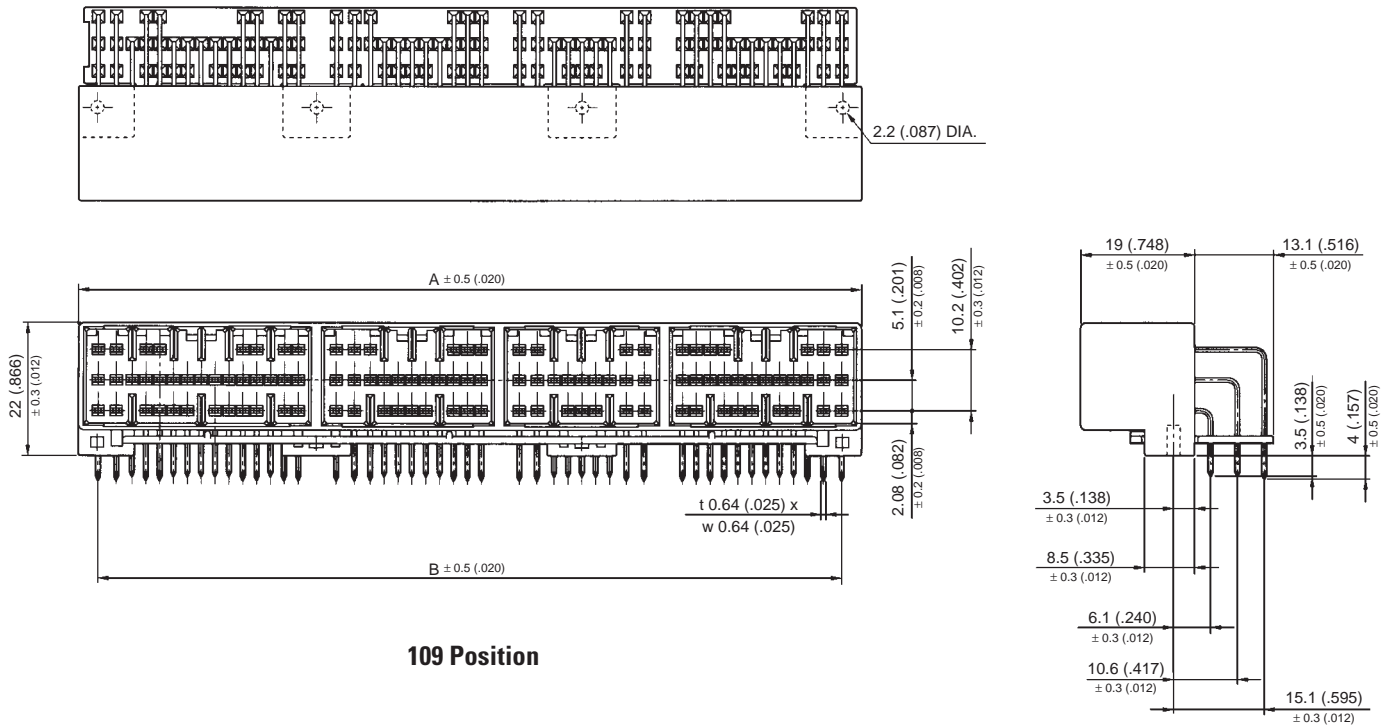

No. of Contacts	Part Number (Note 1)	Contact Position		A ±0.5 (.02)	B ±0.5 (.02)
		Signal	Power		
93	MX7- 93PL-P*S*	75	18	109 (4.29)	100.8 (3.97)
109	MX7- 109PL-P*S*	79	30	130.2 (5.13)	123.6 (4.87)
119	MX7- 119PL-P*S*	95	24	137.9 (5.43)	131.3 (5.17)

Note 1: Insert the number of gold plated contact for Power and Signal contacts
P*The Number of Power Contacts
S*The Number of Signal Contacts

Dimensions in mm (inches).

MX7 SERIES CONNECTORS

025 Crimp Contacts, PCB-to-Cable Connectors

93 Position
PCB Layout (Ref.)

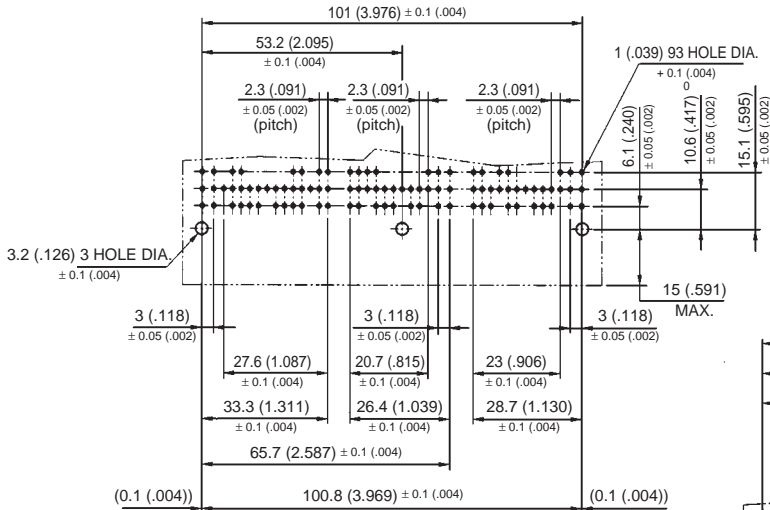

Suggested Screws:
JIS B 1115, 1122, 1123
M3 x 6 tapping screw (2 or 4 grade)

109 Position
PCB Layout (Ref.)

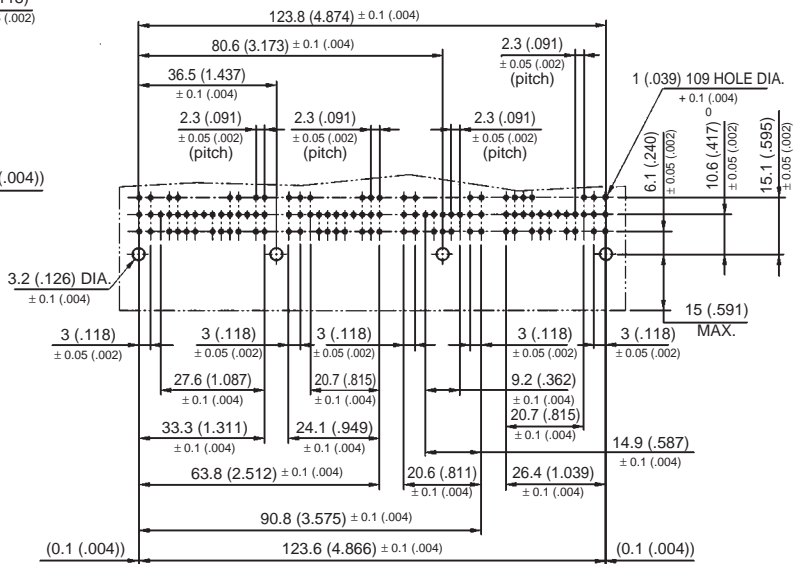

119 Position
PCB Layout (Ref.)

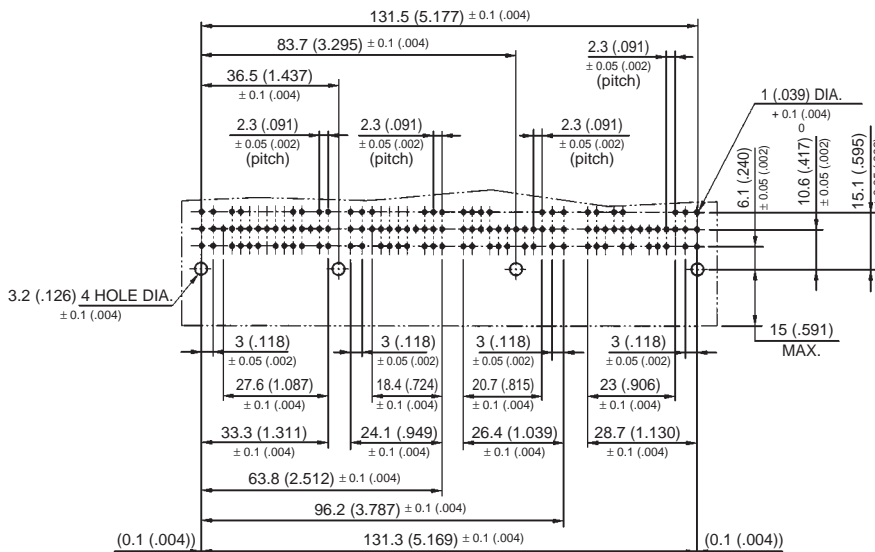

Dimensions in mm (inches).

MX7 SERIES CONNECTORS

025 Crimp Contacts, PCB-to-Cable Connectors

SOCKET HOUSING

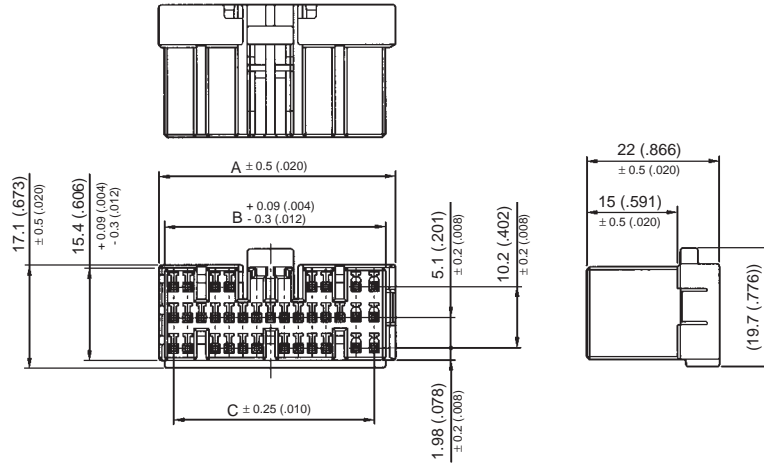

35 Position

No. of Contacts	Contact Position		Part Number	A ± 0.5 (.02)	B $+0.09$ (0.004) -0.3 (0.012)	C ± 0.25 (.010)	Retainer
	Signal	Power					
20	8	12	MX7-A-20SC	27.2 (1.07)	24.6 (0.97)	20.6 (0.81)	MX7-A-20S-RT
26	20	6	MX7-A-26SC	30.3 (1.19)	27.7 (1.09)	24.1 (0.95)	MX7-A-26S-RT
28	22	6	MX7-A-28SC	32.6 (1.28)	30 (1.18)	26.4 (1.04)	MX7-A-28S-RT
30	24	6	MX7-A-30SC	34.9 (1.37)	32.3 (1.27)	28.7 (1.13)	MX7-A-30S-RT
35	29	6	MX7-A-35SC	39.5 (1.56)	36.9 (1.45)	33.3 (1.31)	MX7-A-35S-RT

Dimensions in mm (inches).

MX7 SERIES CONNECTORS

025 Crimp Contacts, PCB-to-Cable Connectors

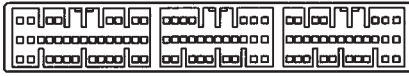
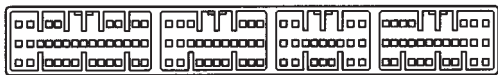
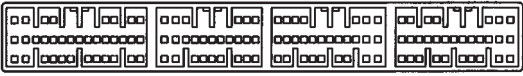
No. of Positions	Right Angle Pin Header		Socket Housing			
	Part Number		No. of Positions	Part Number	Signal	Power
93	MX7-93PL-P*S*		28	MX7-A-28SC	22	6
	(Signal: 75 Contacts, Power: 18 Contacts)		30	MX7-A-30SC	24	6
			35	MX7-A-35SC	29	6
109	MX7-109PL-P*S*		20	MX7-A-20SC	8	12
	(Signal: 79 Contacts, Power: 30 Contacts)		26	MX7-A-26SC	20	6
			28	MX7-A-28SC	22	6
			35	MX7-A-35SC	29	6
119	MX7-119PL-P*S*		26	MX7-A-26SC	20	6
	(Signal: 95 Contacts, Power: 24 Contacts)		28	MX7-A-28SC	22	6
			30	MX7-A-30SC	24	6
			35	MX7-A-35SC	29	6

Note 1: Insert the number of gold plated contact for Power and Signal contacts
 P*The Number of Power Contacts
 S*The Number of Signal Contacts

• Signal Contact (5A)

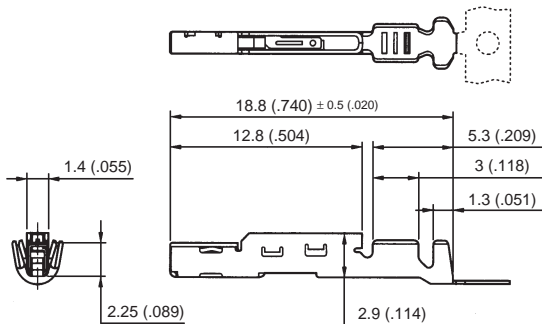

• Power Contact (7A)

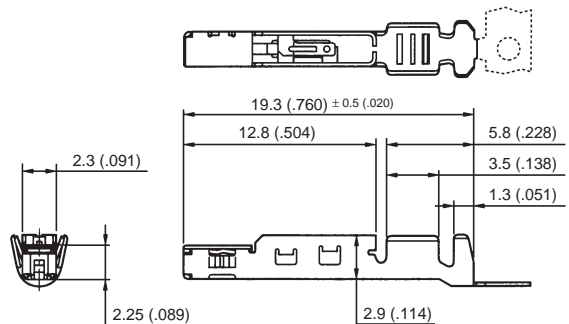

Type	Part Number (Note 1)	Finish (Note 2)	Applicable Wire Stranded				Applicable Tool	
			Type	AWG	Conductor Cross Section	Insulation Outer Dia.	Hand Crimp	Semi-Auto (CT350-2 Type)
Signal	MX7-SGC3-7000	a	AVS	#22-#20	0.3~0.5mm ² (.011~.020)	ø 1.4~ø 2.1mm (ø .055~ø .083)	CT160-3-MX73	Applicator: 350-MX73-2 Press: CP210-1B
			AVSS	#22-#18	0.3~0.85mm ² (.011~.033)			
	MX7-SGC3-1-7000	b	AVS	#22-#20	0.3~0.5mm ² (.011~.020)			
			AVSS	#22-#18	0.3~0.85mm ² (.011~.033)			
Power	MX7-PWC2-4500	a	AVS AVSS	#20-#16	0.5~1.25mm ² (.020~.049)	ø 1.6~ø 2.6mm (ø .063~ø .102)	CT160-3-MX72	Applicator: 350-MX72-2 Press: CP210-1B

Note 1: The figures following the Part Number (-7000, -4500) indicate the Number of contacts per magazine assembly reel.

Note 2: Contact Finishes/a-Tin Plating, b-Gold Plating (connecting area) with Solder (SnPb, terminal area) Plating over Nickel.

Dimensions in mm (inches).

