

TPC-1581WP

15.6" WXGA TFT LED LCD Multi-Touch Panel Computer with 4th Gen. Intel® Core™ i3 Processor



Features

- Industrial-grade 15.6" HD TFT LCD with 50K lifetime and LED backlight
- 4th Gen Intel® Core™ i3-4010U with 4 GB DDR3L SDRAM
- 16:9 widescreen display with PCAP multi-touch
- IP66-rated front panel and panel mount
- Built-in intelligent home key and iKey for intuitive operation
- Front-facing LED indicators show operating status
- Diverse system I/O and isolated digital I/O via iDoor technology
- Supports fieldbus protocols via iDoor technology
- 3G/GPS/GPRS/Wi-Fi capabilities via iDoor technology
- Supports MRAM via iDoor technology
- Chassis grounding protection
- HDMI and audio multimedia support
- Anti-scratch surface with 7H hardness



Introduction

The TPC-1581WP features a 4th Gen Intel Core i3-4010U 1.7 GHz processor with 4 GB DDR3L SDRAM to support high-performance computing. For enhanced durability and reliability, the system's 15.6" HD TFT LCD features an anti-scratch surface with 7H hardness, 16:9 widescreen aspect ratio, and multi-touch control. With the inclusion of Advantech's iDoor technology system via the mini PCIe slot, the system can be equipped with additional I/O, isolated digital I/O, fieldbus protocols, 3G/GPS/GPRS/Wi-Fi communication, and MRAM. Moreover, the integrated HDMI and audio ports allow a secondary monitor and speakers to be attached for increased functionality.

Specifications

General

- BIOS**: AMI UEFI
- Certification**: BSMI, CCC, CE, FCC Class A, UL
- Cooling System**: Fanless design
- Dimensions (W x H x D)**: 419.7 x 269 x 56.7 mm (16.52 x 10.59 x 2.23 in)
- Enclosure**: Front bezel: Die cast aluminum alloy
Back housing: PC/ABS resin
- Mount Options**: Panel
- OS Support**: Microsoft® WES7 (32/64-bit), Windows 7 (32/64-bit), Windows Embedded 8.1 Industry Pro (64-bit), Ubuntu 14.04.2 LTS, Windows 10 IoT Enterprise LTSB
- Power Consumption**: 18W typical, 60W max. (without add-on card)
- Power Input**: 24V_{DC} ± 20%
- Watchdog Timer**: 1 ~ 255 sec (system)
- Weight (Net)**: 6 kg (13.22 lbs)

System Hardware

- CPU**: 4th Gen Intel® Core™ i3-4010U 1.7 GHz
- Chipset**: Lynx Point-LP
- Memory**: 4 GB DDR3L 1600 MHz SODIMM SDRAM
- LAN**: 2 x 10/100/1000BASE-T
- Expansion Slots**: Full-size mini PCIe
- Storage**: 1 x CFast
1 x 2.5" SATA SSD
1 x mSATA (via mini PCIe slot; cannot used simultaneously with iDoor)
- I/O**: 1 x RS-232/422/485, 1 x RS-232, 2 x USB 3.0, 1 x HDMI 1.4, 1 x Audio line out, 1 x USB 2.0 (optional), 1 x Audio mic in (optional)

LCD Display

- Display Type**: WXGA TFT LED LCD
- Display Size**: 15.6
- Max. Resolution**: 1366 x 768

- Max. Colors**: 16.7M
- Luminance**: 300 cd/m²
- Viewing Angle (H/V°)**: 170/160
- Backlight Life**: 50,000 hr
- Contrast Ratio**: 500:1

Touchscreen

- Light Transmission**: ≥88%
- Resolution**: 2048 x 2048 dot
- Type**: Projected capacitive

Environment

- Humidity**: 10 ~ 95% RH @ 40 °C, non-condensing
- Ingress Protection**: IP66-rated front panel
- Operating Temperature**: 0 ~ 55 °C (32 ~ 131 °F)
- Storage Temperature**: -20 ~ 60 °C (-4 ~ 140 °F)
- Vibration Protection**: With HDD: 1 Grms (5 ~ 500 Hz) (operating, random vibration)

Ordering Information

- TPC-1581WP-433BE**: Multi-touch panel PC with 15.6" HD display, Intel i3-4010U, 4 GB SDRAM, and iDoor

Rear View

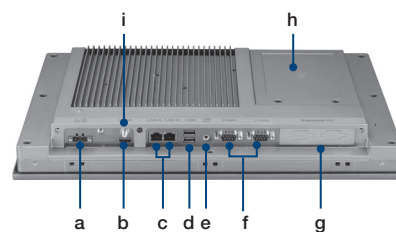

- a. 24V_{DC} power
- b. HDMI
- c. GbE
- d. USB3.0
- e. Audio line out
- f. COM port, RS-232/422/485, and RS-232
- g. Expansion I/O (iDoor)
- h. 2.5" SATA SSD, CFast, and mini PCIe slot
- i. SMA connector for antenna

Dimensions

Unit: mm [inch]

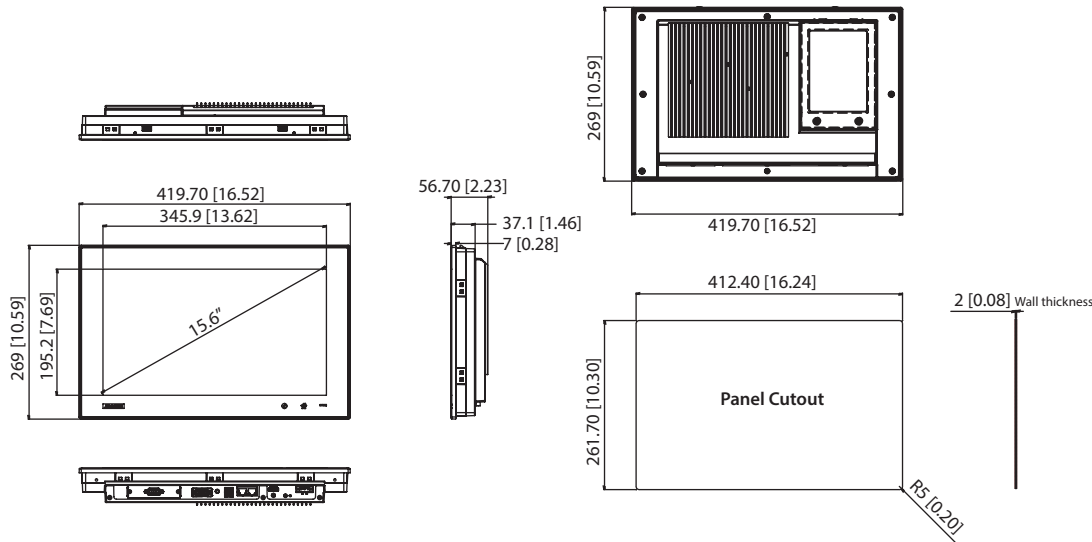

Panel Cutout Dimensions: 261.7 x 412.4 mm (10.30 x 16.24 in)

Optional Accessories

- **96PSA-A150W24T2** Adapter 100 ~ 240 V, 150W, 24 V
- **1702002600** Power cable (US) 1.8 M
- **1702002605** Power cable (EU) 1.8 M
- **1702031801** Power cable (UK) 1.8 M
- **1700000596-11** Power cable (China/Australia) 1.8 M
- **EWM-W151H01E** 802.11bgn RTL8188EE 1T1R, half-size mini PCIe (also need 9656EWMG00E)
- **9656EWMG00E** Half-size mini PCIe to full-size mini PCIe bracket set
- **1750000318** EMI antenna 2DBI 2.4GHz SMA CONN for ARK-3384
- **1750003222** 802.11b/g 5dBi dipole antenna
- **1750003418** Wireless antenna AN2400-5901RS R/P SMA.M9dB

Embedded OS

- **2070013487** TPC-xx81WP WS7P x64 MUI image v4.12 B003
- **2070013889** TPC-xx81WP WS7P x86 MUI image v4.13
- **2070014320** TPC-1881WR WS7P X64 MUI image V4.14
- **2070014920** TPC-1881WP-433AE WIN10ENT LTSB image
- **2070014921** TPC-1881WP-473AE WIN10ENT LTSB image

S/W Bundle Offering

- **WA-CT1581W-3RHE5AE** TPC-1581WP-433AE with Control Runtime & Visualization, 128 G SSD, 2 MB MRAM, and WES7P

iDoor Modules

- **PCM-24D2R4-AE** 2-port isolated RS-422/485 mPCIe, DB9
- **PCM-27D24DI-AE** 24-channel isolated digital I/O w/ counter mPCIe, DB37
- **PCM-26D2CA-AE** 2-port isolated CAN bus mPCIe, CANopen, DB9
- **PCM-24R1TP-AE** 1-Port Gigabit Ethernet, Intel® 82574L, mPCIe, RJ45
- **PCM-24S2WF-AE** Wi-Fi 802.11 a/b/g/n 2T2R w/Bluetooth 4.0, half-size mPCIe, 2-port SMA
- **PCM-26D1DB-MAE** 1-port Hilscher netX100 fieldbus mPCIe, PROFIBUS, DB9, Master
- **PCM-26R2PN-MAE** 2-port Hilscher netX100 fieldbus mPCIe, PROFINET, RJ45, Master
- **PCM-26R2EC-MAE** 2-port Hilscher netX100 fieldbus mPCIe, EtherCAT, RJ45, Master
- **PCM-26R2EI-MAE** 2-port Hilscher netX100 fieldbus mPCIe, EtherNet/IP, RJ45, Master
- **PCM-26R2S3-MAE** 2-port Hilscher netX100 fieldbus mPCIe, Sercos III, RJ45, Master

Application Software

<p>WebAccess/SCADA</p>	<p>Advantech WebAccess/SCADA is a 100% browser-based IIoT software platform aimed at supervisory control and data acquisition (SCADA) operations. WebAccess/SCADA provides open interfaces that allow our customers and partners to develop unique IoT applications for different vertical markets. In addition to supporting traditional SCADA functions, the platform features an HTML5-based user interface and intelligent dashboard to facilitate cross-platform, cross-browser data analysis. Moreover, WebAccess/SCADA not only offers built-in widgets, but is also equipped with an innovative Widget Builder that enables customers to build their own widgets.</p>
<p>WebAccess/HMI</p>	<p>Advantech WebAccess/HMI is human-machine interface (HMI) software based on Microsoft's Windows operating system. This software features excellent communication and monitoring capabilities, supports more than 350 PLC communication protocols, and offers a wide choice of screen design objects to satisfy diverse integrations of factory automation and HMI operation and monitoring requirements.</p>
	<p>The CODESYS application-ready-package offering includes a PC-based panel controller with multi-touch control, high-performance Intel Core i multi-core processor, SSD, 2 MB MRAM, Microsoft Windows Embedded 7 Pro OS, and CODESYS Control Runtime & Visualization software. This package allows users to easily develop a PC-based real-time control system, enables real-time PLC or PLC/SoftMotion control with flexible fieldbus options such as PROFINET, EtherCAT, EtherNet/IP, CANopen, and Modbus TCP/RTU, and facilitates on-site visualized HMI operation. The software/hardware flexibility and the stability of a PC-based cabinet controller are suitable for various control applications in vertical industries.</p>

Please note: If some optional modules are offered with the system, additional system certificates may be required in certain regions/countries. Please contact Advantech for certificate compliance.