



RFM Integrated Device, Inc.

PRODUCT SPECIFICATION

Part Number: ANT1014
71.1x71.1x6.6mm

Antenna, Patch

865 MHz ~867MHz

BW
14MHz min (Without PCB)

15MHz min (With PCB)

Gain @ Zenith, dBi +1.0

1. SCOPE

This specification covers the dielectric antenna for RFID.

2. Name of the product

This product is named "Dielectric Antenna" .



3. Electrical characteristics

3-1 Electrical characteristics of antenna

The antenna has the electrical characteristics given in Table 1 under the manufacturer's standard installation conditions shown in the figure in Appendix

Table 1

No	Parameter	Specification	Notes
1	Range Of Receiving Frequency	865 MHz ~867MHz	
2	Center Frequency (Without PCB)	865MHz \pm 3MHz	With 109.75 \times 120.90 mm GND Plane
3	Bandwidth (Without PCB)	14MHz min	Return Loss@-10dB
4	Center Frequency (With PCB)	868MHz \pm 3MHz	With 102.1 \times 98.8 mm GND Plane
5	Bandwidth (With PCB)	15 MHz min	Return Loss@-10dB
6	VSWR	1.5 max	Center Frequency
7	Gain at Zenith	+1.0 dBi typ.	
8	Gain at 10° Elevation	-5.0 dBi typ.	
9	Axial Ratio	5 typ.	
10	Polarization	RHCP	Right Hand Circular Polarization
11	Impedance	50 Ohm	
12	Frequency Temperature Coefficient (τ_f)	-40°C to +105°C	0 \pm 20ppm / °C
13	Operating Temperature	-40°C to +105°C	

4. Environmental conditions

4-1 Operating conditions

The antenna has the electrical characteristics given in Tables 1 in the temperature range of -40°C to $+105^{\circ}\text{C}$ and under the environmental conditions of $+40^{\circ}\text{C}$ and 0-95% r.h.

4-2 Storage temperature range

The storage temperature range of product is -40°C to $+105^{\circ}\text{C}$

4-3 Feed pin temperature range

Maximum temperature for soldering of feed pin is $+290^{\circ}\text{C}$ for 3 second.

5. Reliability tests

5-1. Low-temperature test

Expose the specimen to -45°C for 400 hours and then to normal temperature/humidity for 24 hours or more. After this test, examine its appearance and functions.

5-2 High-temperature test

Expose the specimen to $+105^{\circ}\text{C}$ for 400 hours and then to normal temperature/humidity for 24 hours or more. After this test, examine its appearance and functions.

5-3 High-temperature/high-humidity test

Subject the object to the environmental conditions of $+60^{\circ}\text{C}$ and 90-95% r.h. for 96 hours, then expose to normal temperature/humidity for 24 hours or more. After this test, examine its appearance and functions.

5-4 Thermal shock test

Subject the object to cyclic temperature change (-40°C , 2 hours \Leftrightarrow $+85^{\circ}\text{C}$, 2 hours) for 100 cycles, the expose to normal temperature/humidity for 24 hours or more.

5-5 Vibration test

5-5-1 Sinusoidal vibration test

Subject the object to vibrations of 5 to 200 to 5Hz swept in 10 minutes, 4.5G at maximum (2mm amplitude), in X and Y directions for two hours each and in Z direction for four hours. After this test, examine its appearance functions.

5-5-2 Vibration test in packaged condition

Subject the object, which is packaged as illustrated, to vibrations of 15 to 60 to 15Hz swept in 6 minutes, 4G at maximum (2mm amplitude at maximum), applied in X, Y and Z directions for two hours each, i.e. six hours in total. After this test, examine its appearance and functions.

5-6 Free fall test in packaged condition

Drop the object, which is packaged as illustrated, to a concrete surface from the height of 90 cm, on one corner, three edges and six faces once each, i.e. 10 times in total. After this test, examine its appearance and functions.

6. Inspection

As for the examination during mass production, we place the antenna in the production fixture individually, using the network analyzer to compare its central frequency, bandwidth, and return loss with that of the golden sample.

7. Test Record

A Copy of test record filled with following contents shall be provided at time of delivery.

7-1 Quantity of delivery

7-2 Measurement of electrical characteristics

Following data at normal temperature obtained by the method described in section 18.

7-3 Temperature and humidity of test

Quantity for sampling inspection shall be $n=5$ for any lot. In case quantity per lot is less than 5, the whole lot shall be inspected.

8. Warranty

If any defect occurs from the product during proper use within a year after delivery, it will be repaired or replaced free of charge.

9. Other

Any question arising from this specification manual shall be solved by arrangement made by both parties.

10. Precautions for use

Antenna pattern use a silver electrode.

Please don't use the corrosion gas (sulfur gas, chlorine gas) in the atmosphere.

Please don't direct solder onto the silver electrode of Antenna pattern.

11. Drawings

Shape and Dimension

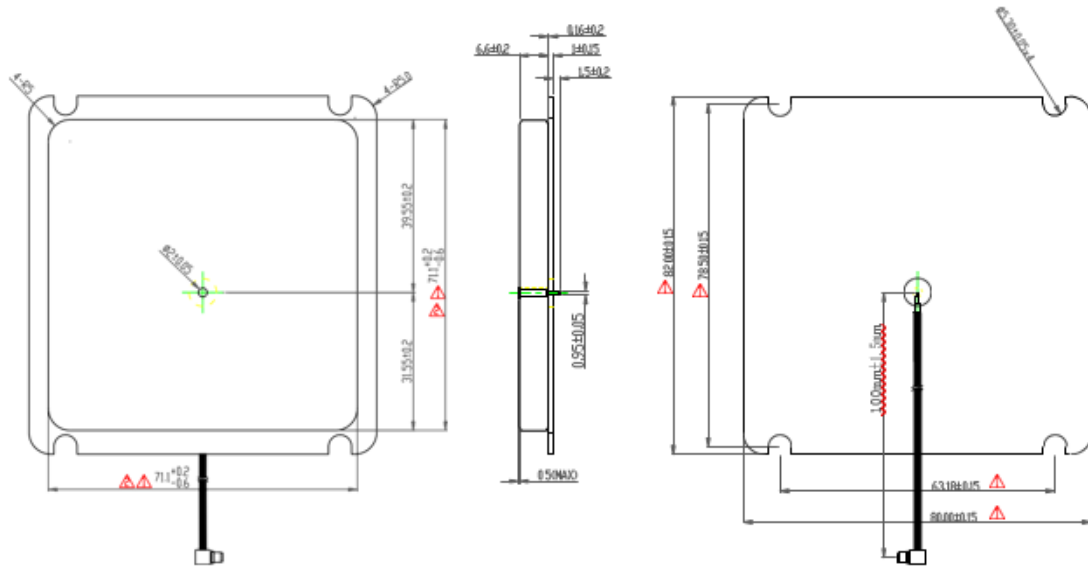

12. Typical Electrical Characteristics (T=25°C)

Return Loss, SWR, Impedance, measured on the test fixture.

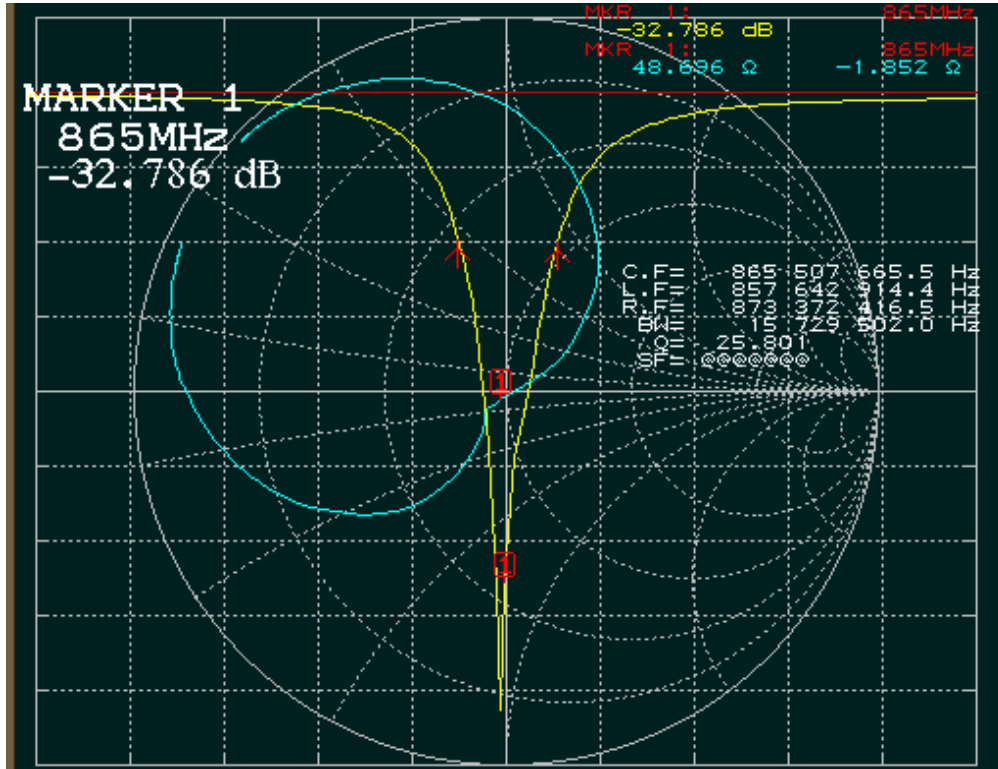

S11 Return Loss Measurement in free space

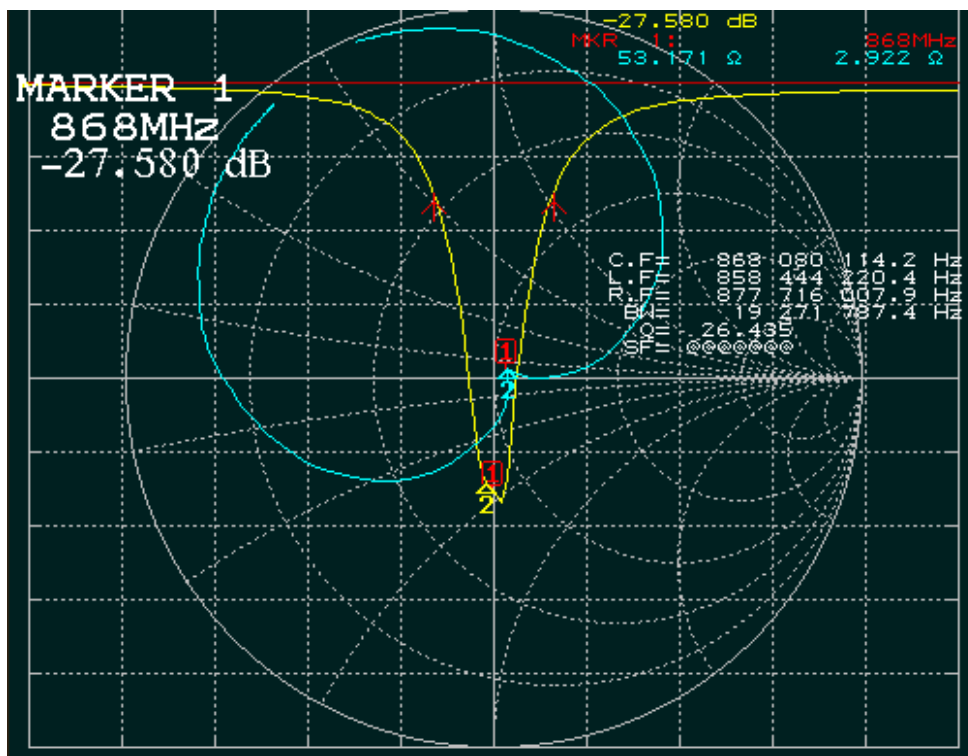

S11 Return Loss With PCB Board On GND Plane

13. Tape Dimension

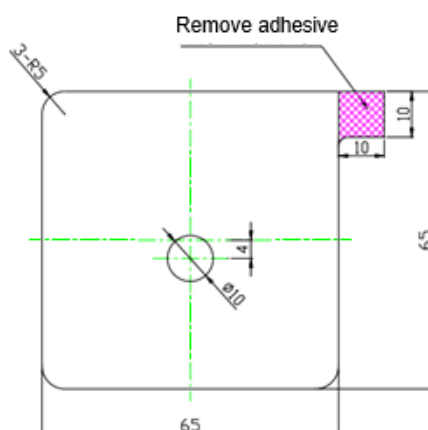

1. NITTO No. 5000NS
2. Double coated adhesive
3. Thickness: 0.16mm
4. Adhesive is in the up side.
5. All tolerance is $\pm 0.2\text{mm}$

14. Marking

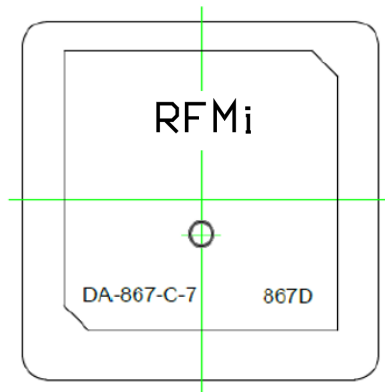

15. PCB

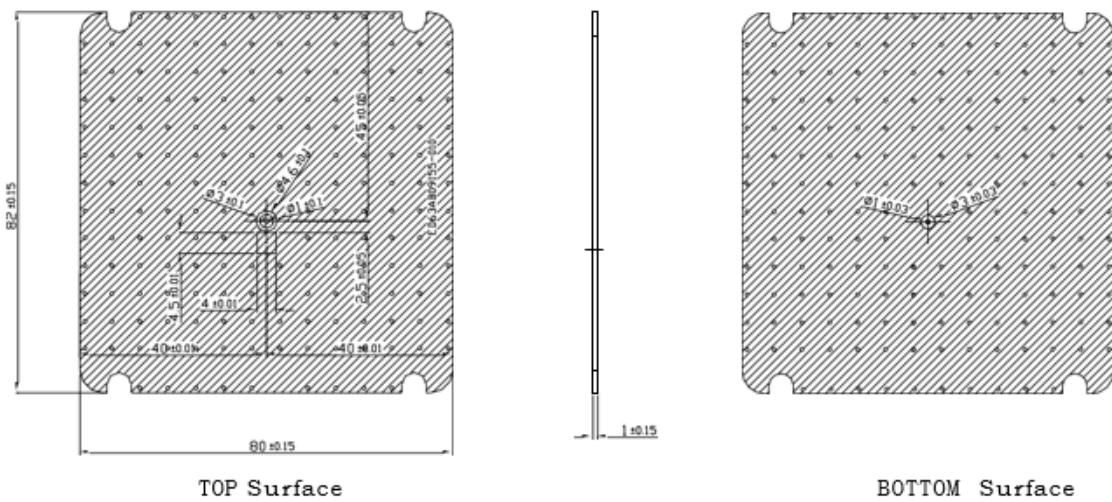

16. Cable

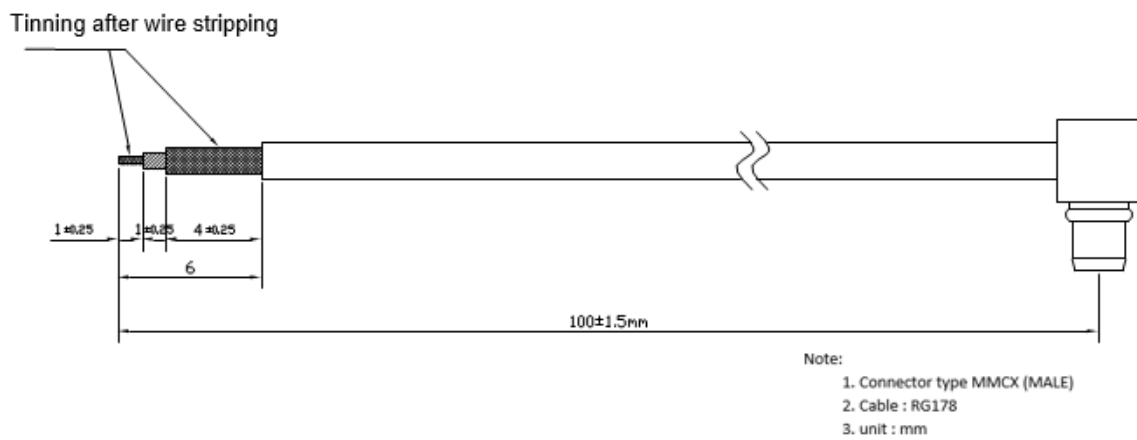

17. Test Jig and Dimension (Without PCB)

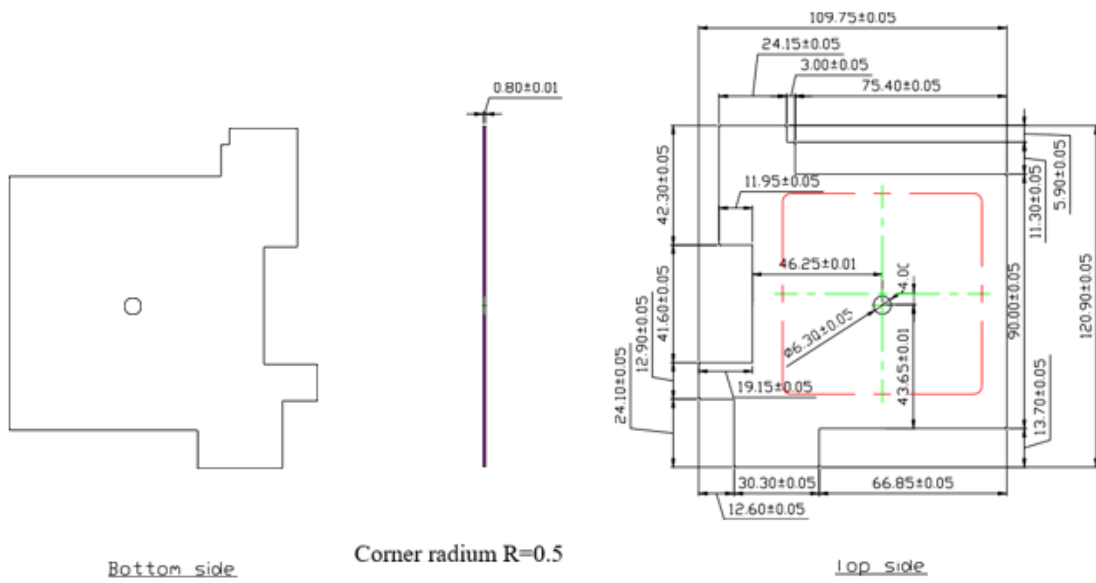

18. Test Fixture Antenna Setup & Measurements

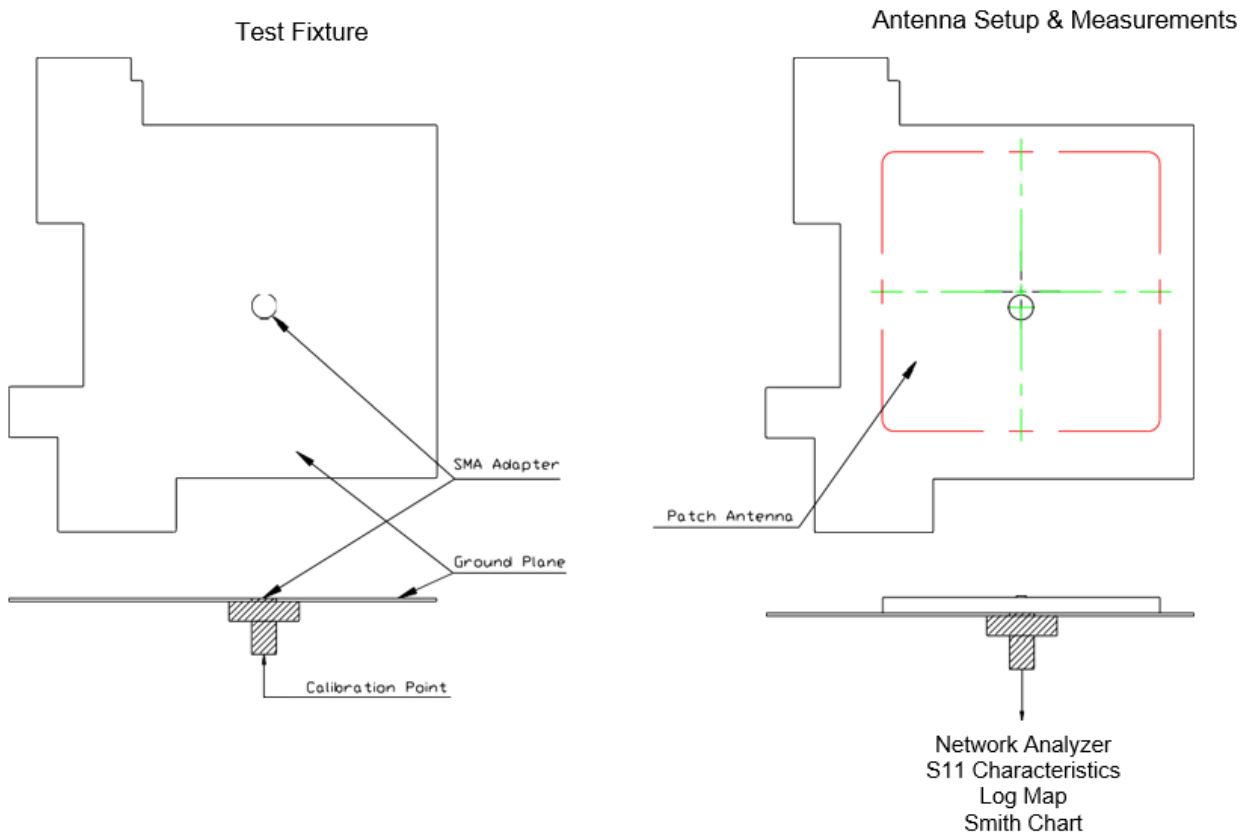

19. Test Jig and Dimension (With PCB)

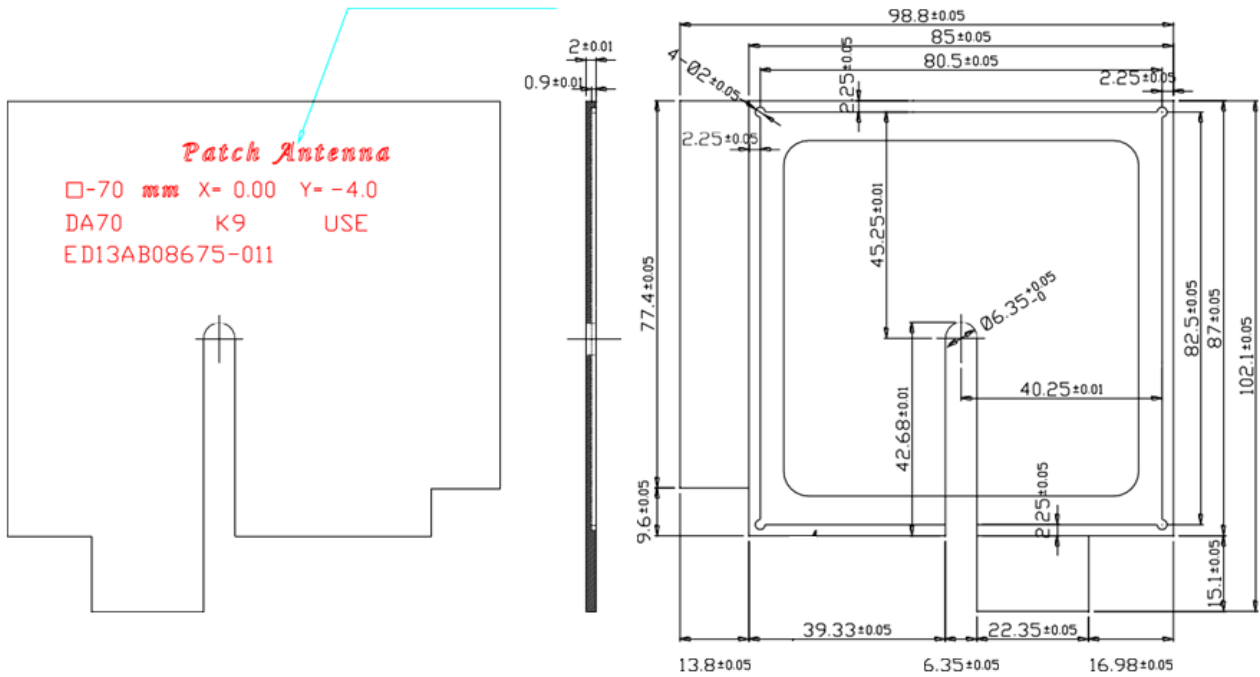

Bottom side

****Note: keep 90 degrees Chamfer if without any remark****

Top side

20. DA package disassembly

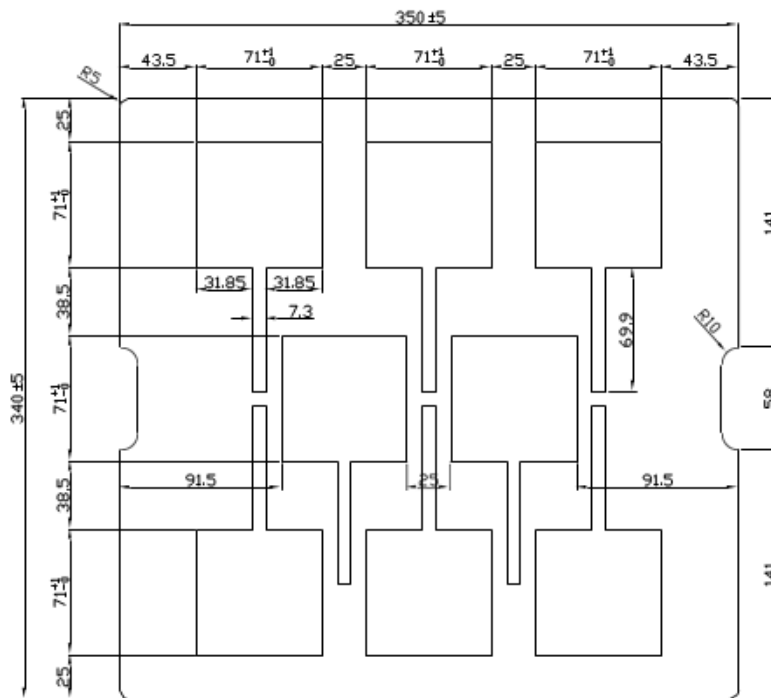

Paper partition plan (no printing)

Specification: 350x340mm

Material: 5 layers of 8mm corrugated paper

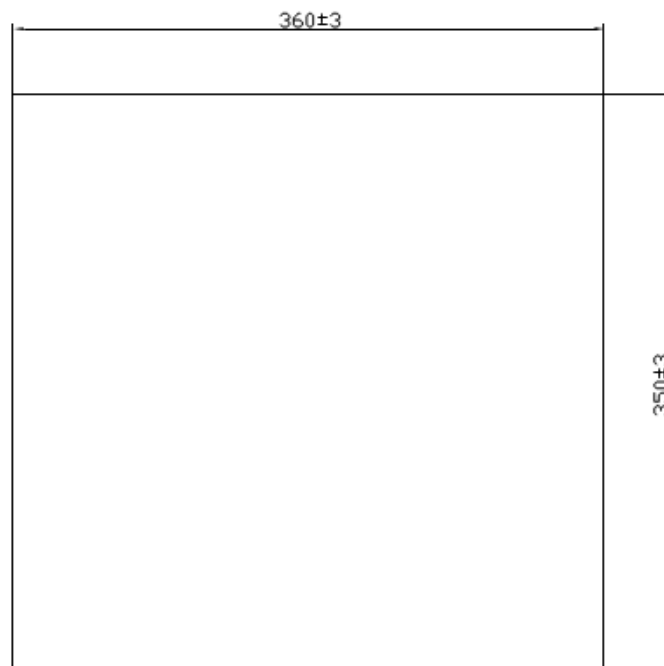

Partition plan