

TSL214 64 × 1 INTEGRATED OPTO SENSOR

SOES002E – JUNE 1991 – REVISED MARCH 1994

- On-Board 64-Bit Static Shift Register
- Extendable Data I/O for Expanding the Number of Sensors
- Analog Buffer With Sample and Hold for Analog Output Over Full Clock Period
- Single-Supply Operation
- 500-kHz Shift Clock
- 14-Pin Clear Plastic Package
- Advanced LinCMOS™ Technology

(TOP VIEW)

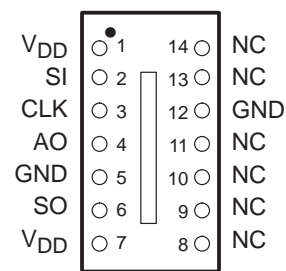

NC – No internal connection

description

The TSL214 integrated opto sensor consists of 64 charge-mode pixels arranged in a 64 × 1 linear array. Each pixel measures 120 μm × 70 μm, with 125-μm center-to-center spacing. Operation is simplified by internal logic requiring only clock and start-integration-pulse signals.

The TSL214 is intended for use in a wide variety of applications including linear and rotary encoding, bar-code reading, edge detection and positioning, and contact imaging.

The TSL214 is supplied in a 14-pin dual-in-line clear plastic package.



Caution. These devices have limited built-in gate protection. The leads should be shorted together or the device placed in conductive foam during storage or handling to prevent electrostatic damage to the MOS gates.

Advanced LinCMOS is a trademark of Texas Instruments Incorporated.

PRODUCTION DATA information is current as of publication date. Products conform to specifications per the terms of Texas Instruments standard warranty. Production processing does not necessarily include testing of all parameters.

TEXAS
INSTRUMENTS

POST OFFICE BOX 655303 • DALLAS, TEXAS 75265
POST OFFICE BOX 1443 • HOUSTON, TEXAS
77251-1443

Copyright © 1994, Texas Instruments Incorporated

TSL214

64 × 1 INTEGRATED OPTO SENSOR

SOES002E – JUNE 1991 – REVISED MARCH 1994

functional block diagram

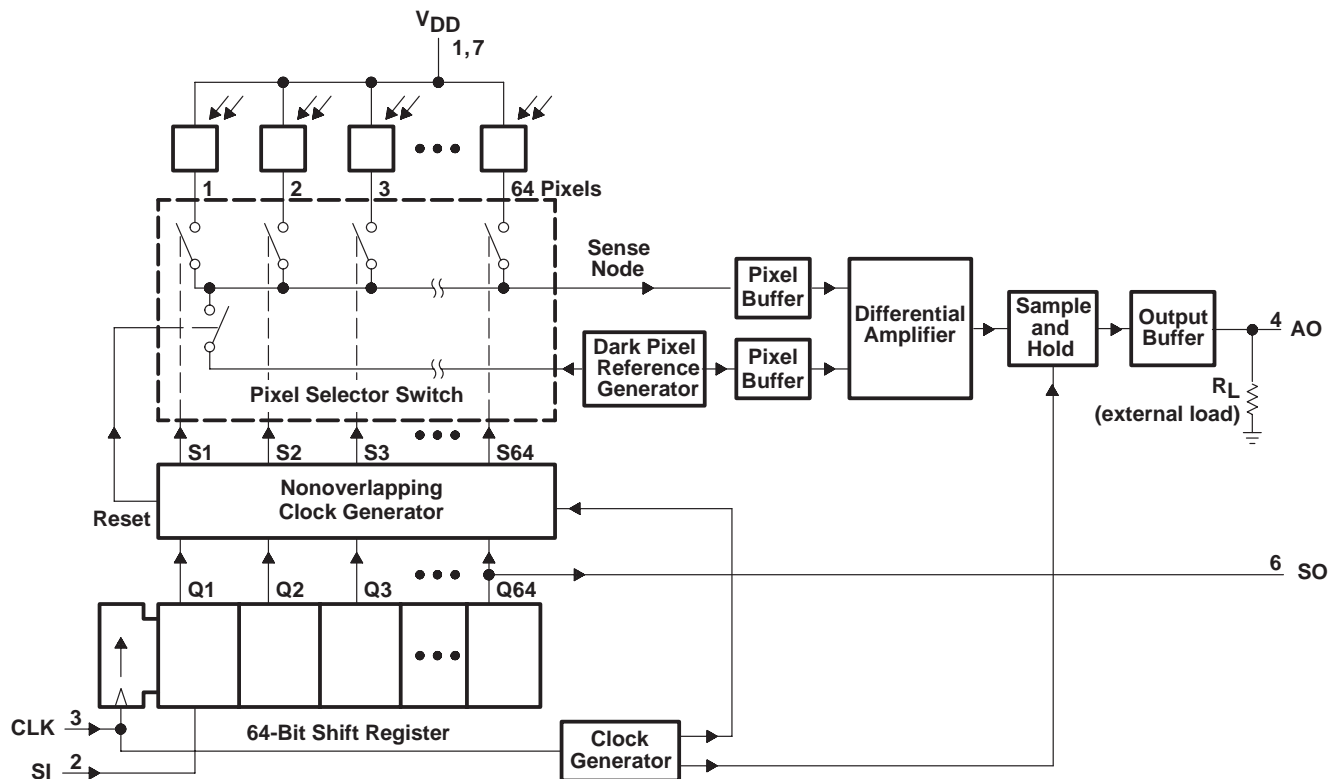

Terminal Functions

TERMINAL NAME	NO.	DESCRIPTION
AO	4	Analog output
CLK	3	Clock input. CLK controls charge transfer, pixel output, and reset.
GND	5, 12	Ground (substrate). All voltages are referenced to the substrate.
NC	8–11, 13, 14	No internal connection
SI	2	Serial input. SI defines the end of the integration period and initiates the pixel output sequence.
SO	6	Serial output. SO provides a signal to drive the SI input of another TSL214 sensor for cascading.
V _{DD}	1, 7	Supply voltage. V _{DD} supplies power to the analog and digital circuits.

detailed description

sensor elements

The line of sensor elements, called pixels, consists of 64 discrete photosensing areas. Light energy striking a pixel generates electron-hole pairs in the region under the pixel. The field generated by the bias on the pixel causes the electrons to collect in the element while the holes are swept into the substrate. The amount of charge accumulated in each element is directly proportional to the amount of incident light and the integration time.

device operation

Operation of the 64 × 1 array sensor consists of two time periods: an integration period during which charge is accumulated in the pixels and an output period during which signals are transferred to the output. The integration period is defined by the interval between serial-input (SI) pulses and includes the output period (see Figure 1). The required length of the integration period depends upon the amount of incident light and the desired output signal level.

sense node

On completion of the integration period, the charge contained in each pixel is transferred in turn to the sense node under the control of the clock (CLK) and SI signals. The signal voltage generated at this node is directly proportional to the amount of charge and inversely proportional to the capacitance of the sense node.

reset

An internal reset signal is generated by the nonoverlapping clock generator (NOCG) and occurs every clock cycle. Reset establishes a known voltage on the sense node in preparation for the next charge transfer. This voltage is used as a reference level for the differential signal amplifier.

shift register

The 64-bit shift register controls the transfer of charge from the pixels to the output stages and provides timing signals for the NOCG. The SI signal provides the input to the shift register and is shifted under direct control of the clock. The input is shifted out to the serial output (SO) on the 64th clock cycle. This SO pulse can then be used as the SI pulse for another device for multiple-unit operation.

The output period is initiated by the presence of the SI pulse coincident with a rising edge of the clock (Figures 1 and 2). The output voltage corresponds to the level of the first pixel after settling time (t_s) and remains constant for a valid time (t_v). A voltage corresponding to each succeeding pixel is available at each rising edge of the clock. The output period ends on the rising edge of the 65th clock cycle, at which time the output assumes a high-impedance state. The 65th clock cycle terminates the output of the last pixel and clears the shift register in preparation for the next SI pulse. To achieve minimum integration time, the SI pulse may be present on the 66th rising edge of the clock to immediately reinstate the output phase. Once the output period is initiated by an SI pulse, the clock must be allowed to complete 65 positive-going transitions in order to reset the internal logic to a known state.

sample-and-hold

The sample-and-hold signal generated by the NOCG is used to hold analog output voltage of each pixel constant until the next pixel is clocked out. The signal is sampled while the clock is high and held constant while the clock is low.

nonoverlapping clock generators

The NOCG circuitry provides internal control signals for the sensor, including reset and pixel-charge sensing. The signals are synchronous and are controlled by the outputs of the shift register.



TSL214

64 × 1 INTEGRATED OPTO SENSOR

SOES002E – JUNE 1991 – REVISED MARCH 1994

initialization

Initialization of the sensor elements may be necessary on power up or during operation after any period of clock or SI inactivity exceeding the integration time. The initialization phase consists of 12 to 15 consecutively performed output cycles and clears the pixels of any charge that may have accumulated during the inactive period.

multiple unit operation

Multiple sensor devices may be connected together in a serial or parallel configuration. The serial connection is accomplished by connecting analog outputs (AO) together and connecting the SO terminal of each sensor device to the SI terminal of the next device. The SI signal is applied to the first device only, with each succeeding device receiving its SI from the SO of the preceding device. For n cascaded devices, the SI pulse is applied to the first device after every $n \cdot 64$ positive-going clock transitions. A common clock signal is applied to all the devices simultaneously. Parallel operation of multiple devices is accomplished by supplying clock and SI signals to all the devices simultaneously. The output of each device is then separately used for processing.

output enable

The internally generated output-enable signal enables the output stage of the sensor during the output period (64 clock cycles). During the remainder of the integration period, the output stage is in the high-impedance state, which allows output interconnections of multiple devices without interference.

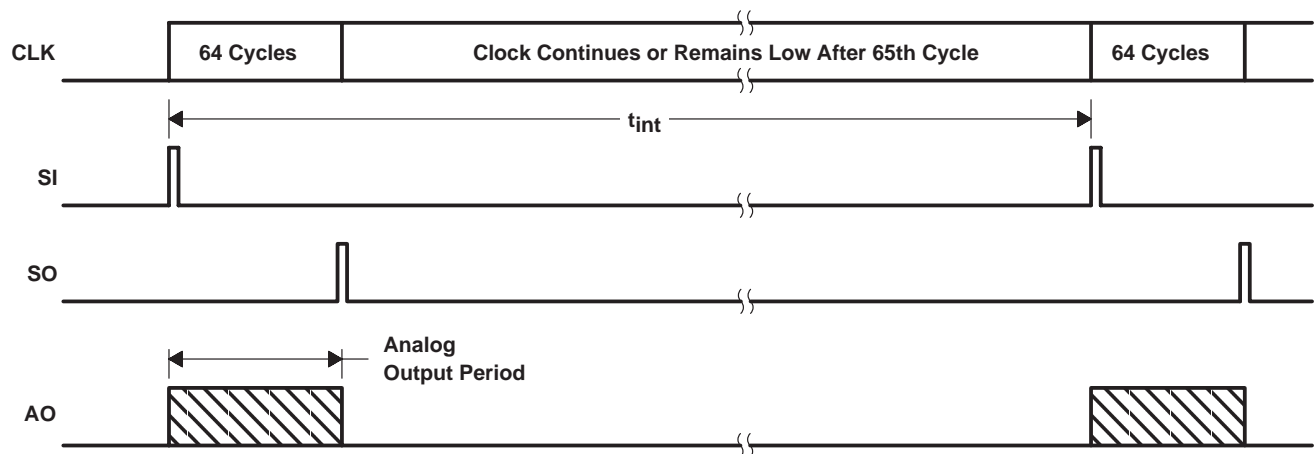

Figure 1. Timing Waveforms

TSL214

64 × 1 INTEGRATED OPTO SENSOR

SOES002E – JUNE 1991 – REVISED MARCH 1994

absolute maximum ratings over operating free-air temperature range (unless otherwise noted) (see Note 1)†

Supply voltage range, V_{DD} (see Note 1)	–0.5 V to 7 V
Digital output voltage range, V_O	–0.5 V to $V_{DD} + 0.5$ V
Digital output current, I_O	3 mA
Digital input current range, I_I	–20 mA to 20 mA
Operating case temperature range, T_C (see Note 2)	–10°C to 85°C
Operating free-air temperature range, T_A	0°C to 70°C
Storage temperature range	–25°C to 85°C
Lead temperature 1,6 mm (1/16 inch) from case for 10 seconds	260°C

† Stresses beyond those listed under “absolute maximum ratings” may cause permanent damage to the device. These are stress ratings only, and functional operation of the device at these or any other conditions beyond those indicated under “recommended operating conditions” is not implied. Exposure to absolute-maximum-rated conditions for extended periods may affect device reliability.

NOTES: 1. Voltage values are with respect to GND.

2. Case temperature is the surface temperature of the plastic measured directly over the integrated circuit.

recommended operating conditions

	MIN	NOM	MAX	UNIT
Supply voltage, V_{DD}	4.5		5.5	V
Input voltage, V_I	0		V_{DD}	V
High-level input voltage, V_{IH}	$V_{DD} \times 0.7$		V_{DD}	V
Low-level input voltage, V_{IL}	0		$V_{DD} \times 0.3$	V
Wavelength of light source, λ		750		nm
Clock input frequency, f_{clock}	10		500	kHz
Pulse duration, CLK low, $t_w(CLK_L)$	1			μ s
Sensor integration time, t_{int} (see Figures 1 and 2)		5		ms
Setup time, SI before $CLK\uparrow$, $t_{su}(SI)$	50			ns
Hold time, SI after $CLK\uparrow$, $t_h(SI)$	50			ns
External resistive load, AO, R_L		330		Ω
Total number of TSL214 outputs connected together			10	
Operating free-air temperature, T_A	0		70	°C



TSL214

64 × 1 INTEGRATED OPTO SENSOR

SOES002E – JUNE 1991 – REVISED MARCH 1994

electrical characteristics at $V_{DD} = 5\text{ V}$, $T_A = 25^\circ\text{C}$, $f_{\text{clock}} = 180\text{ kHz}$, $\lambda_p = 565\text{ nm}$, $R_L = 330\ \Omega$, $C_L = 330\text{ pF}$, $t_{\text{int}} = 5\text{ ms}$, $E_e = 20\ \mu\text{W}/\text{cm}^2$ (unless otherwise noted) (see Note 3)

PARAMETER	TEST CONDITIONS	MIN	TYP	MAX	UNIT
Low-level output voltage	$I_O = 0$			0.1	V
High-level output voltage		4.4			V
Analog output voltage saturation level	$E_e = 60\ \mu\text{W}/\text{cm}^2$	3	3.4		V
Analog output voltage (white, average over 64 pixels)		1.75	2.2		V
Analog output voltage (dark, each pixel)	$E_e = 0$		0.25	0.4	V
Output voltage (white) change with change in V_{DD}	$V_{DD} = 5\text{ V} \pm 5\%$		$\pm 2\%$		
Dispersion of analog output voltage	See Note 4			$\pm 7.5\%$	
Linearity of analog output voltage	See Note 5	0.85		1.15	
Pixel recovery time	See Note 6		25	40	ms
Supply current	I_{DD} (average)		4	9	mA
High-level input current	$V_I = V_{DD}$			0.5	μA
Low-level input current	$V_I = 0$			0.5	μA
Input capacitance			5		pF

- NOTES:
- The input irradiance (E_e) is supplied by an LED array with $\lambda_p = 565\text{ nm}$.
 - Dispersion of analog-output voltage is the maximum difference between the voltage from any single pixel and the average output voltage from all pixels of the device under test.
 - Linearity of analog-output voltage is calculated by averaging over 64 pixels and measuring the maximum deviation of the voltage at 2 ms and 3.5 ms from a line drawn between the voltage at 2.5 ms and the voltage at 5 ms.
 - Pixel recovery time is the time required for a pixel to go from the analog-output voltage (white, average over 64 pixels) level to analog-output voltage (dark, each pixel) level or vice versa after a step change in light input.

operating characteristics, $V_{DD} = 5\text{ V}$, $T_A = 25^\circ\text{C}$, $f_{\text{clock}} = 500\text{ kHz}$, $R_L = 330\ \Omega$, $C_L = 330\text{ pF}$, $t_{\text{int}} = 5\text{ ms}$, $E_e = 20\ \mu\text{W}/\text{cm}^2$ (unless otherwise noted)

PARAMETER	TEST CONDITIONS	MIN	TYP	MAX	UNIT
$t_r(\text{SO})$ Rise time, SO	See Figure 2 and Note 7		25		ns
$t_f(\text{SO})$ Fall time, SO			25		ns
$t_{pd}(\text{SO})$ Propagation delay time, SO			70		ns
t_s Settling time				1	μs
t_v Valid time				$1/2 f_{\text{clock}}$	μs

NOTE 7: Clock duty cycle is assumed to be 50%.

PARAMETER MEASUREMENT INFORMATION

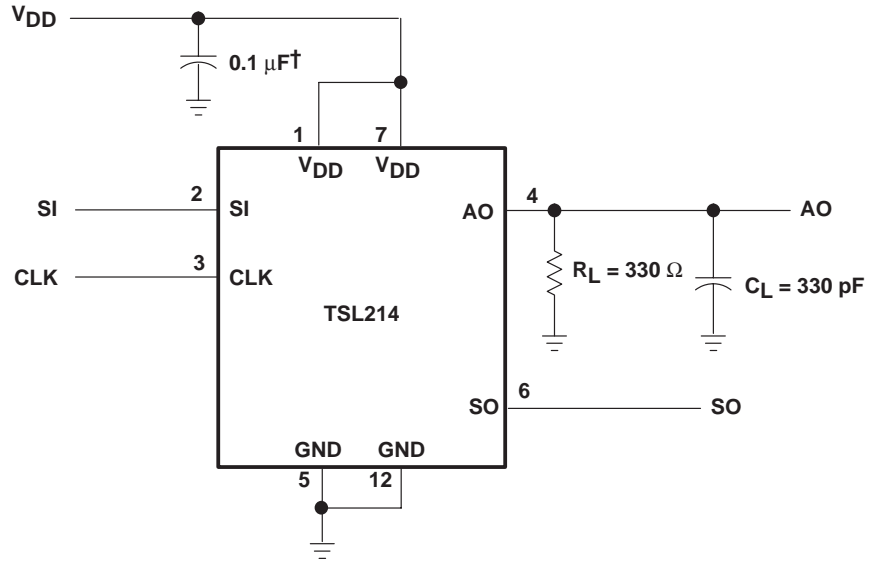

† Supply bypass capacitor with short leads should be placed as close to the device as possible.

TEST CIRCUIT

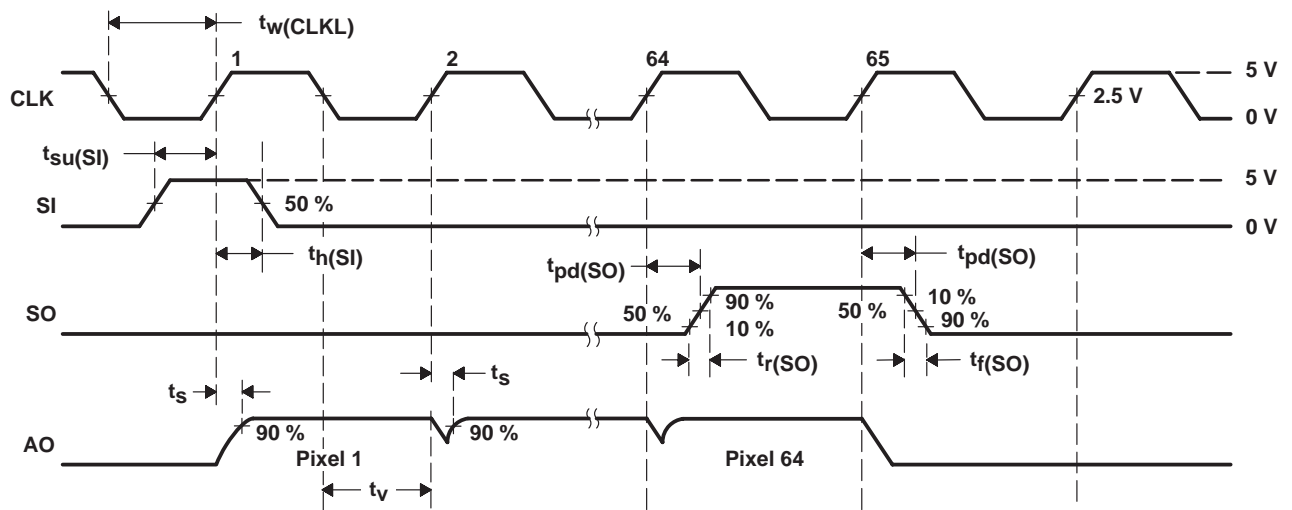

OPERATIONAL WAVEFORMS

Figure 2. Test Circuit and Operational Waveforms

TSL214

64 × 1 INTEGRATED OPTO SENSOR

SOES002E – JUNE 1991 – REVISED MARCH 1994

TYPICAL CHARACTERISTICS

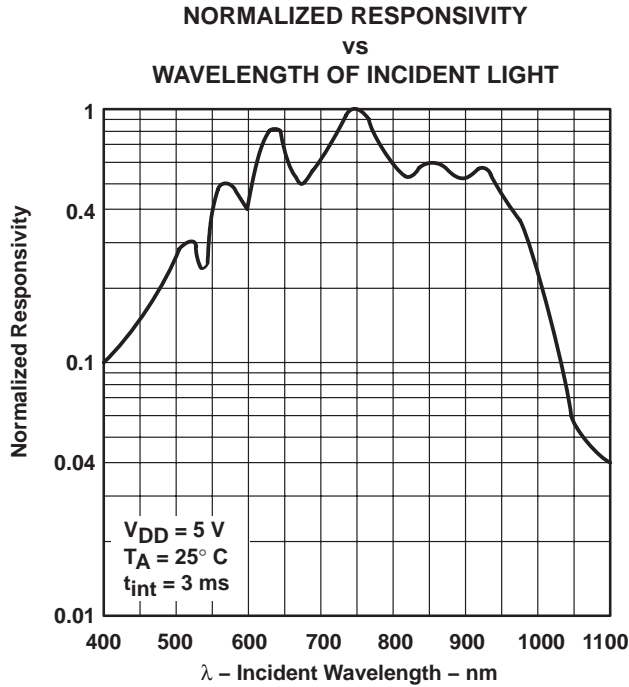

Figure 3

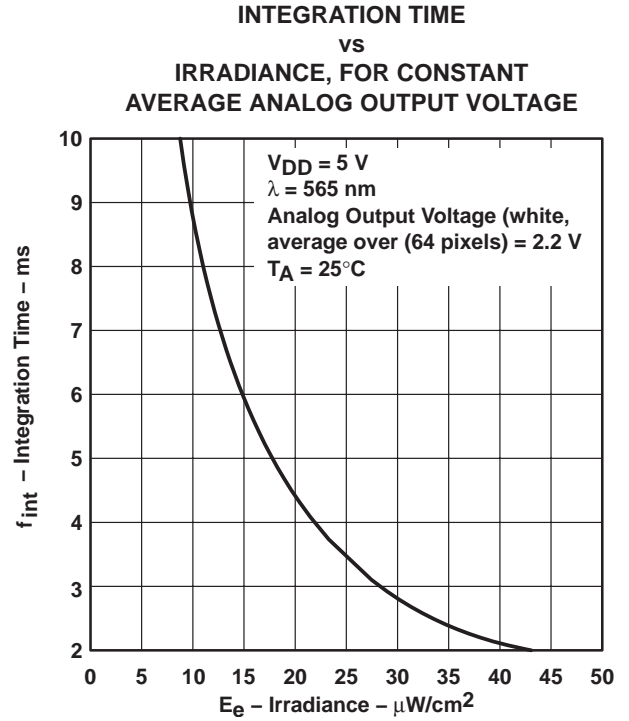

Figure 4

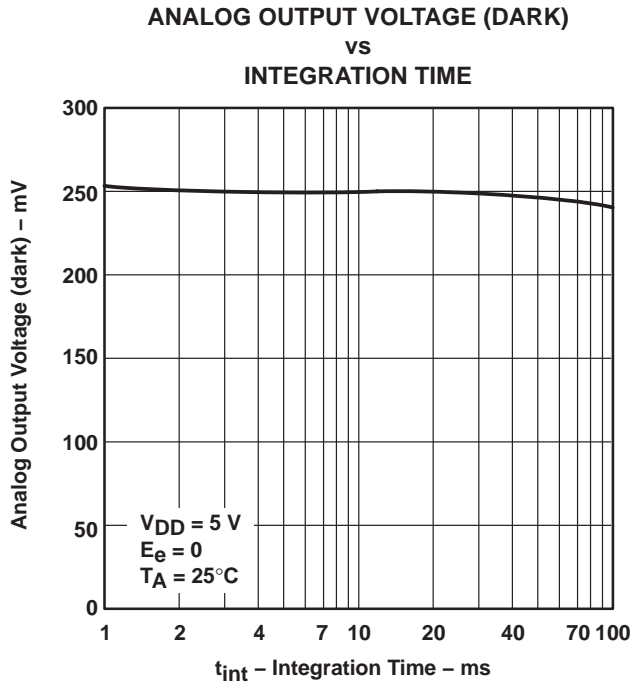

Figure 5

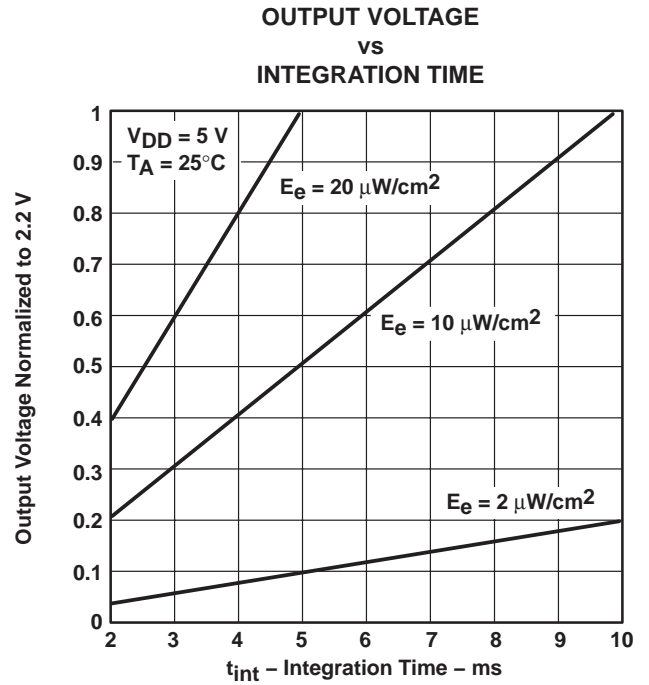
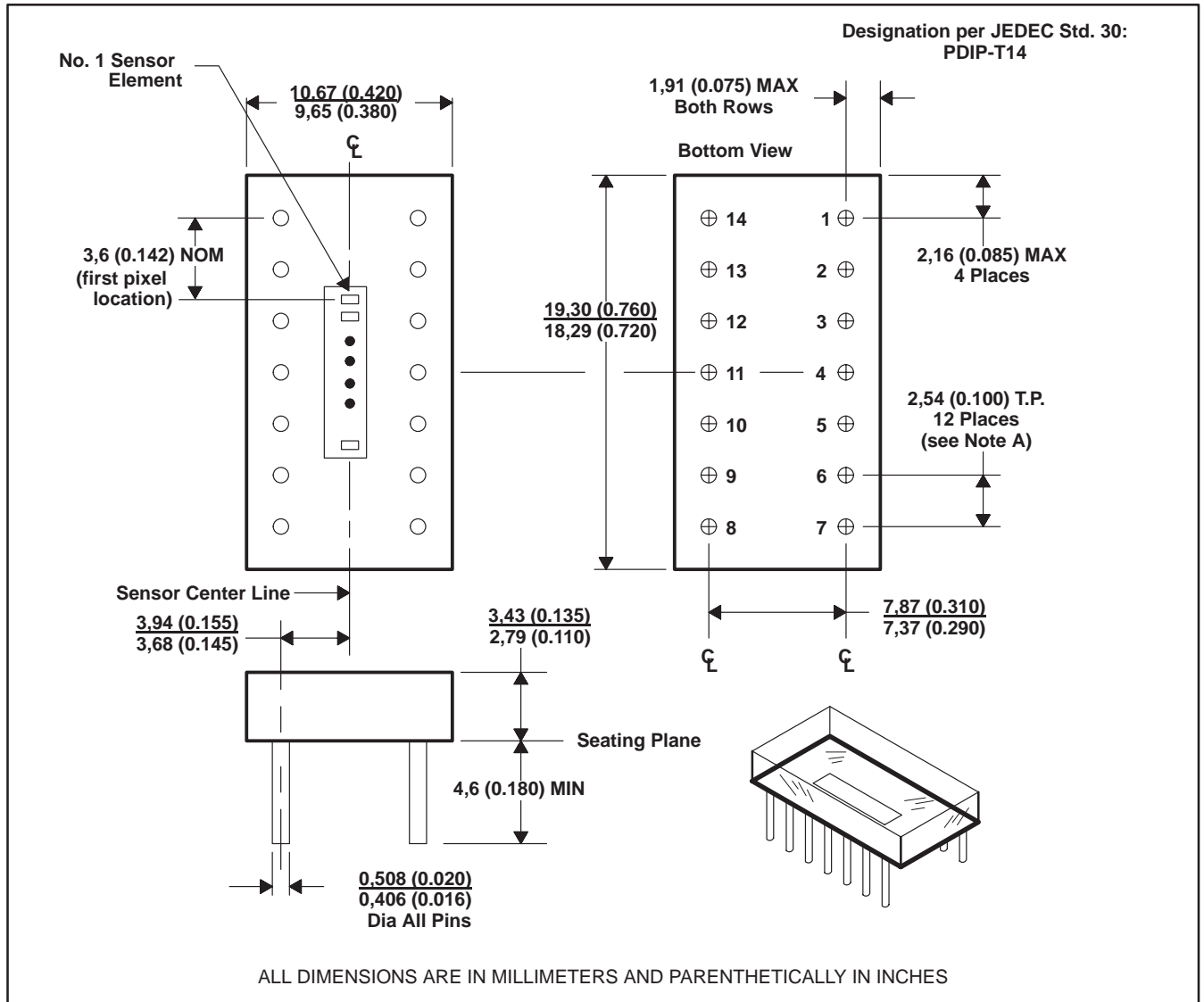

Figure 6

MECHANICAL DATA

This assembly consists of a sensor chip mounted on a printed circuit board in a clear molded plastic package. The distance between the top surface of the package and the surface of the sensor is nominally 1,0 mm (0.040 inch).



NOTE A: The true-position spacing is 2,54 mm (0.100 inch) between lead centerlines. Each pin centerline is located within 0,25 mm (0.010 inch) of its true longitudinal positions.

PACKAGING INFORMATION

Orderable Device	Status ⁽¹⁾	Package Type	Package Drawing	Pins	Package Qty	Eco Plan ⁽²⁾	Lead/Ball Finish	MSL Peak Temp ⁽³⁾
TSL214	OBSOLETE	XCEPT	COB	14		TBD	Call TI	Call TI

⁽¹⁾ The marketing status values are defined as follows:

ACTIVE: Product device recommended for new designs.

LIFEBUY: TI has announced that the device will be discontinued, and a lifetime-buy period is in effect.

NRND: Not recommended for new designs. Device is in production to support existing customers, but TI does not recommend using this part in a new design.

PREVIEW: Device has been announced but is not in production. Samples may or may not be available.

OBSOLETE: TI has discontinued the production of the device.

⁽²⁾ Eco Plan - The planned eco-friendly classification: Pb-Free (RoHS), Pb-Free (RoHS Exempt), or Green (RoHS & no Sb/Br) - please check <http://www.ti.com/productcontent> for the latest availability information and additional product content details.

TBD: The Pb-Free/Green conversion plan has not been defined.

Pb-Free (RoHS): TI's terms "Lead-Free" or "Pb-Free" mean semiconductor products that are compatible with the current RoHS requirements for all 6 substances, including the requirement that lead not exceed 0.1% by weight in homogeneous materials. Where designed to be soldered at high temperatures, TI Pb-Free products are suitable for use in specified lead-free processes.

Pb-Free (RoHS Exempt): This component has a RoHS exemption for either 1) lead-based flip-chip solder bumps used between the die and package, or 2) lead-based die adhesive used between the die and leadframe. The component is otherwise considered Pb-Free (RoHS compatible) as defined above.

Green (RoHS & no Sb/Br): TI defines "Green" to mean Pb-Free (RoHS compatible), and free of Bromine (Br) and Antimony (Sb) based flame retardants (Br or Sb do not exceed 0.1% by weight in homogeneous material)

⁽³⁾ MSL, Peak Temp. -- The Moisture Sensitivity Level rating according to the JEDEC industry standard classifications, and peak solder temperature.

Important Information and Disclaimer:The information provided on this page represents TI's knowledge and belief as of the date that it is provided. TI bases its knowledge and belief on information provided by third parties, and makes no representation or warranty as to the accuracy of such information. Efforts are underway to better integrate information from third parties. TI has taken and continues to take reasonable steps to provide representative and accurate information but may not have conducted destructive testing or chemical analysis on incoming materials and chemicals. TI and TI suppliers consider certain information to be proprietary, and thus CAS numbers and other limited information may not be available for release.

In no event shall TI's liability arising out of such information exceed the total purchase price of the TI part(s) at issue in this document sold by TI to Customer on an annual basis.

IMPORTANT NOTICE

Texas Instruments Incorporated and its subsidiaries (TI) reserve the right to make corrections, modifications, enhancements, improvements, and other changes to its products and services at any time and to discontinue any product or service without notice. Customers should obtain the latest relevant information before placing orders and should verify that such information is current and complete. All products are sold subject to TI's terms and conditions of sale supplied at the time of order acknowledgment.

TI warrants performance of its hardware products to the specifications applicable at the time of sale in accordance with TI's standard warranty. Testing and other quality control techniques are used to the extent TI deems necessary to support this warranty. Except where mandated by government requirements, testing of all parameters of each product is not necessarily performed.

TI assumes no liability for applications assistance or customer product design. Customers are responsible for their products and applications using TI components. To minimize the risks associated with customer products and applications, customers should provide adequate design and operating safeguards.

TI does not warrant or represent that any license, either express or implied, is granted under any TI patent right, copyright, mask work right, or other TI intellectual property right relating to any combination, machine, or process in which TI products or services are used. Information published by TI regarding third-party products or services does not constitute a license from TI to use such products or services or a warranty or endorsement thereof. Use of such information may require a license from a third party under the patents or other intellectual property of the third party, or a license from TI under the patents or other intellectual property of TI.

Reproduction of TI information in TI data books or data sheets is permissible only if reproduction is without alteration and is accompanied by all associated warranties, conditions, limitations, and notices. Reproduction of this information with alteration is an unfair and deceptive business practice. TI is not responsible or liable for such altered documentation. Information of third parties may be subject to additional restrictions.

Resale of TI products or services with statements different from or beyond the parameters stated by TI for that product or service voids all express and any implied warranties for the associated TI product or service and is an unfair and deceptive business practice. TI is not responsible or liable for any such statements.

TI products are not authorized for use in safety-critical applications (such as life support) where a failure of the TI product would reasonably be expected to cause severe personal injury or death, unless officers of the parties have executed an agreement specifically governing such use. Buyers represent that they have all necessary expertise in the safety and regulatory ramifications of their applications, and acknowledge and agree that they are solely responsible for all legal, regulatory and safety-related requirements concerning their products and any use of TI products in such safety-critical applications, notwithstanding any applications-related information or support that may be provided by TI. Further, Buyers must fully indemnify TI and its representatives against any damages arising out of the use of TI products in such safety-critical applications.

TI products are neither designed nor intended for use in military/aerospace applications or environments unless the TI products are specifically designated by TI as military-grade or "enhanced plastic." Only products designated by TI as military-grade meet military specifications. Buyers acknowledge and agree that any such use of TI products which TI has not designated as military-grade is solely at the Buyer's risk, and that they are solely responsible for compliance with all legal and regulatory requirements in connection with such use.

TI products are neither designed nor intended for use in automotive applications or environments unless the specific TI products are designated by TI as compliant with ISO/TS 16949 requirements. Buyers acknowledge and agree that, if they use any non-designated products in automotive applications, TI will not be responsible for any failure to meet such requirements.

Following are URLs where you can obtain information on other Texas Instruments products and application solutions:

Products

Amplifiers	amplifier.ti.com
Data Converters	dataconverter.ti.com
DLP® Products	www.dlp.com
DSP	dsp.ti.com
Clocks and Timers	www.ti.com/clocks
Interface	interface.ti.com
Logic	logic.ti.com
Power Mgmt	power.ti.com
Microcontrollers	microcontroller.ti.com
RFID	www.ti-rfid.com
RF/IF and ZigBee® Solutions	www.ti.com/lprf

Applications

Audio	www.ti.com/audio
Automotive	www.ti.com/automotive
Broadband	www.ti.com/broadband
Digital Control	www.ti.com/digitalcontrol
Medical	www.ti.com/medical
Military	www.ti.com/military
Optical Networking	www.ti.com/opticalnetwork
Security	www.ti.com/security
Telephony	www.ti.com/telephony
Video & Imaging	www.ti.com/video
Wireless	www.ti.com/wireless

Mailing Address: Texas Instruments, Post Office Box 655303, Dallas, Texas 75265
Copyright © 2009, Texas Instruments Incorporated