

Signal Chain Power Series LT3471 Dual Output Boost/Inverter

DESCRIPTION

Demonstration circuit SCP-LT3471-EVALZ is a dual output converter featuring the LT3471EDD in boost and inverter configurations. Both converters are powered from the same 4.5V to 10V input source. The Boost converter puts out 12V at 300mA and the Inverter -12V at 200mA.

Like all boards in the Signal Chain Power series, this board is designed to be easily plugged into other SCP boards to form a complete signal chain power system, enabling fast evaluation of low power signal chains. To evaluate this board, some universal SCP hardware is required, namely:

- SCP-INPUT-EVALZ SCP-FILTER-EVALZ
- SCP-OUTPUT-EVALZ SCP-1X2BKOUT-EVALZ
- SCP-1X5BKOUT-EVALZ SCP-5X1-EVALZ
- SCP-THRUBRD-EVALZ

To properly evaluate SCP series demo boards, you will need the SCP Configurator companion software. SCP Configurator can help you choose the right board and topology for your design.

Note that this Demo Manual does not cover details important to the operation and configuration regarding the [LT3471](#). Please refer to the [LT3471 datasheet](#) for a complete description of the part.

Design files for this circuit board are available.

All registered trademarks and trademarks are property of their respective owners.

Table 1. Performance Summary

SYMBOL	PARAMETER	NOTES	MIN	TYP	MAX	UNITS
V _{IN(MAX)}	Max Input Voltage				15	V
V _{OUT(MAX)}	Max Output Voltage	Positive V _{OUT} Negative V _{OUT}			+40 -40	V
I _{SW(LIM)}	Switch Current Limit		1.5 0.9	2.05 1.45	2.6 2.0	A

BOARD PHOTO

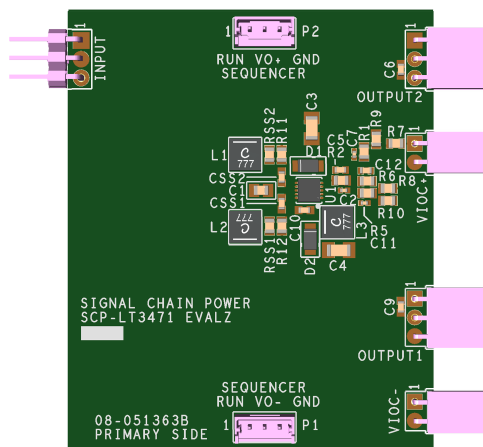

Figure 1. Photo of SCP-LT3471-EVALZ

DEMO MANUAL SCP-LT3471-EVALZ

QUICK START PROCEDURE

Demonstration circuit SCP-LT3471-EVALZ is easy to set up to evaluate the performance of any SCP hardware configuration.

1. The SCP-LT3471-EVALZ ships with a default output voltage of $\pm 40V$. To change the output voltage, see “Configuration Settings” section, and modify the board accordingly. Be sure to check for open connections or solder shorts after making any modifications.
2. Connect the SCP-INPUT-EVALZ and SCP-OUTPUT-EVALZ boards to the SCP-LT3471-EVALZ (refer to Figure 2) and connect the input board to a voltage source, V_{SOURCE} . Connect the output board to a voltmeter or dynamic load. Slowly raise the input voltage until the SCP-LT3471-EVALZ powers up into regulation and sweep V_{SOURCE} through the desired range of operation.

NOTE: Make sure that the input voltage is always within spec. If using a dynamic load to measure output voltage, make sure the load is initially set to zero.

3. Check for proper output voltages. The output should be regulated at the programmed value ($\pm 5\%$).
4. Once the proper output voltage is established, power off V_{SOURCE} and similarly test other boards in the SCP system until all elements have been individually verified prior to assembling into the final circuit configuration.

NOTE: When measuring the input or output voltage ripple, use the optional SMA connector locations available on the input, output, 1×5 , 1×2 , and 5×1 breakout boards. Avoid using the test point connections with long scope leads.

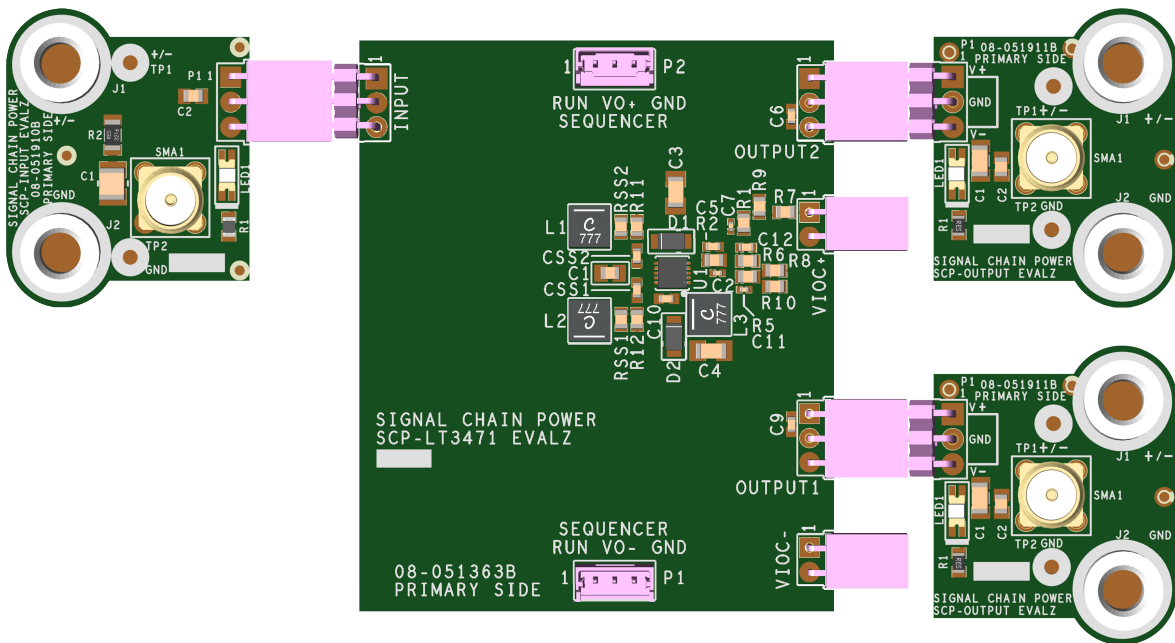

Figure 2. Proper Measurement Equipment Setup (Use SMA connectors for Measuring Input or Output Ripple)

CONFIGURATION SETTINGS

Demonstration circuit SCP-LT3471-EVALZ is a dual output converter featuring the LT3471EDD in Boost and Inverter configurations. Both converters are powered from the same 4.5V to 10V input source. The Boost converter puts out 12V at 300mA and the Inverter -12V at 200mA.

The output voltages of the SCP-LT3471-EVALZ are resistor-programmable from ±5V to ±40V. The board can be also configured to drive VIOC-capable linear regulators.

OUTPUT VOLTAGE PROGRAMMING

$$+V_{OUT1} = 1.0V_{REF} \left(1 + \frac{R1}{R2} \right)$$

$$-V_{OUT2} = 1.0V_{REF} \left(\frac{R5}{R6} \right)$$

Table 2. Resistor Selection Guide for Common Output Voltages

V _{OUT} (V)	R1 (Ω)	R2 (Ω)	R5 (Ω)	R6 (Ω)
5.0	102k	25.5k	115k	25.5k
5.5	115k	25.5k	59.0k	11.8k
6.0	59.0k	11.8k	64.9k	11.8k
6.5	64.9k	11.8k	107k	17.8k
7.0	107k	17.8k	71.5k	11.0k
7.5	71.5k	11.0k	93.1k	13.3k
8.0	93.1k	13.3k	75.0k	10.0k
8.5	75.0k	10.0k	150k	18.7k
9.0	150k	18.7k	113k	13.3k
9.5	113k	13.3k	102k	11.3k
10.0	102k	11.3k	100k	10.0k
11.0	100k	10.0k	110k	10.0k
12.0	110k	10.0k	165k	13.7k
13.0	165k	13.7k	130k	10.0k
14.0	130k	10.0k	140k	10.0k
15.0	140k	10.0k	150k	10.0k
16.0	150k	10.0k	169k	10.5k
17.0	169k	10.5k	187k	11.0k
18.0	187k	11.0k	294k	16.2k
19.0	294k	16.2k	215k	11.3k
20.0	215k	11.3k	255k	10.7k
25.0	255k	10.7k	261k	11.3k
30.0	309k	10.7k	280k	10k
35.0	340k	10.0k	102k	30.9k
40.0	976k	24.9k	523k	13.7k

SHDN/SS PINS CONFIGURATION

The SHDN/SS1 and SHDN/SS2 pins are tied to the optional SCP Run/Sequence header. To create a harness for this function, use Molex part 0510650300 with crimp pin 50212-8000.

The pins allow run/shutdown operation and provide soft start function as well. To set both channels high and use soft start with pinstrapping (default), use 4.7k for both R_{SS1} and R_{SS2}. The combination of R_{SS} and C_{SS} values determines the soft start period. A typical value of R_{SS} = 4.7k and C_{SS} = 0.33μF yields soft start times on the order of a few milliseconds before full cycle-by-cycle switch current limit is reached.

To use an active run signal, use a 100k resistor for either pull-up or pull-down resistors R9, R10, R12 and R13, short R11 and R14 with 0Ω, respectively, and use the drive signal from connectors P1 and P2.

To shut down the part, pull SHDN pin below 0.3V.

VOLTAGE INPUT-TO-OUTPUT CONTROL (VIOC) IMPLEMENTATION

To implement the VIOC function for both regulators, set R7 and R8 to 0Ω, respectively. Refer to the “Configuration Settings” section in the Demo Manual for the low-dropout (LDO) linear regulator board and use the following configuration for this board.

Table 3. VIOC Cross-Reference Designators

VIOC SETTING REFERENCES	R _{BOT}	R _{TOP}	R _{MAX}
V _{OUT} Reference Designators for VOUT1	R2	R1	R9
V _{OUT} Reference Designators for VOUT2	R6	R5	R10

Positive VIOC equations

$$V_{LDOIN} - V_{LDOOUT} = V_{VIOC} = 1.0V_{FB} \left(\frac{R_{BOT} + R_{TOP}}{R_{BOT}} \right)$$

$$V_{(MAX)LDOIN} = 1.0V_{FB} \left(\frac{R_{BOT} + R_{TOP} + R_{MAX}}{R_{BOT}} \right) + I_{SINK}R_{MAX}$$

I_{SINK} is the current through R_{MAX}, typically 15μA, so R_{BOT} should be sized such that the divider current runs a minimum of 100μA to minimize the I_{SINK} error term.

Negative VIOC equations

$$V_{LDOIN} - V_{LDOOUT} = V_{VIOC} = 1.0V_{FB} \left(\frac{R_{TOP}}{R_{BOT}} \right)$$

$$V_{(MAX)LDOIN} = 1.0V_{FB} \left(\frac{R_{TOP} + R_{MAX}}{R_{BOT}} \right) + V_{VIOC} \left(\frac{R_{MAX}}{40k} \right)$$

Because the V_{LDOIN} term is simply the sum of the final output voltage after the LDO and the difference the LT3471 is adding on top, it can be helpful to take the desired final output voltage, add 1.0V, and then look up that voltage-resistor combination from Table 2.

R_{MAX} can then be obtained by figuring out the difference between the maximum and nominal output voltage of the LT3471, divided by the current through the internal R_{BOT} resistor, which is $1V/R_{BOT}$.

DEMO MANUAL SCP-LT3471-EVALZ

PARTS LIST

ITEM	QTY	REFERENCE	PART DESCRIPTION	MANUFACTURER/PART NUMBER
1	1	PCB	PCB	ANALOG DEVICES08_051363b
2	1	C1	CAP CER 4.7UF 25V 10% X5R 0805	SAMSUNG CL21A475KAQNNNG
3	1	C2	CAP CER 0.1UF 16V CER X7R 0402	KEMET C0402C104K4RACTU
4	2	C3, C4	CAP CER 10UF 50V X5R 1206	SAMSUNG CL31A106MBHNNNE
5	2	C5, C12	CAP MLCC 0603 (Note 1)	N/A
6	3	C6, C9, C10	CAP CER 1UF 50V 10% X5R 0603	SAMSUNG CL10A105KB8NNNC
7	2	C7, C11	CAP CER 100PF 50V COG/NPO 0402	MURATA GCM1555C1H101FA16D
8	2	C _{SS1} , C _{SS2}	CAP CER 0.33UF 16V 10% X7R 0603	SAMSUNG CL10B334K08NNNC
9	2	D1, D2	DIO SCHOTTKY BARRIER RECTIFIER, 1A	DIODES INCORPORATED DFLS120L-7
10	1	INPUT	CONN-PCB MALE HEADER 3POS 2.54MM PITCH R/A GOLD	SULLINS PBC03SBAN
11	1	L1	IND POWER, 0.216OHM MAX DCR, 0.84A	TAIYO YUDEN NR4018T100M
12	2	L2, L3	IND POWER, 0.48OHM MAX DCR, 0.56A	TAIYO YUDEN NR4012T150M
13	2	OUTPUT1, OUTPUT2	CONN FEMALE 3POS 2.54MM PITCH R/A GOLD	SULLINS PPPC031LGBN-RC
14	2	P1, P2	CONN-PCB 3POS HEADER WIRE TO BRD WAFER ASSY STRAIGHT 2MM PITCH (Note 1)	MOLEX 53253-0370
15	1	R1	RES SMD 54.9k OHM 1% 1/8W 0805	YAGEO RC0805FR-0754K9L
16	1	R2	RES 4.99k 1% THICK FILM 0805	PANASONIC ERJ-6ENF4991V
17	1	R5	RES 182k 1% THICK FILM 0805	VISHAY CRCW0805182KFKEA
18	1	R6	RES 15k 1% THICK FILM 0805	PANASONIC ERA-6AEB153V
19	4	R7, R8, R11, R12	RES THICK FILM 0805 (Note 1)	N/A
20	2	R9, R10	RES STANDARD THICK FILM CHIP JUMPER, FOR AUTOMOTIVE	VISHAY CRCW08050000Z0EA
21	2	R _{SS1} , R _{SS2}	RES 4.7k 5% THICK FILM 0805	NIC COMP CORP NRC10J472TRF
22	1	U1	IC-LIN DUAL 1.3A, 1.2MHZ BOOST INVERTER	LINEAR TECHNOLOGY LT3471EDD#PBF
23	2	VI0C+, VI0C-	CONN FEMALE 2POS 2.54MM PITCH R/A GOLD	SULLINS PPPC021LGBN-RC

Note 1. These items are not stuffed (DNI).

DEMO MANUAL SCP-LT3471-EVALZ

SCHEMATIC DIAGRAM

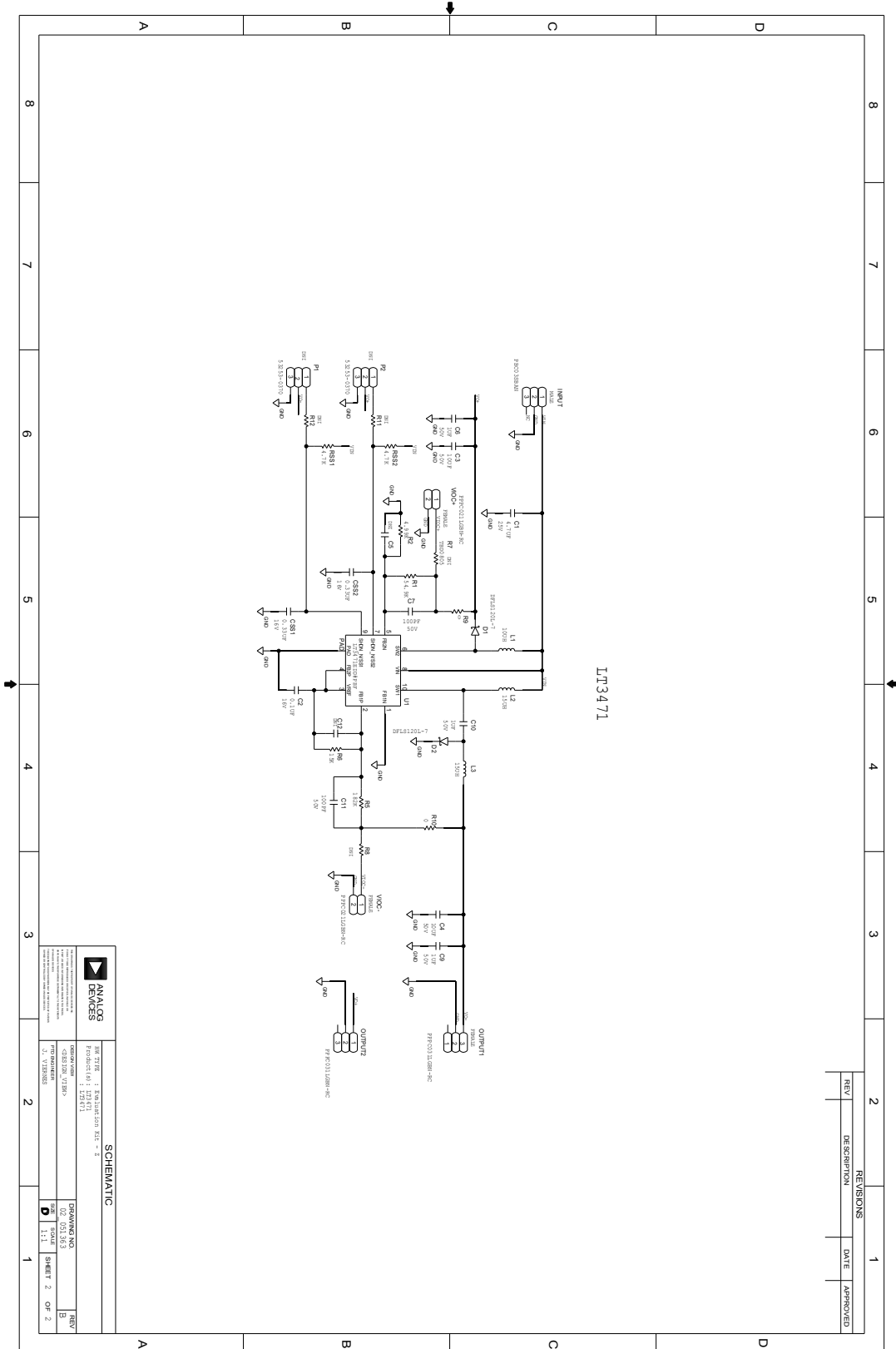

REV	DESCRIPTION	DATE	APPROVED

ANALOG DEVICES		SCHEMATIC	
REV	1	DRAWING NO.	12
DATE	11/11	SHEET 2	OF 2
DESIGNED BY	J. VERRILL	APPROVED BY	
CHECKED BY			

DEMO MANUAL SCP-LT3471-EVALZ



ESD Caution

ESD (electrostatic discharge) sensitive device. Charged devices and circuit boards can discharge without detection. Although this product features patented or proprietary protection circuitry, damage may occur on devices subjected to high energy ESD. Therefore, proper ESD precautions should be taken to avoid performance degradation or loss of functionality.

Legal Terms and Conditions

By using the evaluation board discussed herein (together with any tools, components documentation or support materials, the "Evaluation Board"), you are agreeing to be bound by the terms and conditions set forth below ("Agreement") unless you have purchased the Evaluation Board, in which case the Analog Devices Standard Terms and Conditions of Sale shall govern. Do not use the Evaluation Board until you have read and agreed to the Agreement. Your use of the Evaluation Board shall signify your acceptance of the Agreement. This Agreement is made by and between you ("Customer") and Analog Devices, Inc. ("ADI"), with its principal place of business at One Technology Way, Norwood, MA 02062, USA. Subject to the terms and conditions of the Agreement, ADI hereby grants to Customer a free, limited, personal, temporary, non-exclusive, non-sublicensable, non-transferable license to use the Evaluation Board FOR EVALUATION PURPOSES ONLY. Customer understands and agrees that the Evaluation Board is provided for the sole and exclusive purpose referenced above, and agrees not to use the Evaluation Board for any other purpose. Furthermore, the license granted is expressly made subject to the following additional limitations: Customer shall not (i) rent, lease, display, sell, transfer, assign, sublicense, or distribute the Evaluation Board; and (ii) permit any Third Party to access the Evaluation Board. As used herein, the term "Third Party" includes any entity other than ADI, Customer, their employees, affiliates and in-house consultants. The Evaluation Board is NOT sold to Customer; all rights not expressly granted herein, including ownership of the Evaluation Board, are reserved by ADI. CONFIDENTIALITY. This Agreement and the Evaluation Board shall all be considered the confidential and proprietary information of ADI. Customer may not disclose or transfer any portion of the Evaluation Board to any other party for any reason. Upon discontinuation of use of the Evaluation Board or termination of this Agreement, Customer agrees to promptly return the Evaluation Board to ADI. ADDITIONAL RESTRICTIONS. Customer may not disassemble, decompile or reverse engineer chips on the Evaluation Board. Customer shall inform ADI of any occurred damages or any modifications or alterations it makes to the Evaluation Board, including but not limited to soldering or any other activity that affects the material content of the Evaluation Board. Modifications to the Evaluation Board must comply with applicable law, including but not limited to the RoHS Directive. TERMINATION. ADI may terminate this Agreement at any time upon giving written notice to Customer. Customer agrees to return to ADI the Evaluation Board at that time. LIMITATION OF LIABILITY. THE EVALUATION BOARD PROVIDED HEREUNDER IS PROVIDED "AS IS" AND ADI MAKES NO WARRANTIES OR REPRESENTATIONS OF ANY KIND WITH RESPECT TO IT. ADI SPECIFICALLY DISCLAIMS ANY REPRESENTATIONS, ENDORSEMENTS, GUARANTEES, OR WARRANTIES, EXPRESS OR IMPLIED, RELATED TO THE EVALUATION BOARD INCLUDING, BUT NOT LIMITED TO, THE IMPLIED WARRANTY OF MERCHANTABILITY, TITLE, FITNESS FOR A PARTICULAR PURPOSE OR NON-INFRINGEMENT OF INTELLECTUAL PROPERTY RIGHTS. IN NO EVENT WILL ADI AND ITS LICENSORS BE LIABLE FOR ANY INCIDENTAL, SPECIAL, INDIRECT OR CONSEQUENTIAL DAMAGES RESULTING FROM CUSTOMER'S POSSESSION OR USE OF THE EVALUATION BOARD, INCLUDING BUT NOT LIMITED TO LOST PROFITS, DELAY COSTS, LABOR COSTS OR LOSS OF GOODWILL. ADI'S TOTAL LIABILITY FROM ANY AND ALL CAUSES SHALL BE LIMITED TO THE AMOUNT OF ONE HUNDRED US DOLLARS (\$100.00). EXPORT. Customer agrees that it will not directly or indirectly export the Evaluation Board to another country, and that it will comply with all applicable United States federal laws and regulations relating to exports. GOVERNING LAW. This Agreement shall be governed by and construed in accordance with the substantive laws of the Commonwealth of Massachusetts (excluding conflict of law rules). Any legal action regarding this Agreement will be heard in the state or federal courts having jurisdiction in Suffolk County, Massachusetts, and Customer hereby submits to the personal jurisdiction and venue of such courts. The United Nations Convention on Contracts for the International Sale of Goods shall not apply to this Agreement and is expressly disclaimed.