

# SLF7032-KIT

## Wire Wound Ferrite Power Inductor Sample Kit



### PRODUCT HIGHLIGHTS

- Magnetically shielded wound inductor with ferrite core
- Offers a wide inductance range with low DC resistance and high current handling capabilities
- Magnetic shield construction allows for use in high-density mounting configurations
- Flat bottom surface ensures secure, reliable mounting
- Dimensions: 7.0 x 7.0 x 3.2 mm
- Operating temperature range of -40°C to +105°C

### APPLICATION EXAMPLES

- Thin-screen TVs
- AV equipment
- Gaming equipment
- Other electrical devices

### SLF7032-KIT Contents

TDK Part Number	Description	Quantity
SLF7032T-3R3M1R9-2PF	3.3μH ±20%, 1.9A, 27.6mΩ	3 pcs
SLF7032T-4R7M1R7-2PF	4.7μH ±20%, 1.7A, 36mΩ	3 pcs
SLF7032T-6R8M1R6-2PF	6.8μH ±20%, 1.6A, 49.2mΩ	3 pcs
SLF7032T-100M1R4-2PF	10μH ±20%, 1.4A, 63.6mΩ	3 pcs
SLF7032T-150M1R1-2PF	15μH ±20%, 1.1A, 90mΩ	3 pcs
SLF7032T-220MR96-2PF	22μH ±20%, 0.96A, 132mΩ	3 pcs
SLF7032T-330MR75-2PF	33μH ±20%, 0.75A, 192mΩ	3 pcs
SLF7032T-470MR67-2PF	47μH ±20%, 0.67A, 288mΩ	3 pcs
SLF7032T-680MR59-2PF	68μH ±20%, 0.59A, 372mΩ	3 pcs
SLF7032T-101MR45-2PF	100μH ±20%, 0.45A, 540mΩ	3 pcs
SLF7032T-151MR37-2PF	150μH ±20%, 0.37A, 780mΩ	3 pcs
SLF7032T-221MR29-2PF	220μH ±20%, 0.29A, 1.26Ω	3 pcs
SLF7032T-331MR22-2PF	330μH ±20%, 0.22A, 2.004Ω	3 pcs
SLF7032T-471MR20-2PF	470μH ±20%, 0.2A, 2.46Ω	3 pcs
SLF7032T-681MR16-2PF	680μH ±20%, 0.16A, 3.78Ω	3 pcs
SLF7032T-102MR13-2PF	1mH ±20%, 0.13A, 5.736Ω	3 pcs

### PRODUCT DIMENSIONS

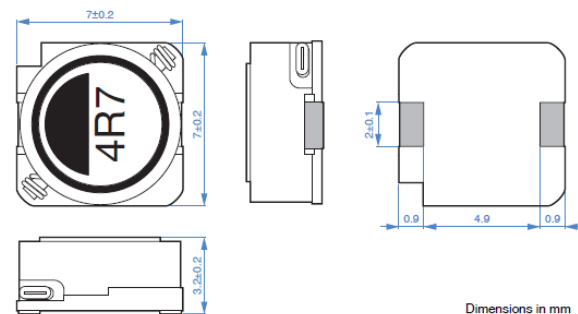

### DESIGN RESOURCES

- [SLF7032 Datasheet](#)
- [Selection Guide - Inductors for Power Circuits \(Commercial Grade\)](#)
- [Application Note - How to Use Power Inductors](#)